

User Manual
Model T201
Chemiluminescence NH₃ Analyzer
with NumaView™ software

© TELEDYNE API (TAPI)
9970 CARROLL CANYON ROAD
SAN DIEGO, CALIFORNIA 92131-1106
USA

Toll-free Phone: +1 800-324-5190
Phone: +1 858-657-9800
Fax: +1 858-657-9816
Email: api-sales@teledyne.com
Website: <http://www.teledyne-api.com/>



NOTICE OF COPYRIGHT

© 2021 Teledyne API (TAPI). All rights reserved.

TRADEMARKS

All trademarks, registered trademarks, brand names or product names appearing in this document are the property of their respective owners and are used herein for identification purposes only.

SAFETY MESSAGES

Important safety messages are provided throughout this manual for the purpose of avoiding personal injury or instrument damage. Please read these messages carefully. Each safety message is associated with a safety alert symbol and is placed throughout this manual; the safety symbols are also located inside the instrument. It is imperative that you pay close attention to these messages, the descriptions of which are as follows:



WARNING: Electrical Shock Hazard



HAZARD: Strong oxidizer



GENERAL WARNING/CAUTION: Read the accompanying message for specific information.



CAUTION: Hot Surface Warning



Do Not Touch: Touching some parts of the instrument without protection or proper tools could result in damage to the part(s) and/or the instrument.



Technician Symbol: All operations marked with this symbol are to be performed by qualified maintenance personnel only.



Electrical Ground: This symbol inside the instrument marks the central safety grounding point for the instrument.

CAUTION

This product should only be installed, commissioned, and used strictly for the purpose and in the manner described in this manual. If you improperly install, commission, or use this instrument in any manner other than as instructed in this manual or by our Technical Support team, unpredictable behavior could ensue with possible hazardous consequences.

Such risks, whether during installation and commission or caused by improper installation/commissioning/use, and their possible hazardous outcomes include but are not limited to:



RISK	HAZARD
Liquid or dust/debris ingress	Electrical shock hazard
Improper or worn power cable	Electrical shock or fire hazard
Excessive pressure from improper gas bottle connections	Explosion and projectile hazard
Sampling combustible gas(es)	Explosion and fire hazard
Improper lift & carry techniques	Personal injury

Note that the safety of a system that may incorporate this product is the end user's responsibility.

For Technical Assistance regarding the use and maintenance of this instrument or any other Teledyne API product, contact Teledyne API's Technical Support Department:

Telephone: +1 800-324-5190
 Email: api-techsupport@teledyne.com

or access any of the service options on our website at <http://www.teledyne-api.com/>



CONSIGNES DE SÉCURITÉ

Des consignes de sécurité importantes sont fournies tout au long du présent manuel dans le but d'éviter des blessures corporelles ou d'endommager les instruments. Veuillez lire attentivement ces consignes. Chaque consigne de sécurité est représentée par un pictogramme d'alerte de sécurité; ces pictogrammes se retrouvent dans ce manuel et à l'intérieur des instruments. Les symboles correspondent aux consignes suivantes :



AVERTISSEMENT : Risque de choc électrique



DANGER : Oxydant puissant



AVERTISSEMENT GÉNÉRAL / MISE EN GARDE : Lire la consigne complémentaire pour des renseignements spécifiques



MISE EN GARDE : Surface chaude



Ne pas toucher : Toucher à certaines parties de l'instrument sans protection ou sans les outils appropriés pourrait entraîner des dommages aux pièces ou à l'instrument.



Pictogramme « technicien » : Toutes les opérations portant ce symbole doivent être effectuées uniquement par du personnel de maintenance qualifié.



Mise à la terre : Ce symbole à l'intérieur de l'instrument détermine le point central de la mise à la terre sécuritaire de l'instrument.

MISE EN GARDE



Cet instrument doit être utilisé aux fins décrites et de la manière décrite dans ce manuel. Si vous utilisez cet instrument d'une autre manière que celle pour laquelle il a été prévu, l'instrument pourrait se comporter de façon imprévisible et entraîner des conséquences dangereuses.

NE JAMAIS utiliser des gaz combustibles avec ce produit!

MISE EN GARDE

Ce produit ne doit être installé, mis en service et utilisé qu'aux fins et de la manière décrites dans le présent manuel. Si vous installez, mettez en service ou utilisez cet instrument de manière incorrecte autre que celle indiquée dans ce manuel ou sous la direction de notre équipe de soutien technique, un comportement imprévisible pourrait entraîner des conséquences potentiellement dangereuses.

Ce qui suit est une liste, non exhaustive, des risques et résultats dangereux possibles associés avec une mauvaise utilisation, une mise en service incorrecte, ou causés mauvaise commission.



RISQUE	DANGER
Pénétration de liquide ou de poussière/débris	Risque de choc électrique
Câble d'alimentation incorrect, endommagés ou usé	Choc électrique ou risque d'incendie
Pression excessive due à des connexions de bouteilles de gaz incorrectes	Risque d'explosion et d'émission de projectile
Échantillonnage de gaz combustibles	Risque d'explosion et d'incendie
Techniques de manutention, soulèvement et de transport inappropriées	Blessure corporelle

Notez que la sécurité d'un système qui peut incorporer ce produit est la responsabilité de l'utilisateur final.

WARRANTY

WARRANTY POLICY (02024J)

Teledyne API (TAPI), a business unit of Teledyne Instruments, Inc., provides that: Prior to shipment, TAPI equipment is thoroughly inspected and tested. Should equipment failure occur, TAPI assures its customers that prompt service and support will be available. (For the instrument-specific warranty period, please refer to the “Limited Warranty” section in the Terms and Conditions of Sale on our website at www.teledyne-api.com).

COVERAGE

After the warranty period and throughout the equipment lifetime, TAPI stands ready to provide on-site or in-plant service at reasonable rates similar to those of other manufacturers in the industry. All maintenance and the first level of field troubleshooting are to be performed by the customer.

NON-TAPI MANUFACTURED EQUIPMENT

Equipment provided but not manufactured by TAPI is warranted and will be repaired to the extent and according to the current terms and conditions of the respective equipment manufacturer’s warranty.

PRODUCT RETURN

All units or components returned to Teledyne API should be properly packed for handling and returned freight prepaid to the nearest designated Service Center. After the repair, the equipment will be returned, freight prepaid.

The complete Terms and Conditions of Sale can be reviewed at our website..

CAUTION – Avoid Warranty Invalidation



Failure to comply with proper anti-Electro-Static Discharge (ESD) handling and packing instructions and Return Merchandise Authorization (RMA) procedures when returning parts for repair or calibration may void your warranty. For anti-ESD handling and packing instructions please refer to the manual, Fundamentals of ESD, PN 04786, in its “Packing Components for Return to Teledyne API’s Customer Service” section. The manual can be downloaded from our website at <http://www.teledyne-api.com>. RMA procedures can also be found on our website.

ABOUT THIS MANUAL

This manual includes MODBUS Registers in Appendix A and an interconnect diagram in Appendix B.

Support manuals, such as electrostatic discharge (ESD) prevention, are available on the TAPI website <http://www.teledyne-api.com>.

Note

We recommend that all users read this manual in its entirety before operating the instrument.

CONVENTIONS USED

In addition to the safety symbols as presented in the *Safety Messages* page, this manual provides *special notices* related to the careful and effective use of the instrument and related, pertinent information.

ATTENTION

COULD DAMAGE INSTRUMENT AND VOID WARRANTY
This special notice provides information to avoid damage to your instrument and possibly invalidate the warranty.

Important

IMPACT ON READINGS OR DATA
Provides information about that which could either affect accuracy of instrument readings or cause loss of data.

Note

Provides information pertinent to the proper care, operation or maintenance of the instrument or its parts.

TABLE OF CONTENTS

Safety Messages.....	ii
Warranty.....	vi
Table of Contents.....	viii
List of Figures.....	xiii
List of Tables.....	xiv
1. INTRODUCTION, SPECIFICATIONS, APPROVALS, & COMPLIANCE.....	17
1.1. Specifications.....	17
1.2. Compliance and Certifications.....	18
2. GETTING STARTED.....	19
2.1. Unpacking.....	19
2.1.1. Ventilation Clearance.....	20
2.2. Instrument Layout.....	21
2.2.1. Front Panel.....	21
2.2.2. Rear Panel.....	22
2.2.3. Internal Chassis.....	25
2.3. Connections and Startup.....	27
2.3.1. Electrical Connections.....	27
2.3.1.1. Connecting Power.....	27
2.3.1.2. Connecting Analog Outputs.....	28
2.3.1.3. Current Loop Analog Outputs (Option 41) Setup.....	29
2.3.1.4. Connecting the Status Outputs (Digital Outputs).....	30
2.3.1.5. Connecting the Control Inputs (Digital Inputs).....	31
2.3.1.6. Connecting the Analyzer to the External Converter.....	32
2.3.1.7. Concentration Alarm Relay (Option 61).....	32
2.3.1.8. Connecting Communications Interfaces.....	33
2.3.2. Pneumatic Connections.....	39
2.3.2.1. Special Considerations for Tubing and Fittings.....	39
2.3.2.2. Sample Filtration.....	40
2.3.2.3. Pneumatic Connections T201, 501, External Calibrator.....	40
2.3.2.4. Basic Connections from Calibrator.....	42
2.3.3. Pneumatic Flow Diagrams.....	43
2.3.4. Startup, Functional Checks and Calibration.....	45
2.3.4.1. Startup.....	46
2.3.4.2. Alerts: Warnings and Other Messages.....	47
2.3.4.3. Functional Checks.....	48
2.3.4.4. Calibration.....	48
2.4. Menu Overview.....	49
2.4.1. Home Page.....	50
2.4.2. Dashboard.....	52
2.4.3. Alerts.....	53
2.4.4. Calibration.....	54
2.4.5. Utilities.....	55
2.4.6. Setup.....	55
2.5. Setup Menu: Features/Functions Configuration.....	56
2.5.1. Setup>Data Logging (Data Acquisition System, DAS).....	56
2.5.1.1. Configuring Trigger Types: Periodic.....	58
2.5.1.2. Configuring Trigger Types: Conditional.....	59
2.5.1.3. Downloading DAS (Data Acquisition System) Data.....	59
2.5.2. Setup>Events.....	60
2.5.2.1. Editing or Deleting Events.....	62
2.5.2.2. Using Events as Triggers for Data Logging.....	63
2.5.3. Setup>Dashboard.....	63

2.5.4. Setup>AutoCal (with Valve Option)	64
2.5.5. Setup>Vars	64
2.5.6. Setup>Homescreen	65
2.5.7. Setup>Digital Outputs	66
2.5.8. Setup>Analog Outputs	67
2.5.8.1. Manual Calibration of Voltage Range Analog Outputs	69
2.5.8.2. Manual Adjustment of Current Range Analog Outputs	70
2.5.9. Setup>Instrument	71
2.5.10. Setup>Comm (Communications)	72
2.5.10.1. COM1/COM2	72
2.5.10.2. TCP Port1	73
2.5.10.3. TCP Port2	73
2.5.10.4. TCP Port3	73
2.5.10.5. Network Settings	73
2.6. Transferring Configuration to Other Instruments	75
3. COMMUNICATIONS AND REMOTE OPERATION	76
3.1. Data Terminal/Communication Equipment (DTE DCE)	76
3.2. Serial Communication	76
3.2.1. Serial Communication: RS-232	77
3.2.2. Serial Communication: RS-485 (Option)	77
3.3. Ethernet	77
3.4. Numaview™ Remote	78
3.5. Communications Protocols	78
3.5.1. MODBUS	78
3.5.1.1. MODBUS Com Port Configuration	78
3.5.2. Hessen	80
3.5.2.1. Hessen Com Port Configuration	80
3.5.2.2. Hessen Settings Configuration	81
3.5.2.3. Hessen Gas List Configuration	83
4. CALIBRATION	84
4.1. Important Precalibration Information	84
4.1.1. Leak Check	84
4.1.2. Calibration Requirements	84
4.1.3. Zero Air	85
4.1.4. Calibration (Span) Gas	85
4.1.5. Span Gas for Multipoint Calibration	86
4.1.6. Physical Range Measurements	86
4.1.7. Interferents	87
4.1.8. Data Recording Devices	87
4.1.9. Conversion Efficiency (CE)	87
4.2. Calibration Procedures	88
4.2.1. Calibration and Check Procedures for Basic Configuration	89
4.2.1.1. Zero Calibration Check and Actual Calibration	89
4.2.1.2. NO Span Calibration Check and Actual Calibration	89
4.2.1.3. NH ₃ (Ammonia) Span Calibration Check and/or Actual Calibration, and NH ₃ Converter Efficiency (CE) Check	90
4.2.2. Calibration and Check Procedures with Valve Options Installed	92
4.2.2.1. Use of Zero/Span Valve with Remote Contact Closure	92
4.3. Automatic Zero/Span Cal/Check (Auto Cal)	93
4.4. Calibration Quality Analysis	95
4.5. NO ₂ Conversion Efficiency (CE) Check	96
4.5.1. NO ₂ CE Check Procedures	97
4.5.2. NO ₂ Moly CE Check Data Sheet	98
5. MAINTENANCE AND SERVICE	99
5.1. Maintenance Schedule	99

5.2. Predictive Diagnostics	101
5.3. Operational Health Checks	102
5.4. Software/Firmware Updates.....	103
5.4.1. Remote Updates	103
5.4.2. Manual Reload/Update Procedures.....	103
5.5. Time Zone Changes.....	105
5.6. Hardware Maintenance Procedures	106
5.6.1. Checking the AutoZero Flow.....	106
5.6.2. Maintaining the 501 Converter.....	107
5.6.2.1. Replacing the Catalytic Cartridge	109
5.6.2.2. Replacing the Thermocouple.....	110
5.6.3. Changing the O ₃ Dryer Particulate Filter.....	112
5.6.4. Changing the Ozone Cleanser Chemical	113
5.6.5. Maintaining the External Sample Pump (Pump Pack).....	116
5.6.5.1. Rebuilding the Pump	116
5.6.5.2. Replacing the Scrubber	116
5.6.6. Changing or Cleaning the NO ₂ Converter.....	117
5.6.7. Cleaning the Reaction Cell	119
5.6.8. Servicing Critical Flow Orifices	120
5.6.9. Checking for Light Leaks	122
5.6.10. Checking for Pneumatic Leaks	123
5.6.10.1. Simple Vacuum Leak and Pump Check	123
5.6.10.2. Detailed Pressure Leak Check	123
5.6.10.3. Performing Flow Checks/Calibrations.....	124
5.7. Service and Troubleshooting	126
5.7.1. Fault Diagnosis with Alerts.....	127
5.7.2. Fault Diagnosis With Dashboard Functions.....	130
5.7.3. Using the Diagnostic Signal I/O Functions	131
5.7.4. Using the Analog Output Channels.....	132
5.7.5. Using the Internal Electronic Status LEDs	133
5.7.5.1. CPU Status Indicator	133
5.7.5.2. Relay PCA Watchdog and Status LEDs.....	134
5.7.6. Flow Problems	135
5.7.6.1. Sample Flow is Zero or Low	135
5.7.6.2. Ozone Flow is Zero or Low.....	137
5.7.6.3. SAMPLE FLOW TOO High.....	138
5.7.6.4. Sample Flow is Zero or Low but Analyzer Reports Correct Flow.....	138
5.7.7. Calibration Problems.....	139
5.7.7.1. Negative Concentrations	139
5.7.7.2. Absence of Analyzer Response to Sample Gas.....	140
5.7.7.3. Unstable Zero and Span.....	140
5.7.7.4. Inability to Span - Deactivated SPAN Button.....	141
5.7.7.5. Inability to Zero - Deactivated ZERO Button	141
5.7.7.6. Non-Linear Response.....	141
5.7.7.7. Discrepancy Between Analog Output and Display	142
5.7.7.8. Discrepancy Between NO and NO _x Slopes	143
5.7.8. Other Performance Problems	143
5.7.8.1. Excessive Noise.....	143
5.7.8.2. Slow Response.....	143
5.7.8.3. Auto Zero Warnings.....	144
5.7.9. Subsystem Check for Troubleshooting.....	145
5.7.9.1. AC Main Power	145
5.7.9.2. DC Power Supply.....	146
5.7.9.3. I ² C Bus	147
5.7.9.4. LCD/Display Module	147
5.7.9.5. Relay PCA	148

5.7.9.6. Motherboard.....	148
5.7.9.7. Pressure / Flow Sensor Assembly.....	150
5.7.9.8. CPU	151
5.7.9.9. RS-232 Communications.....	152
5.7.9.10. Converters (NO ₂ → NO and TN _x → NO)	152
5.7.9.11. Photomultiplier Tube (PMT) Sensor Module.....	154
5.7.9.12. PMT Preamplifier Board.....	155
5.7.9.13. High Voltage Power Supply (HVPS).....	155
5.7.9.14. PMT Temperature Control PCA.....	156
5.7.9.15. O ₃ Generator.....	156
5.7.9.16. Temperature Sensor	157
5.7.10. Service Procedures.....	158
5.7.10.1. Disk-On-Module Replacement Procedure	158
5.7.10.2. O ₃ Generator Replacement	159
5.7.10.3. Sample and Ozone Dryer Replacement	160
5.7.10.4. PMT Sensor Hardware Calibration	160
5.7.10.5. PMT, HVPS or TEC Replacement.....	162
5.7.10.6. Removing / Replacing the Relay PCA from the Instrument.....	165
5.8. Frequently Asked Questions.....	166
5.9. Technical Assistance	167
6. PRINCIPLES OF OPERATION	168
6.1. Measurement Principles.....	168
6.1.1. Chemiluminescence Creation in the Reaction Cell.....	169
6.1.2. Chemiluminescence Detection in the Reaction Cell	170
6.1.2.1. The Photo Multiplier Tube (PMT).....	170
6.1.2.2. Optical Filter.....	171
6.1.3. NO _x and NO ₂ Determination	172
6.1.4. Minimizing PMT Drift: Auto Zero	173
6.1.5. Purging the Reaction Cell	173
6.1.6. Measurement Interferences	173
6.1.6.1. Direct Interference	174
6.1.6.2. Third Body Quenching	174
6.1.6.3. Light Leaks.....	174
6.1.6.4. Reaction Cell Temperature Control	175
6.2. Pneumatic Operation	176
6.2.1. Sample Gas Flow.....	176
6.2.1.1. Vacuum Manifold	177
6.2.1.2. Sample Gas Flow Valves and Routing	178
6.2.2. Flow Rate Control - Critical Flow Orifices	178
6.2.2.1. Critical Flow Orifice	179
6.2.2.2. Locations and Descriptions of Critical Flow Orifices.....	180
6.2.3. Ozone Gas Generation and Air Flow	181
6.2.3.1. The O ₃ Generator	182
6.2.3.2. Ozone Generator Dry Air Supply	182
6.2.3.3. Ozone Supply Air Filter.....	184
6.2.3.4. Ozone Destruct.....	184
6.2.4. Pneumatic Sensors	185
6.2.4.1. Sample Pressure Sensor.....	185
6.2.4.2. Vacuum Pressure Sensor.....	185
6.2.4.3. Sample Gas Flow Calculation.....	185
6.2.4.4. O ₃ Supply Air Flow Sensor	186
6.3. Electronic Operation.....	186
6.3.1. CPU.....	188
6.3.2. Motherboard.....	189
6.3.2.1. A to D Conversion.....	189

6.3.2.2. Sensor Inputs.....	189
6.3.2.3. Thermistor Interface.....	190
6.3.2.4. Analog Outputs.....	190
6.3.2.5. External Digital I/O.....	190
6.3.2.6. Internal Digital I/O.....	190
6.3.2.7. I ² C Data Bus.....	191
6.3.2.8. Power-Up Circuit.....	191
6.3.3. Relay PCA.....	191
6.3.3.1. Status LED's.....	193
6.3.3.2. Watchdog Circuitry.....	193
6.3.3.3. Valve Control.....	193
6.3.3.4. Heater Control.....	193
6.3.3.5. Thermocouple Inputs and Configuration Jumper (JP5).....	194
6.4. Sensor Module.....	196
6.5. Photo Multiplier Tube (PMT).....	196
6.5.1. PMT Preamplifier.....	197
6.5.2. PMT Cooling System.....	199
6.5.2.1. TEC Control Board.....	200
6.6. Pneumatic Sensor Board.....	200
6.7. Power Supply/Circuit Breaker.....	201
6.7.1. AC Power Configuration.....	202
6.7.1.1. AC Configuration – Standard Heaters (JP2).....	203
6.8. Front Panel Touchscreen/Display Interface.....	204
6.8.1. LVDS Transmitter Board.....	205
6.8.2. Front Panel Touchscreen/Display Interface PCA.....	205
6.9. Software Operation.....	205
6.9.1. Adaptive Filter.....	206
6.9.2. Temperature/Pressure Compensation (TPC).....	206
6.9.3. Calibration - Slope and Offset.....	207
Glossary.....	208

LIST OF FIGURES

Figure 2-1. Front Panel Layout	21
Figure 2-2. Rear Panel Layout, Base Unit (options include additional pneumatic ports)	22
Figure 2-3. Model 501 Rear Panel	24
Figure 2-4. Model T201 Internal Chassis Layout	25
Figure 2-5. Model 501 Internal Chassis Layout	26
Figure 2-6. Analog Output Connector	28
Figure 2-7. Current Loop Option Installed on the Motherboard	29
Figure 2-8. Status Output Connector for Digital Outputs	30
Figure 2-9. Energizing the Control Inputs	31
Figure 2-10. Concentration Alarm Relay	32
Figure 2-11. Rear Panel Connector Pin-Outs for RS-232 Mode	34
Figure 2-12. Default Pin Assignments for CPU COM Port Connector (RS-232)	35
Figure 2-13. Jumper and Cables for Multidrop Mode	37
Figure 2-14. RS-232 Multidrop PCA Option Host/Analyzer Interconnect Diagram	38
Figure 2-15. Pneumatic Connections (bottom to top) T201>501>External Calibrator Option (ECO).....	41
Figure 2-16. Gas Line Connections from Calibrator – Basic Configuration	42
Figure 2-17. T201 and 501 NH ₃ Pneumatic Flow	43
Figure 2-18. T201 and 501 NH ₃ with Zero/Span Valves Option Pneumatic Flow	44
Figure 2-19. Status Screens at Startup.....	46
Figure 2-20. Home Page Example.....	46
Figure 2-21. Alerts Page	47
Figure 2-22. Sample Dashboard Page	48
Figure 2-23. User Interface Orientation	50
Figure 2-24. Concentration and Stability Graph (top) and Meter Graph (bottom)	51
Figure 2-25. Dashboard Page.....	52
Figure 2-26. Navigating to the Active Alerts Page	53
Figure 2-27. Active Alerts Cleared	54
Figure 2-28. Utilities>Alerts Log of Active and Past Alerts and Events	54
Figure 2-29. Datalog Configuration, New Log Page	56
Figure 2-30. Datalog Configuration, Existing Log	56
Figure 2-31. Creating a New Data Log	57
Figure 2-32. Datalog Periodic Trigger Configuration	58
Figure 2-33. Datalog - Conditional Trigger Configuration	59
Figure 2-34. DAS Download Page.....	59
Figure 2-35. Events List	60
Figure 2-36. Event Configuration	61
Figure 2-37. Configured Event Sample.....	62
Figure 2-38. Edit or Delete an Event.....	62
Figure 2-39. Dashboard Display and Configuration.....	63
Figure 2-40. Homescreen Configuration.....	65
Figure 2-41. Digital Outputs Setup.....	66
Figure 2-42. Analog Output Configuration Example	67
Figure 2-43. Analog Outputs Group Calibration Screen	68
Figure 2-44. Analog Outputs Manual Calibration Screen (AOUT2 Example).....	68
Figure 2-45. Setup for Checking / Calibrating DCV Analog Output Signal Levels	69
Figure 2-46. Setup for Checking / Calibration Current Output Signal Levels	70
Figure 2-47. Alternative Setup Using 250Ω Resistor for Checking Current Output Signal Levels	71
Figure 2-48. Communications Configuration, Network Settings	73
Figure 2-49. Configuration Transfer.....	75
Figure 3-1. MODBUS via Ethernet.....	78
Figure 3-2. MODBUS via Serial Communication (example).....	79
Figure 3-3. Serial Communication, Setting Hessen Protocol.....	80
Figure 3-4. Hessen Gas List Configuration.....	83
Figure 4-1. Multi-Point Calibration Page	89

Figure 4-2. Zero and Span Calibration Screens	92
Figure 4-3. Auto Cal Page.....	93
Figure 5-1: Report Generation Page.....	102
Figure 5-2. Remote Update Page	103
Figure 5-3. Manual Update Page (and other utilities).....	103
Figure 5-4. Time Zone Change Requirements	105
Figure 5-5. Model 501 Chassis Internal Layout	108
Figure 5-6. Model 501 Converter, Exploded View	108
Figure 5-7. Catalytic Cartridge	109
Figure 5-8. Thermocouple Location	110
Figure 5-9. Thermocouple and Wiring Location.....	111
Figure 5-10. Particle Filter on O ₃ Supply Air Dryer	113
Figure 5-11. Ozone Cleanser Assembly	114
Figure 5-12. NO ₂ Converter Assembly.....	118
Figure 5-13. Reaction Cell Assembly.....	119
Figure 5-14. Critical Flow Orifice Assembly	121
Figure 5-15. Flow Calibration Menu.....	125
Figure 5-16. Ozone Flow Calibration Menu	125
Figure 5-17. CPU Status Indicator	133
Figure 5-18. Relay PCA Status LEDES Used for Troubleshooting.....	134
Figure 5-19. Location of DC Power Test Points on Relay PCA.....	146
Figure 5-20. Typical Set Up of Status Output Test.....	149
Figure 5-21. Pressure / Flow Sensor Assembly.....	150
Figure 5-22. Pre-Amplifier Board Layout	161
Figure 5-23. Sensor Assembly.....	163
Figure 5-24. Relay PCA with AC Relay Retainer In Place.....	165
Figure 5-25. Relay PCA Mounting Screw Locations.....	165
Figure 6-1. Reaction Cell with PMT Tube and Optical Filter.....	171
Figure 6-2. Sensitivity Spectrum	171
Figure 6-3. NO ₂ → NO Conversion	172
Figure 6-4. Vacuum Manifold, Standard Configuration.....	177
Figure 6-5. Flow Control Assembly & Critical Flow Orifice	179
Figure 6-6. Location of Flow Control Assemblies & Critical Flow Orifices	180
Figure 6-7. Ozone Generator Principle	182
Figure 6-8. Semi-Permeable Membrane Drying Process	183
Figure 6-9. Sample Dryer.....	183
Figure 6-10. CPU Board.....	188
Figure 6-11. Relay PCA Layout (P/N 045230100).....	192
Figure 6-12. Relay PCA P/N 045230100 with AC Relay Retainer in Place.....	193
Figure 6-13. Thermocouple Configuration Jumper (JP5) Pin-Outs	195
Figure 6-14. Basic PMT Design	196
Figure 6-15. PMT Preamp Block Diagram	198
Figure 6-16. Typical Thermo-Electric Cooler	199
Figure 6-17. PMT Cooling System Block Diagram	200
Figure 6-18. Location of AC power Configuration Jumpers.....	202
Figure 6-19. Typical Set Up of AC Heater Jumper Set (JP2)	203
Figure 6-20. Front Panel and Display Interface Block Diagram.....	204
Figure 6-21. Basic Software Operation.....	205

LIST OF TABLES

Table 1-1. Specifications.....	17
Table 2-1. Ventilation Clearance.....	20
Table 2-2. Rear Panel Description	23
Table 2-3. Analog Output Pin Assignments	28
Table 2-4. Status Output Pin Assignments	31

Table 2-5. Control Input Pin Assignments	32
Table 2-6. Menu Overview	49
Table 2-7. Utilities Submenu Descriptions	55
Table 2-8. List of Variables with Descriptions	64
Table 2-9. Analog Output Voltage/Current Range	68
Table 2-10. Voltage Tolerances	69
Table 2-11. Current Loop Output Check	71
Table 2-12. Setup>Instrument Menu	71
Table 2-13. COM1/COM2 Configuration	72
Table 2-14. LAN/Ethernet Configuration Properties	74
Table 3-1. Ethernet Status Indicators	77
Table 3-2. Teledyne API's Hessen Protocol Response Modes	81
Table 3-3. Hessen Status Flags and Default Bit Assignments	82
Table 3-4. Hessen Gas List Definitions	83
Table 4-1. AUTO CAL States	94
Table 4-2. Auto Cal Setup Combinations	94
Table 4-3. Auto Cal Programming Sequence Execution	95
Table 4-4. Calibration Data Quality Evaluation	96
Table 5-1. Maintenance Schedule	100
Table 5-2. Predictive Uses for Dashboard Functions	101
Table 5-3. Flow Check	106
Table 5-4. Warning Alerts, Fault Conditions and Possible Causes	127
Table 5-5. Dashboard Functions - Indicated Failures	131
Table 5-6. Analog Outputs as Diagnostic Tools	132
Table 5-7. Relay PCA Watchdog and Status LED Descriptions and Failure Indications	134
Table 5-8. DC Power Test Point and Wiring Color Codes	146
Table 5-9. DC Power Supply Acceptable Levels	147
Table 5-10. Relay PCA Control Devices	148
Table 5-11. Control Input Pin Assignments and Corresponding Signal I/O Functions	149
Table 6-1. Valve Cycle Phases	178
Table 6-2. Thermocouple Configuration Jumper (JP5) Pin-Outs	195
Table 6-3. Power Configuration for Standard AC Heaters (JP2)	203



T201

This page intentionally left blank.

1. INTRODUCTION, SPECIFICATIONS, APPROVALS, & COMPLIANCE

Teledyne API's Model T201 NH₃ (Ammonia) Analyzer uses chemiluminescence detection (see Principles of Operation, Section 6, this manual) combined with an external thermal converter, to measure trace ammonia (NH₃), nitric oxide (NO), nitrogen dioxide (NO₂), total nitrogen oxides (NO_x), and TN_x (ammonia and total nitrogen oxides). Its impressive stability is achieved by use of an autozero valve, which measures and corrects for PMT drift.

Along with providing high accuracy and dependability, the T201 tracks operational parameters and issues warnings if they fall outside diagnostic limits, as well as stores easily retrievable data. Proprietary software allows configurable data acquisition capability that can be triggered conditionally or periodically, enabling operators to perform predictive diagnostics and enhanced data analysis by tracking parameter trends. Reports can be downloaded onto a USB flash drive or via the I/O ports. Operators can also view real-time graphing with one touch of the interface screen.

1.1. SPECIFICATIONS

Table 1-1. Specifications

PARAMETER	SPECIFICATION		
Min/Max Range	Min: 0-50 ppb Full Scale Max: 0-2,000 ppb Full Scale (selectable, independent NH ₃ , NO, NO ₂ , NO _x ranges supported)		
Measurement Units	ppb, ppm, µg/m ³ , mg/m ³ (selectable)		
Zero Noise ¹	< 0.5 ppb (RMS)		
Span Noise	< 1% of reading		
Lower Detectable Limit	< 1 ppb		
Zero Drift	< 0.5 ppb/24 hours (NO, NO _x)		
Span Drift	< 1% of Full Scale/24 hours		
Response Time *	< 340 seconds to 90%		
Linearity	1% of full scale		
Precision	0.5% of reading above 50 ppb		
Sample Flow Rate	1000 cc/min ± 10%		
AC Power	Rating	Typical Power Consumption	
	Analyzer	100-120 V~, 220-240 V~, 50/60 Hz, 3.0 A	125 W
	Converter	100-120 V~, 220-240 V~, 50/60 Hz, 3.0 A	480 W
Analog Output Ranges	10V, 5V, 1V, 0.1V (selectable) All Ranges with 5% Under/Over Range		
Analog Output Resolution	1 part in 4096 of selected full-scale voltage (12 bit)		
Recorder Offset	± 10%		



PARAMETER	SPECIFICATION
Standard I/O	1 Ethernet: 10/100Base-T 2 RS-232 (300 – 115,200 baud) 2 USB device ports 8 opto-isolated digital status outputs (7 defined, 1 spare) 6 opto-isolated digital control inputs (4 defined, 2 spare) 4 analog outputs
Optional I/O	1 USB com port 1 RS485 4 digital alarm outputs Multidrop RS232 3 4-20mA current outputs
Dimensions H x W x D	Analyzer: 7" x 17" x 23.5" (178mm x 432 mm x 597 mm) Converter: 7" x 17" x 23.5" (178 mm x 432 mm x 597 mm)
Weight	Analyzer: 43 lbs (20 kg) Converter: 22 lbs (10 kg)
Operating Temperature Range	15 - 40 °C
Humidity Range	0-95% RH non-condensing
Environmental Conditions	Installation Category (Over voltage Category) II Pollution Degree 2 Intended for Indoor Use Only at Altitudes ≤ 2000m

All specifications are based on constant conditions.

* Response Time includes consideration for pneumatics being conditioned with NH₃ overnight, and the gases (zero air to NH₃) are manually switched at the sample inlet at the rear of the 501.

1.2. COMPLIANCE AND CERTIFICATIONS

This product is CE compliant and adheres to the Low Voltage and ElectroMagnetic Compatibility directives.

For any other certifications, please refer to this product's specifications sheet on our website.

2. GETTING STARTED

This Section addresses unpacking, connecting, and initializing the instrument, getting an overview of the menu system, and setting up/configuring the functions.

2.1. UNPACKING



CAUTION - GENERAL SAFETY HAZARD

To avoid personal injury, always use two persons and proper lift and carry techniques to move/relocate the analyzer.

ATTENTION

COULD DAMAGE INSTRUMENT AND VOID WARRANTY

Printed Circuit Assemblies (PCAs) are sensitive to electro-static discharges too small to be felt by the human nervous system. Failure to use Electro-Static Discharge (ESD) protection when working with electronic assemblies will void the instrument warranty. Refer to the manual, Fundamentals of ESD, PN 04786, which can be downloaded from our website at <http://www.teledyne-api.com>.

ATTENTION

COULD DAMAGE INSTRUMENT AND VOID WARRANTY

Do not operate this instrument without first removing dust plugs from SAMPLE and EXHAUST ports on the rear panel.

Note

Teledyne API recommends that you store shipping containers and materials for future use if/when the instrument should be returned to the factory for repair and/or calibration service. See Warranty statement in this manual and Return Merchandise Authorization (RMA) on our Website at <http://www.teledyne-api.com>.

Verify that there is no apparent external shipping damage. If damage has occurred, please advise the shipper first, then Teledyne API.

Included with your instrument is a printed record of the final performance characterization performed on your instrument at the factory. This record, the Final Calibrated Test and Validation Data Sheet, is an important quality assurance and calibration record and should be placed in the quality records file for this instrument.



WARNING – ELECTRICAL SHOCK HAZARD

Never disconnect or reconnect PCAs, wiring harnesses or electronic subassemblies while instrument is under power.

With no power to the unit, carefully remove the top cover of the instrument and check for internal shipping damage by carrying out the following steps:

1. Carefully remove the top cover and check for internal shipping damage.
 - a. Remove the screws located on the instrument's sides.
 - b. Slide the cover backward until it clears the instrument's front bezel.
 - c. Lift the cover straight up.
2. Inspect the interior of the instrument to ensure all circuit boards and other components are intact and securely seated.
3. Check the connectors of the various internal wiring harnesses and pneumatic hoses to ensure they are firmly and securely seated.
4. Verify that all of the optional hardware ordered with the unit has been installed. These are listed on the paperwork accompanying the instrument.

2.1.1. VENTILATION CLEARANCE

Whether the instrument is set up on a bench or installed in a rack, be sure to leave sufficient ventilation clearance.

Table 2-1. Ventilation Clearance

AREA	MINIMUM REQUIRED CLEARANCE
Rear of instrument & Thermal Converter	10 cm / 4 in
Sides of instrument & Thermal Converter	2.5 cm / 1 in
Above and below instrument & Thermal Converter	2.5 cm / 1 in

2.2. INSTRUMENT LAYOUT

Instrument layout includes front panel, rear panel connectors, and the internal chassis layout.

2.2.1. FRONT PANEL

The front panel (Figure 2-1) includes two USB ports for peripheral device connections, which can be used with mouse and keyboard as alternatives to the touchscreen interface, or with flash drive for uploads/downloads (devices not included).

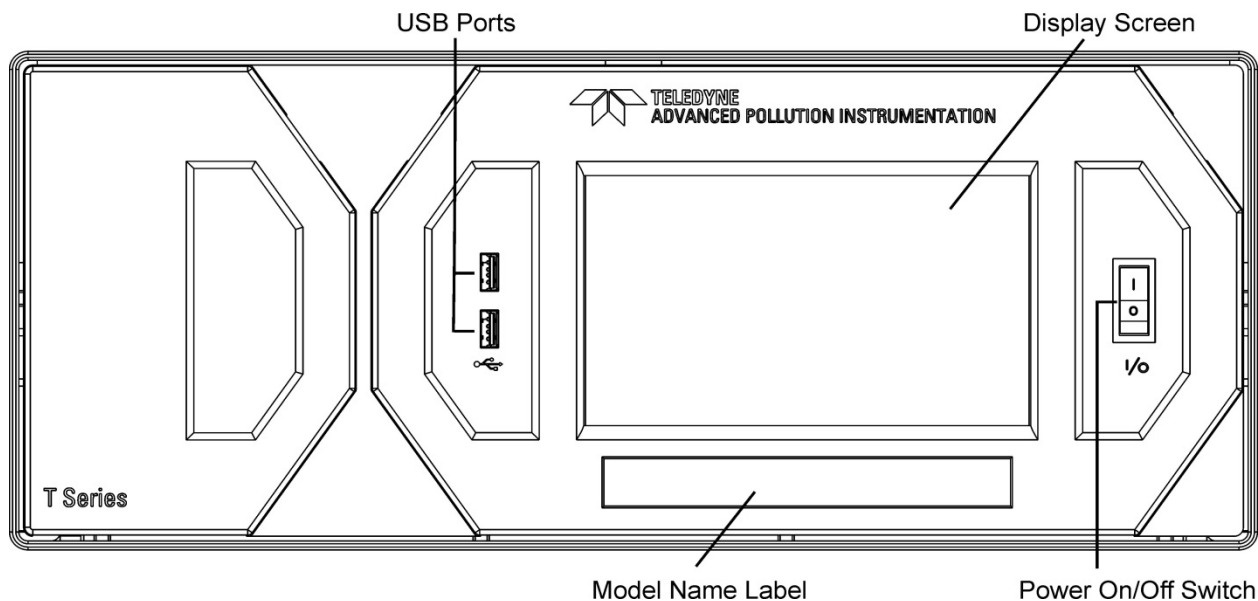

Figure 2-1. Front Panel Layout

2.2.2. REAR PANEL

Figure 2-2 shows the layout of the T201 Analyzer's rear panel.

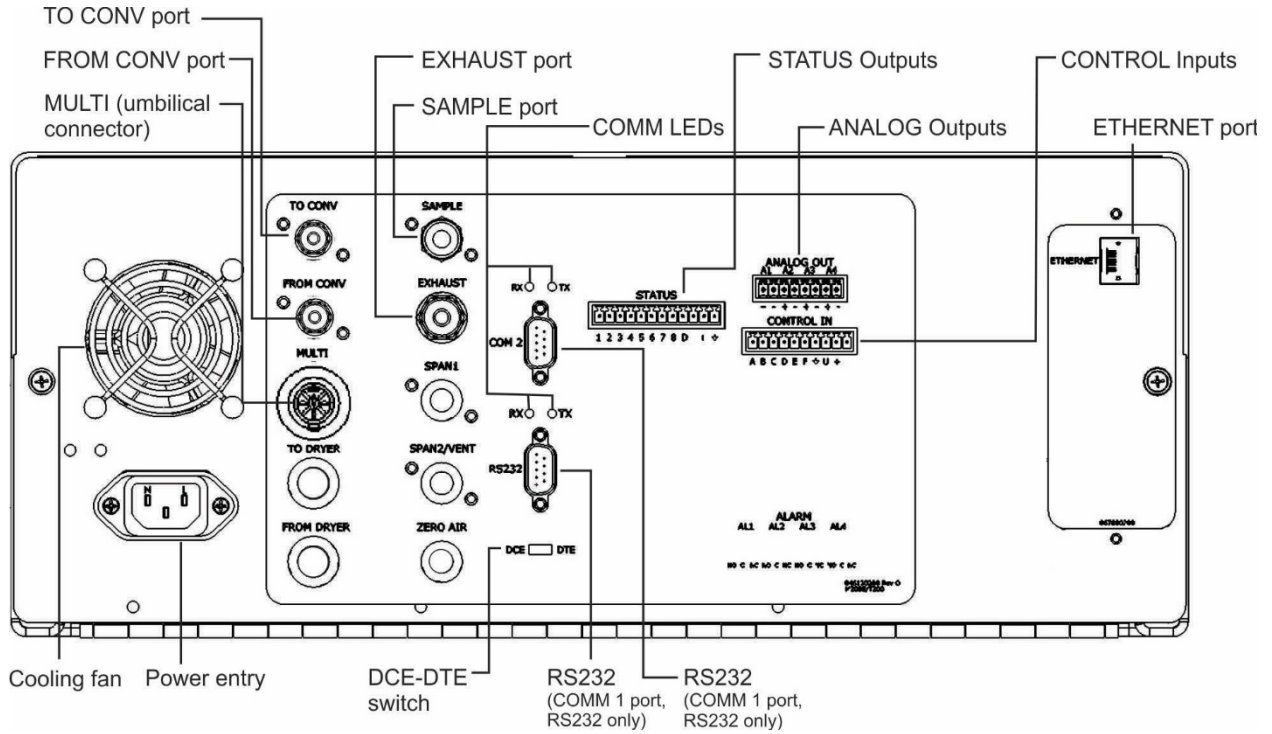



Figure 2-2. Rear Panel Layout, Base Unit (options include additional pneumatic ports)

Table 2-2. Rear Panel Description

COMPONENT	FUNCTION
cooling fan	Pulls ambient air into chassis through side vents and exhausts through rear.
 AC power connector	Connector for three-prong cord to apply AC power to the analyzer. CAUTION! The cord's power specifications (specs) MUST comply with the power specs on the analyzer's rear panel Model number label
Model/specs label	Identifies the analyzer model number and provides power specs
TO CONV	Connect a line to the converter's TN OUT port.
FROM CONV	Connect a line to the converter's TNX OUT port.
MULTI	With the Zero/Span option, run the umbilical cord from this connector to the converter's UMBILICAL connect
TO DRYER	(not used)
FROM DRYER	(not used)
SAMPLE	Connect a gas line from the source of sample gas here. Calibration gases can also enter here on units without zero/span/shutoff valve options installed.
EXHAUST	Connect an exhaust gas line to the external vacuum pump, not more than 10 meters long here that leads outside the shelter or immediate area surrounding the instrument. The line must be ¼" tubing or greater.
SPAN 1	On units with zero/span/shutoff valves option installed, connect a gas line to the source of calibrated span gas here.
SPAN2/VENT	On units with pressurized span valve option, used for venting.
ZERO AIR	Attach a gas line to the source of zero air here.
RX TX	LEDs indicate receive (RX) and transmit (TX) activity on the when blinking.
COM 2	Serial communications port for RS-232 or RS-485.
RS-232	Serial communications port for RS-232 only.
DCE DTE	Switch to select either data terminal equipment or data communication equipment during RS-232 communication.
STATUS	For outputs to devices such as Programmable Logic Controllers (PLCs).
ANALOG OUT	For voltage or current loop outputs to a strip chart recorder and/or a data logger.
CONTROL IN	For remotely activating the zero and span calibration modes.
ALARM	Option for concentration alarms and system warnings.
ETHERNET	Connector for network or Internet remote communication, using Ethernet cable
ANALOG IN	Option not available
Model Label	Includes voltage and frequency specifications

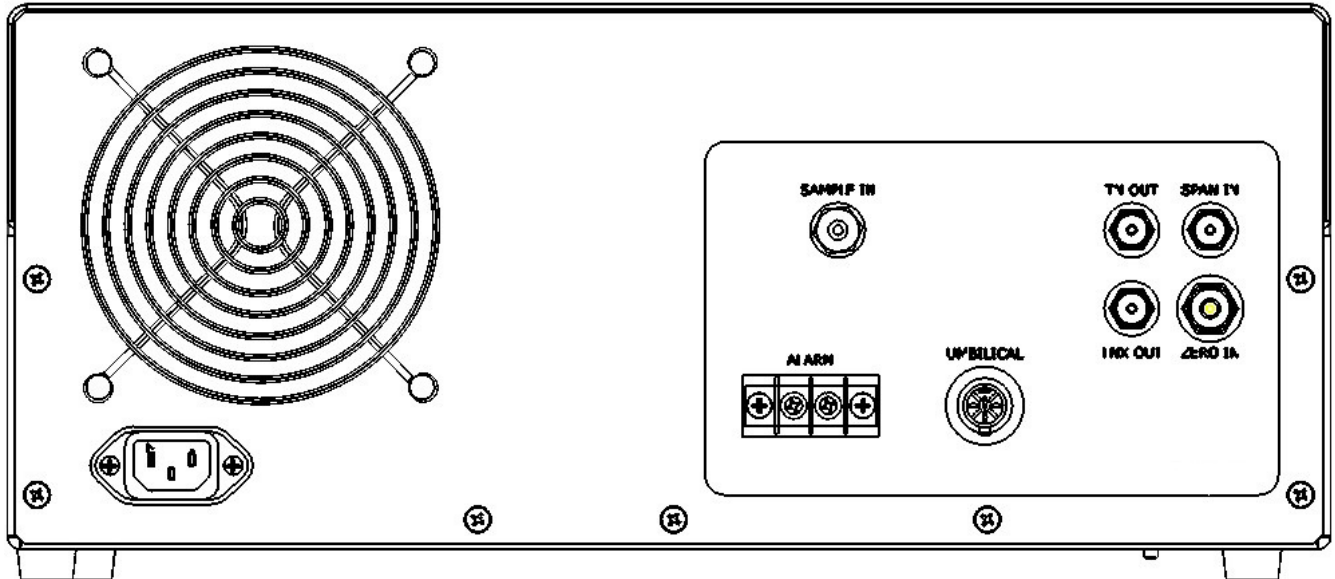

Figure 2-3. Model 501 Rear Panel

2.2.3. INTERNAL CHASSIS

Figure 2-4 and Figure 2-5 show the T201 and Model 501 internal layouts, respectively.

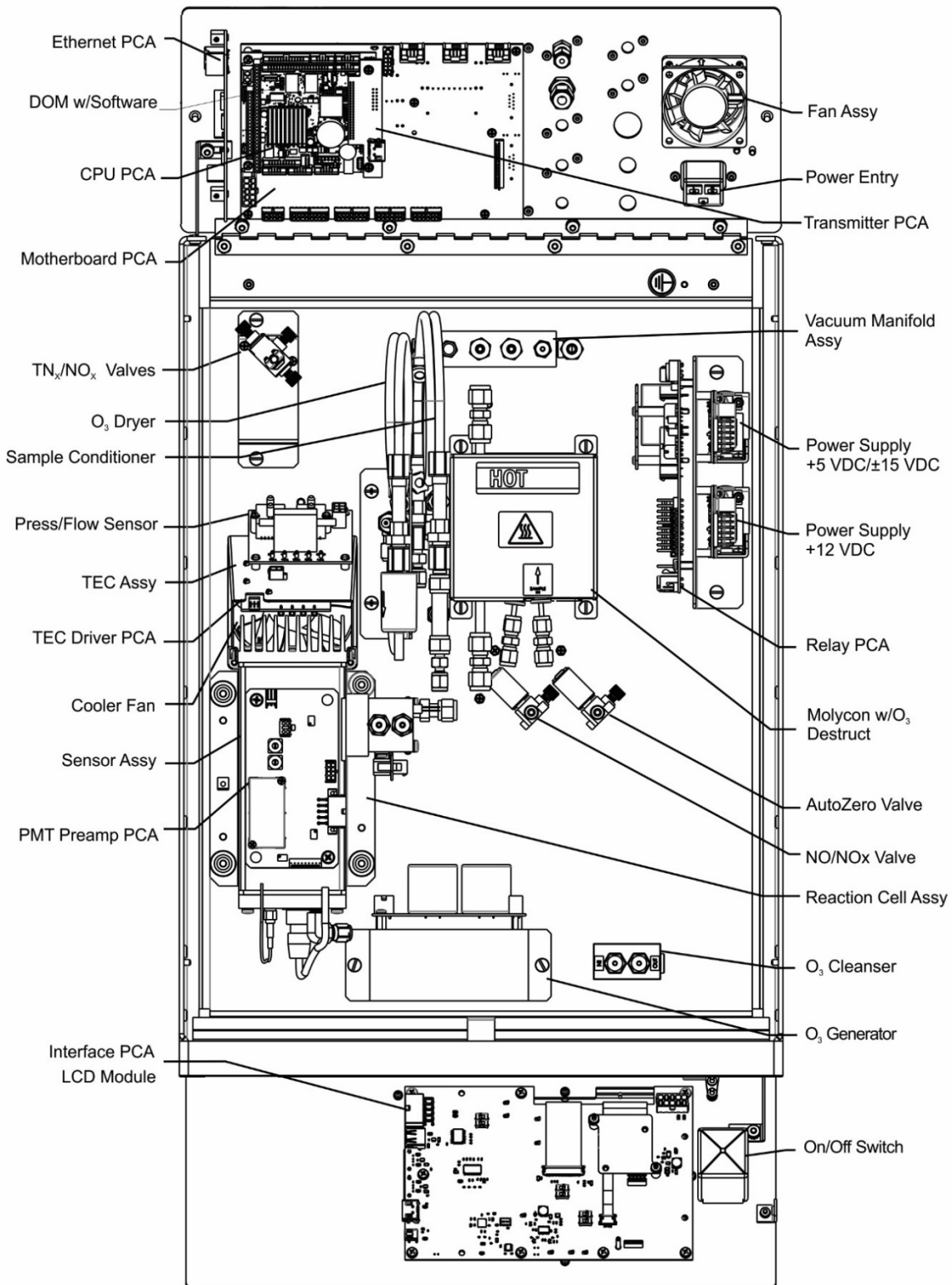

Figure 2-4. Model T201 Internal Chassis Layout

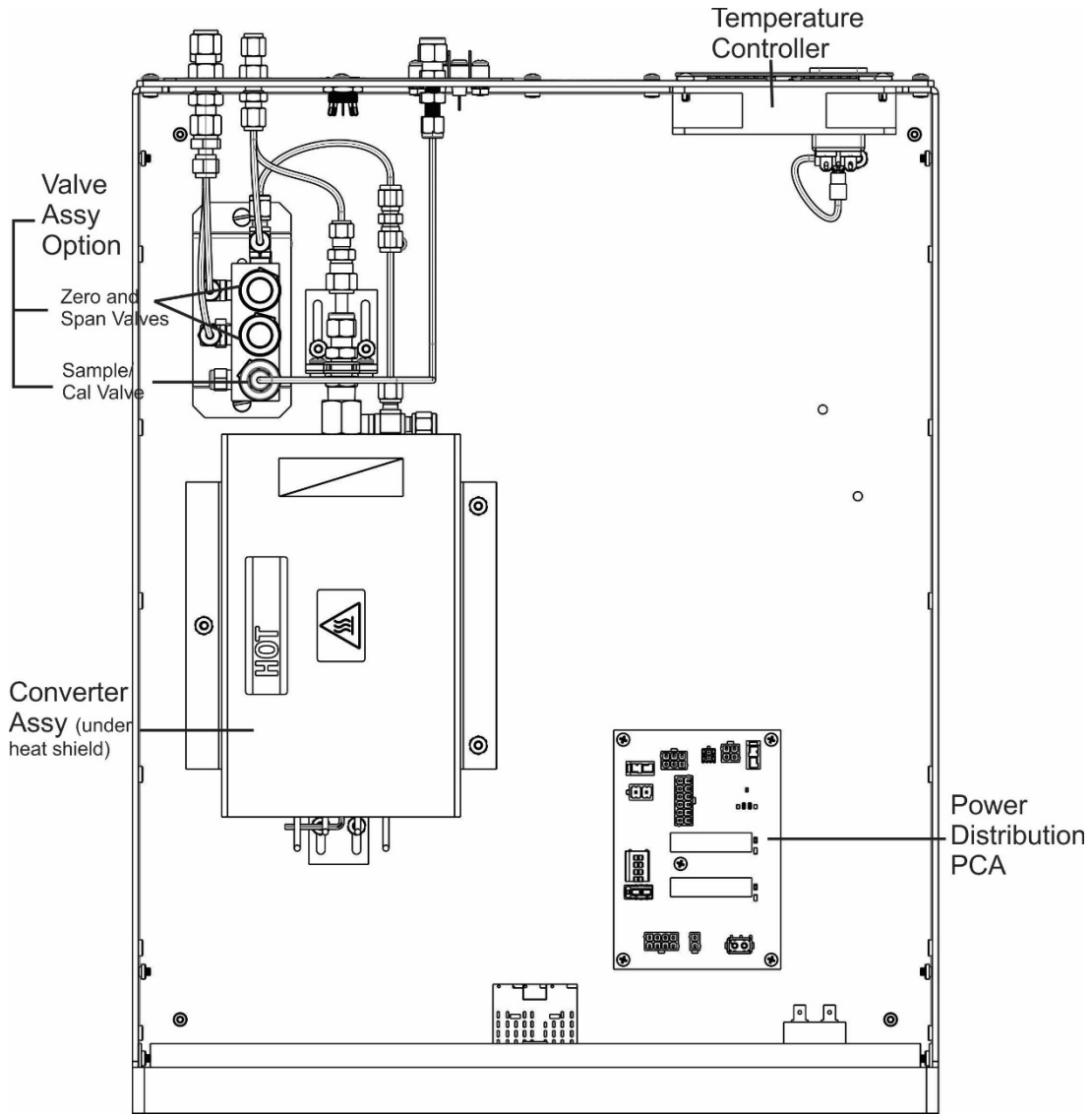

Figure 2-5. Model 501 Internal Chassis Layout

2.3. CONNECTIONS AND STARTUP

This Section presents the electrical (Section 2.3.1) and pneumatic (Section 2.3.2) connections for setting up and preparing the instrument for operation (Section 2.3.3).

2.3.1. ELECTRICAL CONNECTIONS

Note To maintain compliance with EMC standards, cable length must be no greater than 3 meters for all I/O connections.



WARNING – Electrical Shock Hazard

- High Voltages are present inside the instrument's case.
- Power connection must have functioning ground connection.
- Do not defeat the ground wire on power plug.
- Turn off instrument power before disconnecting or connecting electrical subassemblies.
- Do not operate with cover off.



CAUTION – Avoid Damage to the Instrument

Ensure that the AC power voltage matches the voltage indicated on the instrument's model/specs label before plugging it into line power.

2.3.1.1. CONNECTING POWER

Attach the power cord between the instrument's AC power connector and a power outlet capable of carrying at least the rated current at your AC voltage range and ensure that it is equipped with a functioning earth ground. It is important to adhere to all safety and cautionary messages.

2.3.1.2. CONNECTING ANALOG OUTPUTS

The rear panel Analog Output channels A1 through A4 can be mapped to reflect various operating values in the analyzer, including concentration values, temperatures, pressures, etc. These mappings are not configured by default and must be set by the user.

An optional Current Loop output (Section 2.3.1.3) is available for A1, A2 and A3 only.

To access these signals attach a strip chart recorder and/or data-logger to the appropriate analog output connections on the rear panel of the analyzer.

Configure through the Setup>Analog Outputs menu (Section 2.5.8)

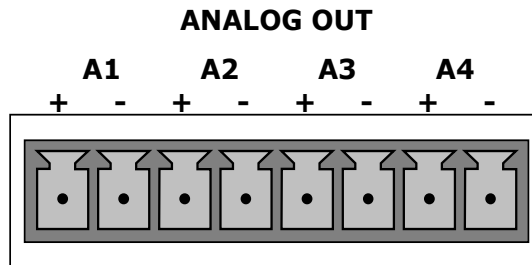

Figure 2-6. Analog Output Connector

Table 2-3. Analog Output Pin Assignments

PIN	ANALOG OUTPUT	SIGNAL OUT	STANDARD VOLTAGE OUTPUT	CURRENT LOOP OPTION
1	A1	User-selected through the Setup>Analog Outputs menu.	V +	I Out +
2			Ground	I Out -
3	A2		V +	I Out +
4			Ground	I Out -
3	A3		V +	I Out +
4			Ground	I Out -
7	A4		V +	Not Available
8			Ground	Not Available

2.3.1.3. CURRENT LOOP ANALOG OUTPUTS (OPTION 41) SETUP

If your analyzer had this option installed at the factory, there are no further connections to be made. Otherwise, it can be installed as a retrofit for each of the analog outputs. This option converts the DC voltage analog output to a current signal with 0-20 mA output current, which can be scaled to any set of limits within that 0-20 mA range. However, most current loop applications call for either 2-20 mA or 4-20 mA range. All current loop outputs have a +5% over-range. Ranges with the lower limit set to more than 1 mA (e.g., 2-20 or 4-20 mA) also have a -5% under-range.

Figure 2-7 provides installation instructions and illustrates a sample configuration of one current output combined with two voltage outputs. Next are instructions for converting current loop analog outputs to standard 0-to-5 VDC outputs. To calibrate or adjust these outputs use the Setup>Analog Outputs menu (Section 2.5.8).



CAUTION – Avoid Invalidating Warranty

Servicing or handling of circuit components requires electrostatic discharge protection, i.e. ESD grounding straps, mats and containers. Failure to use ESD protection when working with electronic assemblies will void the instrument warranty. For information on preventing ESD damage, refer to the manual, Fundamentals of ESD, PN 04786, which can be downloaded from our website at <http://www.teledyne-api.com>.

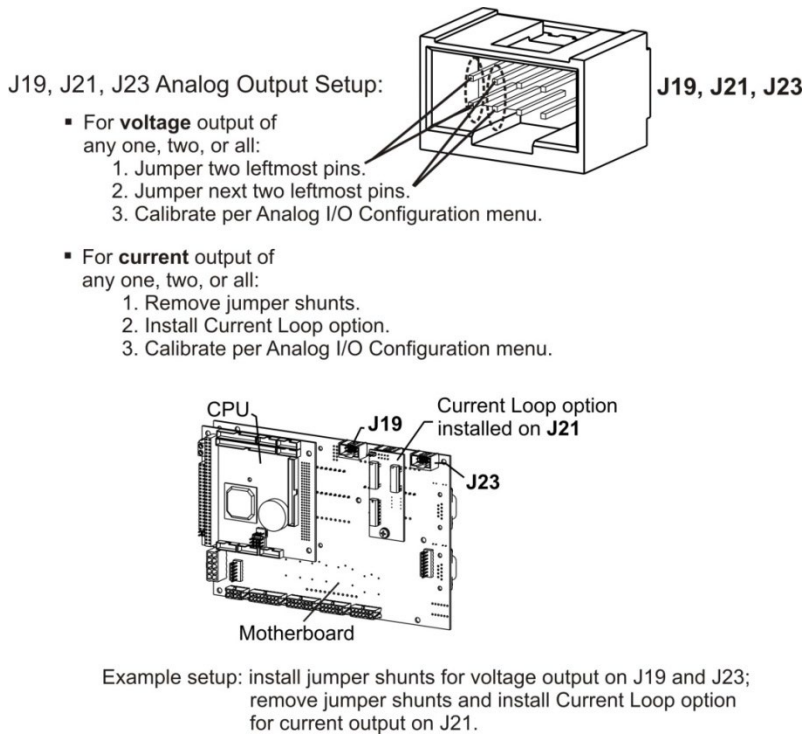

Figure 2-7. Current Loop Option Installed on the Motherboard

CONVERTING CURRENT LOOP ANALOG OUTPUTS TO STANDARD VOLTAGE OUTPUTS

To convert an output configured for current loop operation to the standard 0 to 5 VDC output operation:

1. Turn off power to the analyzer.
2. If a recording device is connected to the output being modified, disconnect it.
3. Remove the top cover.
 - Remove the screws fastening the top cover to the unit (one per side).
 - Slide the cover back and lift the cover straight up.
4. Remove the screw holding the current loop option to the motherboard.
5. Disconnect the current loop option PCA from the appropriate connector on the motherboard (see Figure 2-7).
6. Each connector, J19 and J23, requires two shunts. Place one shunt on the two left most pins and the second shunt on the two adjacent pins (see Figure 2-7).
7. Return the top cover to the analyzer and secure.

The analyzer can now have a voltage-sensing recording device attached to that output.

2.3.1.4. CONNECTING THE STATUS OUTPUTS (DIGITAL OUTPUTS)

The 12-pin STATUS connector allows the digital status outputs to report analyzer conditions (configured through the Setup>Digital Outputs menu) via optically isolated NPN transistors that sink up to 50 mA of DC current. These outputs can be used to interface with devices that accept logic-level digital inputs, such as Programmable Logic Controllers (PLCs). Each status bit is an open collector output that can withstand up to 40 VDC. All of the emitters of these transistors are tied together and available at pin D (see Figure 2-8).

ATTENTION

COULD DAMAGE INSTRUMENT AND VOID WARRANTY

Most PLC's have internal provisions for limiting the current that the input will draw from an external device. When connecting to a unit that does not have this feature, an external dropping resistor must be used to limit the current through the transistor output to less than 50 mA. At 50 mA, the transistor will drop approximately 1.2V from its collector to emitter.

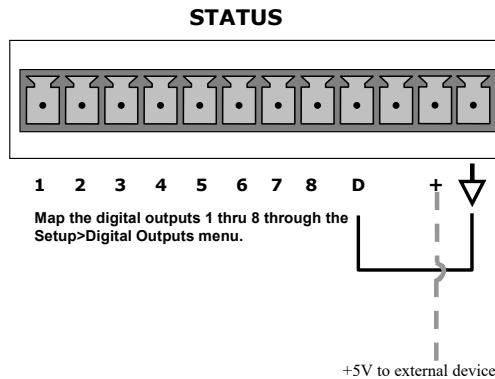

Figure 2-8. Status Output Connector for Digital Outputs

Table 2-4. Status Output Pin Assignments

PIN	STATUS DEFINITION	CONDITION
1-8	Configurable through the Setup>Digital Outputs menu	Collector side of individual status output opto-isolators.
D	Emitter BUS	The emitters of the transistors on pins 1 to 8 are bussed together.
Blank	NO CONNECTION	
+	DC Power	+ 5 VDC, 300 mA source maximum
↓	Digital Ground	The ground level from the analyzer's internal DC power supplies. This connection should be used as the ground return when +5VDC power is used.

2.3.1.5. CONNECTING THE CONTROL INPUTS (DIGITAL INPUTS)

With zero and span valves option installed, two digital control inputs in the rear panel CONTROL IN connector, can be used to remotely activate the zero and span calibration modes (see Section 4.2.2.1).

Energize the Control Inputs either by the internal +5V available from the pin labeled “+” (more convenient), or by a separate external 5 VDC power supply (ensures that these inputs are truly isolated). Refer to Figure 2-9.

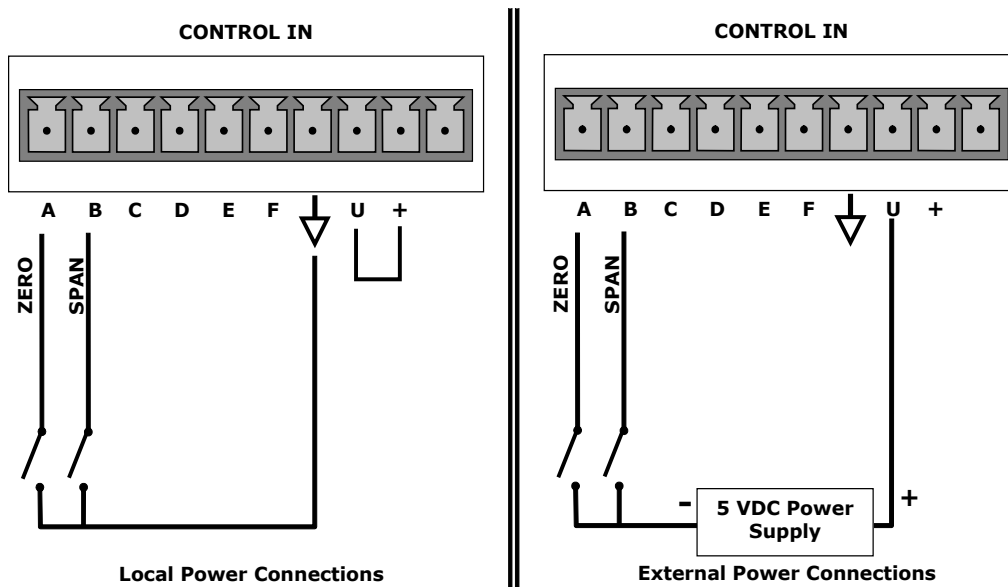



Figure 2-9. Energizing the Control Inputs

Table 2-5. Control Input Pin Assignments

INPUT #	STATUS DEFINITION	ON CONDITION
A	Remote Zero Cal	The analyzer is placed in Zero Calibration mode.
B	Remote Span Cal	The analyzer is placed in Lo Span Calibration mode.
C, D, E & F	Spare	
	Digital Ground	The ground level from the analyzer's internal DC Power Supplies (same as chassis ground).
U	External Power input	Input pin for +5 VDC is required to activate pins A – F.
+	5 VDC output	Internally generated 5V DC power. To activate inputs A – F, place a jumper between this pin and the “U” pin. The maximum amperage through this port is 300 mA (combined with the analog output supply, if used).

2.3.1.6. CONNECTING THE ANALYZER TO THE EXTERNAL CONVERTER

With the Zero/Span option, it is required that the umbilical cord P/N 02255 be connected between the T201 analyzer’s rear panel “MULTI” connector (Figure 2-2) and the external 501 NH₃ converter’s rear panel “UMBILICAL” connector (Figure 2-3).

2.3.1.7. CONCENTRATION ALARM RELAY (OPTION 61)

The concentration relay option provides four (4) “dry contact” relays on the rear panel (Figure 2-10), each with 3 pins: Common (C), Normally Open (NO), and Normally Closed (NC). The Relays can be mapped to reflect various internal instrument conditions and states. Configure these outputs through the Setup>Digital Outputs menu (Section 2.5.7) under MB Relay [1 thru 4].

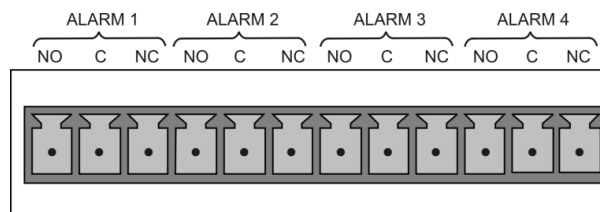

Figure 2-10. Concentration Alarm Relay

For the converter Alarm Output, the rear panel of the 501 includes a terminal strip (see Figure 2-3) by which connections can be made to the converter’s internal temperature alarm. The settings are preset at the factory.

- Connect the input leads of your alarm-sensing device (e.g. datalogger) to the center two pins of the alarm output connector.
- Make sure the load does not exceed the rated capacity of the relay.

2.3.1.8. CONNECTING COMMUNICATIONS INTERFACES

ETHERNET CONNECTION

For network or Internet communication with the analyzer, connect an Ethernet cable from the analyzer's rear panel Ethernet interface connector to an Ethernet port. Although the analyzer is shipped with DHCP enabled by default, it should be manually configured with a static IP address.

Configuration: Section 2.5.10.5

USB (OPTION) CONNECTION

The rear panel USB option is for direct communication between the analyzer and a PC. Connect a USB cable between the analyzer and a computer USB port. Computer and instrument baud rates must match.

Note If this option is installed, the rear panel RS232 (COM2) port cannot be used for anything other than RS-232 Multidrop communication.

RS-232 CONNECTION

For RS-232 communications with data terminal equipment (DTE) or with data communication equipment (DCE) connect either a DB9-female-to-DB9-female cable (Teledyne API part number WR000077) or a DB9-female-to-DB25-male cable (Option 60A), as applicable, from the analyzer's RS-232 port (see Figure 2-11 for connector pin

assignments) to the device. Adjust the rear panel DCE-DTE switch to select DTE or DCE as appropriate (Section 3.1).

Configuration: Section 3.2.1 and Section 3.5.2 (for Hessen protocol)

Important

IMPACT ON READINGS OR DATA

Cables that appear to be compatible because of matching connectors may incorporate internal wiring that makes the link inoperable. Check cables acquired from sources other than Teledyne API for pin assignments (Figure 2-11) before using.

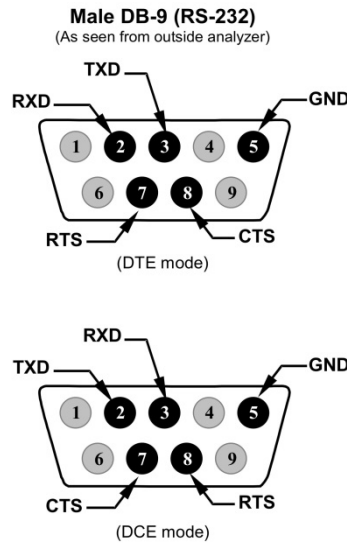

Figure 2-11. Rear Panel Connector Pin-Outs for RS-232 Mode

The signals from these two connectors are routed from the motherboard via a wiring harness to two 10-pin connectors on the CPU card, J11 and J12 (Figure 2-12).

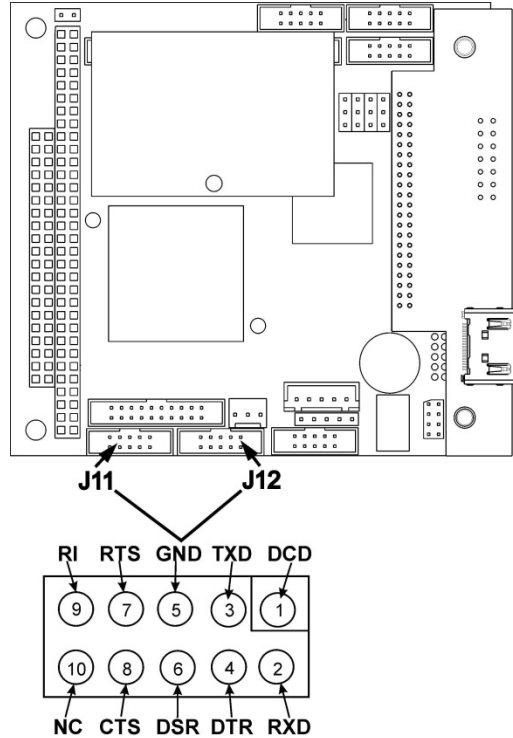

Figure 2-12. Default Pin Assignments for CPU COM Port Connector (RS-232)

Teledyne API offers two mating cables, one of which should be applicable for your use.

- P/N WR000077, a DB-9 female to DB-9 female cable, 6 feet long. Allows connection of the serial ports of most personal computers.
- P/N WR000024, a DB-9 female to DB-25 male cable. Allows connection to the most common styles of modems (e.g. Hayes-compatible) and code activated switches.

Both cables are configured with straight-through wiring and should require no additional adapters.

To assist in properly connecting the serial ports to either a computer or a modem, there are activity indicators just above the RS-232 port. Once a cable is connected between the analyzer and a computer or modem, both the red and green LEDs should be on.

- If the lights are not lit, locate the small switch on the rear panel to switch it between DTE and DCE modes.
- If both LEDs are still not illuminated, ensure that the cable properly constructed.

Received from the factory, the analyzer is set up to emulate an RS-232 DCE device. (View these parameters in the Setup>Comm>COM1[COM2] menu).

RS-232 (COM1): RS-232 (fixed) DB-9 male connector

- **Baud rate:** 115200 bits per second (baud)
- **Data Bits:** 8 data bits with 1 stop bit
- **Parity:** None

COM2: RS-232 (configurable to RS 485), DB-9 female connector

- **Baud rate:** 19200 bits per second (baud)
- **Data Bits:** 8 data bits with 1 stop bit
- **Parity:** None

RS-232 MULTIDROP (OPTION 62) CONNECTION

When the RS-232 Multidrop option is installed, connection adjustments and configuration through the menu system are required. This Section provides instructions for the internal connection adjustments, then for external connections, and ends with instructions for menu-driven configuration.

Note

Because the RS-232 Multidrop option uses both the RS232 and COM2 DB9 connectors on the analyzer's rear panel to connect the chain of instruments, COM2 port is no longer available for separate RS-232 or RS-485 operation.

ATTENTION

COULD DAMAGE INSTRUMENT AND VOID WARRANTY

Printed Circuit Assemblies (PCAs) are sensitive to electro-static discharges too small to be felt by the human nervous system. Failure to use ESD protection when working with electronic assemblies will void the instrument warranty. For information on preventing ESD damage, refer to the manual, Fundamentals of ESD, PN 04786, which can be downloaded from our website at <http://www.teledyne-api.com> under Help Center > Product Manuals in the Special Manuals section.

In each instrument with the Multidrop option there is a shunt jumpering two pins on the serial Multidrop and LVDS printed circuit assembly (PCA), as shown in Figure 2-13. This shunt must be removed from all instruments except that designated as last in the multidrop chain, which must remain terminated. This requires powering off and opening each instrument and making the following adjustments:

1. With **NO power** to the instrument, remove its top cover and lay the rear panel open for access to the Multidrop/LVDS PCA, which is seated on the CPU.
2. On the Multidrop/LVDS PCA's JP2 connector, remove the shunt that jumpers Pins 21 ↔ 22 as indicated in Figure 2-13. (Do this for all but the last instrument in the chain where the shunt should remain at Pins 21 ↔ 22).
3. Check that the following cable connections are made in *all* instruments (again refer to Figure 2-13):
 - J3 on the Multidrop/LVDS PCA to the CPU's COM1 connector
(Be aware that the CPU's COM2 connector is not used in Multidrop)
 - J4 on the Multidrop/LVDS PCA to J12 on the motherboard
 - J1 on the Multidrop/LVDS PCS to the front panel LCD

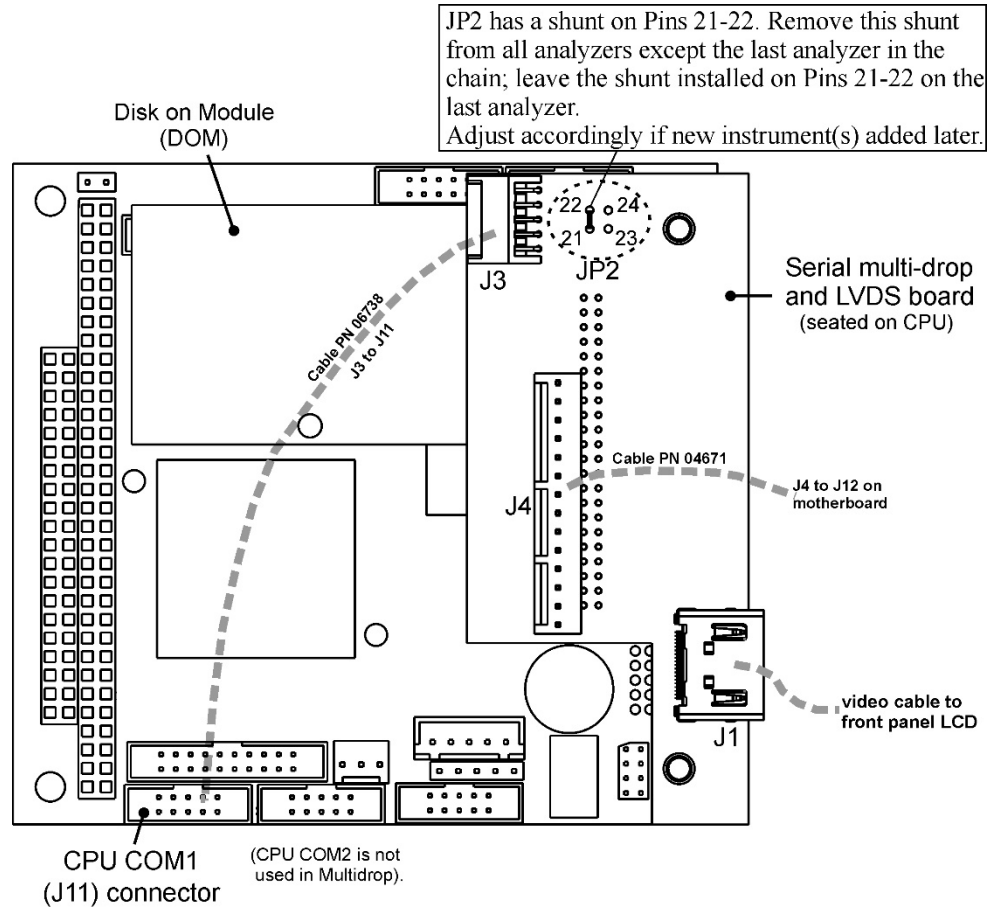

Figure 2-13. Jumper and Cables for Multidrop Mode

Note

If you are adding an instrument to the end of a previously configured chain, remove the shunt between Pins 21 and 22 of JP2 on the Multidrop/LVDS PCA in the instrument that was previously the last instrument in the chain.

4. Close the instrument.
5. Referring to Figure 2-14 use straight-through DB9 male → DB9 female cables to interconnect the host RS232 port to the first analyzer's RS232 port; then from the first analyzer's COM2 port to the second analyzer's RS232 port; from the second analyzer's COM2 port to the third analyzer's RS232 port, etc., connecting in this fashion up to eight analyzers, subject to the distance limitations of the RS-232 standard.
6. On the rear panel of each analyzer, adjust the DCE DTE switch so that the green and the red LEDs (RX and TX) of the COM1 connector (labeled RS232) are both lit. (Ensure you are using the correct RS-232 cables internally wired specifically for RS-232 communication; see Figure 2-12).

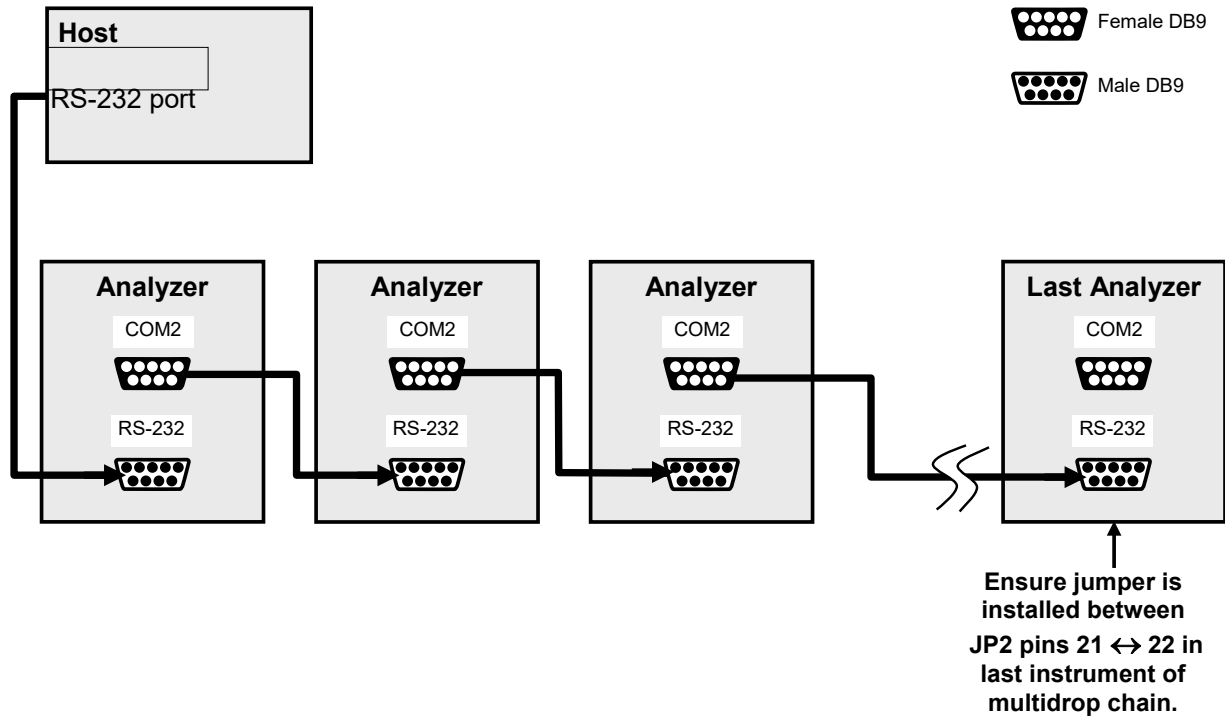

Figure 2-14. RS-232 Multidrop PCA Option Host/Analyzer Interconnect Diagram

7. BEFORE communicating from the host, power on the instruments and check that the user-selectable Instrument ID is unique for each: in the Setup>Vars menu, check Instrument ID in the list of variables. To change, select the variable and press the Edit button; once changed, press the Enter button.
8. Next, in the Setup>Comm>COM1 menu (do not use the COM2 menu for multidrop), use the Edit button to set COM1 Quiet Mode and COM1 Multidrop to ENABLED; then press the Accept button.
9. Also check the COM1 Baud Rate to ensure it reads the same for all instruments (edit if needed and press the Accept button).

Note

The (communication) Host instrument can address only one instrument at a time, each by its unique ID (see step 7 above).

Note

Teledyne API recommends setting up the first link, between the Host and the first analyzer, and testing it before setting up the rest of the chain.

2.3.2. PNEUMATIC CONNECTIONS

This Section provides pneumatic connection and setup instructions for basic and optional configurations. Pneumatic flow diagrams are shown in Section 2.3.3. Calibration instructions are provided in Section 4.

Before making the pneumatic connections, carefully note the following cautionary and special messages:



CAUTION

Do not pressurize the Sample/Span/Zero port above ambient.



CAUTION – General Safety Hazard

Do not vent calibration gas or sample gas into enclosed areas.

ATTENTION

COULD DAMAGE INSTRUMENT AND VOID WARRANTY

Vent Pressurized Gas:

When any gas (span, zero air, sample) is received from a pressurized manifold, always provide a vent to equalize the pressure with the ambient atmosphere before it enters the instrument to ensure that the gases input do not exceed the instrument's maximum inlet pressure, as well as to prevent back diffusion and pressure effects

Remove Dust Plugs:

Remove dust plugs from rear panel exhaust and supply line fittings before powering on the instrument.

Keep dust plugs for reuse in future storage or shipping to prevent debris from entering the pneumatics.

2.3.2.1. SPECIAL CONSIDERATIONS FOR TUBING AND FITTINGS

Ammonia is a difficult gas to measure due to its chemical characteristics. The gas tends to adsorb onto surfaces and diffuse into many materials. The following precautions should be observed when designing ammonia sampling systems and connecting them to the T201 analyzer:

- Do NOT use copper tubing or fittings designed for household plumbing.
- Use ONLY Chromatography grade (cleaned, passivated) stainless steel tubing.
- Use ONLY glass for sample inlet manifold.
- ALWAYS keep the tubing from the calibrator to the analyzer as short as possible. USE stainless steel tubing throughout, especially from the ammonia calibration bottle to the calibrator.
- If possible, HEAT the sample line and DRY the sample gas.

- Sample filters will cause response delays on both the rise and fall of the sample signal (see more about sample filtration in Section 2.3.2.2).

These rules apply also to your calibrator's internal plumbing. When used with the T201, the calibrator must have stainless steel plumbing throughout. Any calibrator that contains Teflon tubing and/or internal MFC's that can be affected by the ammonia gas is not recommended for use with the T201 analyzer. It is important to keep the sampling system well maintained.

Pressure:

- All Sample gas pressure must be at ambient atmospheric pressure, no greater than 1.0 psig.

Venting (to prevent back diffusion and pressure effects):

- Run tubing outside the enclosure or at least away from immediate area surrounding the instrument.

Exhaust Outlet:

- Run tubing outside the enclosure.

2.3.2.2. SAMPLE FILTRATION

A sample filter resides in the T201 pneumatic pathway. The filter is a 1/4" diameter stainless steel sintered filter used to protect the reaction cell flow control orifice from plugging. This filter will plug rapidly if contaminated sample gas is not filtered before entering the analyzer.

Note

In situations where the sample gas is known to be contaminated with particulate material, it is advisable to add extra filtration. However, it must be noted that the response time is directly extended through filter additions.

2.3.2.3. PNEUMATIC CONNECTIONS T201, 501, EXTERNAL CALIBRATOR

In the following pneumatic connections illustration, the dashed line represents the stainless tubing for the Zero/Span (Z/S) valve option, which includes its own vent as shown. When the option is used, cap the calibrator rear output ports to avoid having more than one vent.

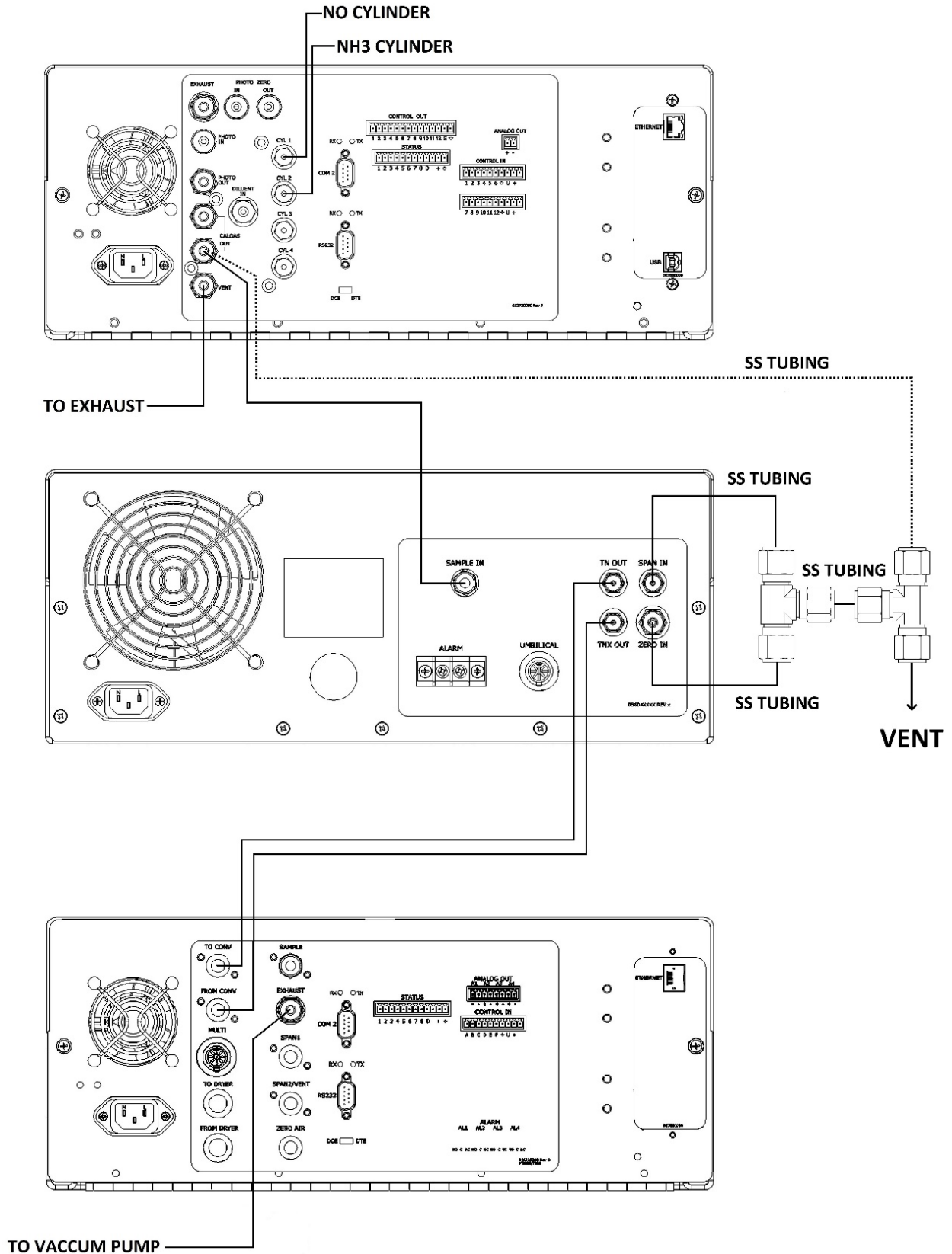

Figure 2-15. Pneumatic Connections (bottom to top) T201>501>External Calibrator Option (ECO)

Note

When connecting the T201 with the 501:

- The T201 rear panel port labeled “TO CONV” serves as the TN IN port plumbed from the “TN OUT” port of the 501.
- The T201 rear panel port labeled “FROM CONV” serves as the TNX IN port plumbed from the “TNX OUT” port of the 501.
- The ECO’s connection instructions can be found in its respective manual.

If the analyzer is purchased without the Zero/Span option, then the zero and span calibration gases must be individually applied to the Sample port.

Note

- The zero and span gases must be clean/dry and supplied at ambient pressure.
- Oxygen (O₂) MUST be present in the sample stream for the converters to work properly.

2.3.2.4. BASIC CONNECTIONS FROM CALIBRATOR

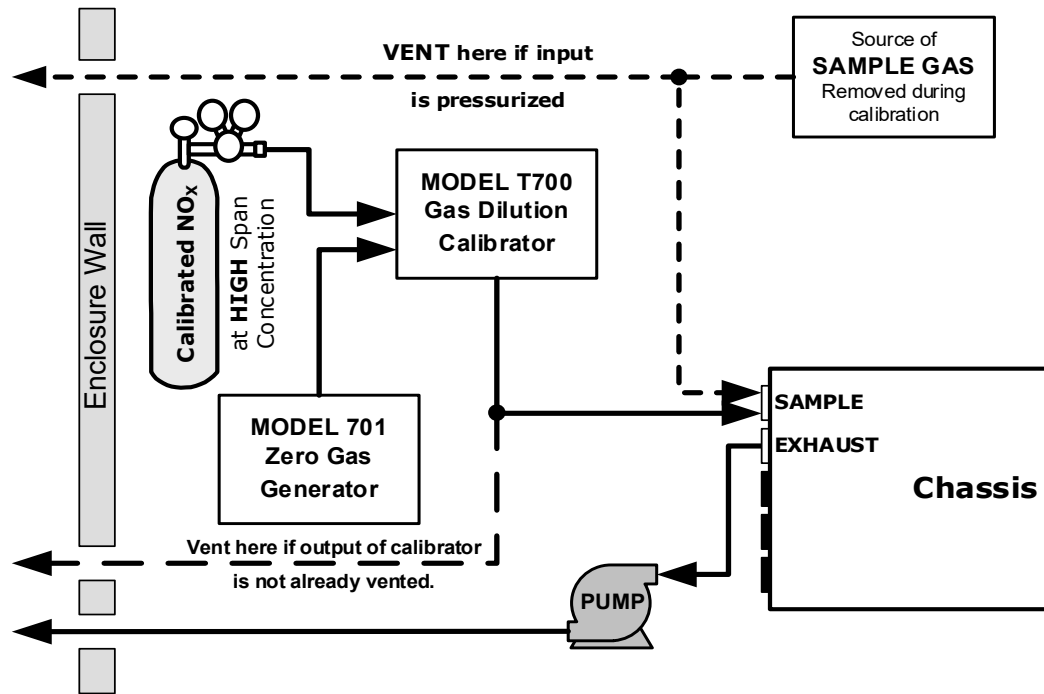

Figure 2-16. Gas Line Connections from Calibrator – Basic Configuration

For the analyzer’s basic configuration, in addition to tubing, pressure, venting, and exhaust requirements set out in Section 2.3.2.1, attach the following pneumatic lines:

SAMPLE GAS SOURCE

Connect a sample gas line to the SAMPLE inlet.

CALIBRATION GAS SOURCES

CAL GAS & ZERO AIR SOURCES: The source of calibration gas is attached to the SAMPLE inlet, but only when a calibration operation is actually being performed.

VENTING

Vent the output of the calibrator if calibrator not already vented.

SAMPLE GAS CONDITIONER

The T201 includes two permeation gas exchange tubes, which:

- remove H₂O from the ozone generator supply gas stream to a dew point of about -20° C (~600 ppm H₂O)
- effectively remove concentrations of ammonia (NH₃) up to about 1 ppm from the sample stream.

2.3.3. PNEUMATIC FLOW DIAGRAMS

This Section shows the basic pneumatic flow diagrams for the T201 analyzer with 501 converter in basic configuration and with the zero and span valves option. .

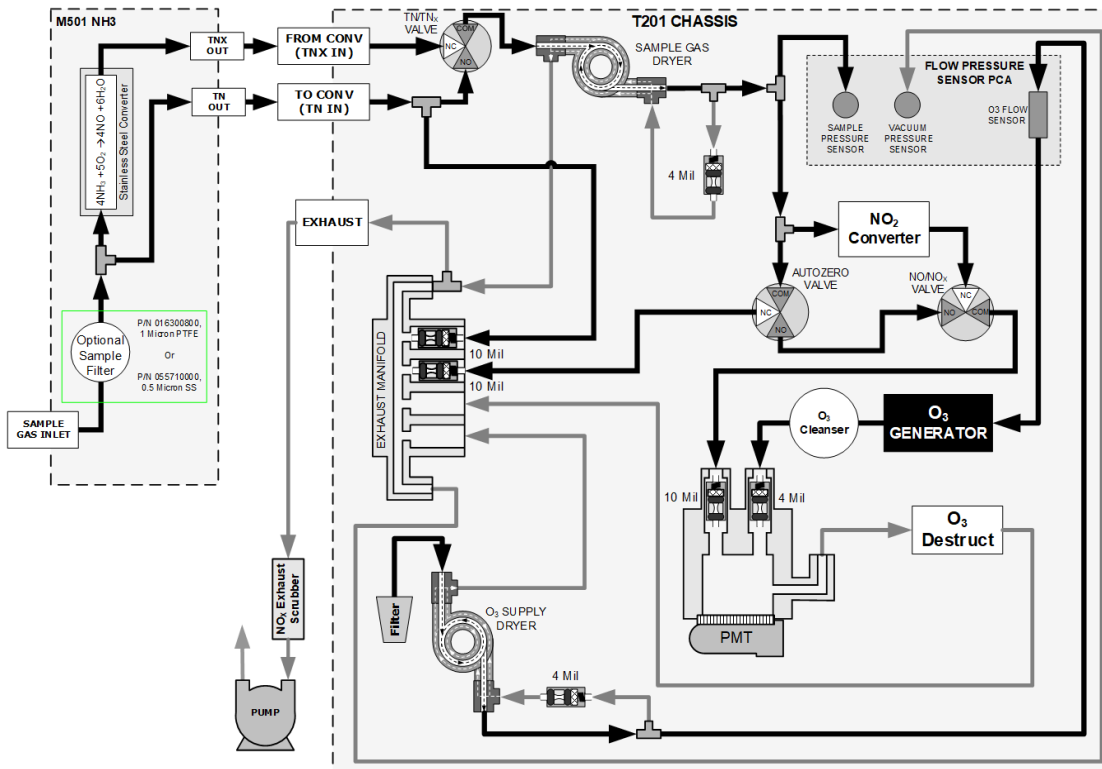

Figure 2-17. T201 and 501 NH₃ Pneumatic Flow

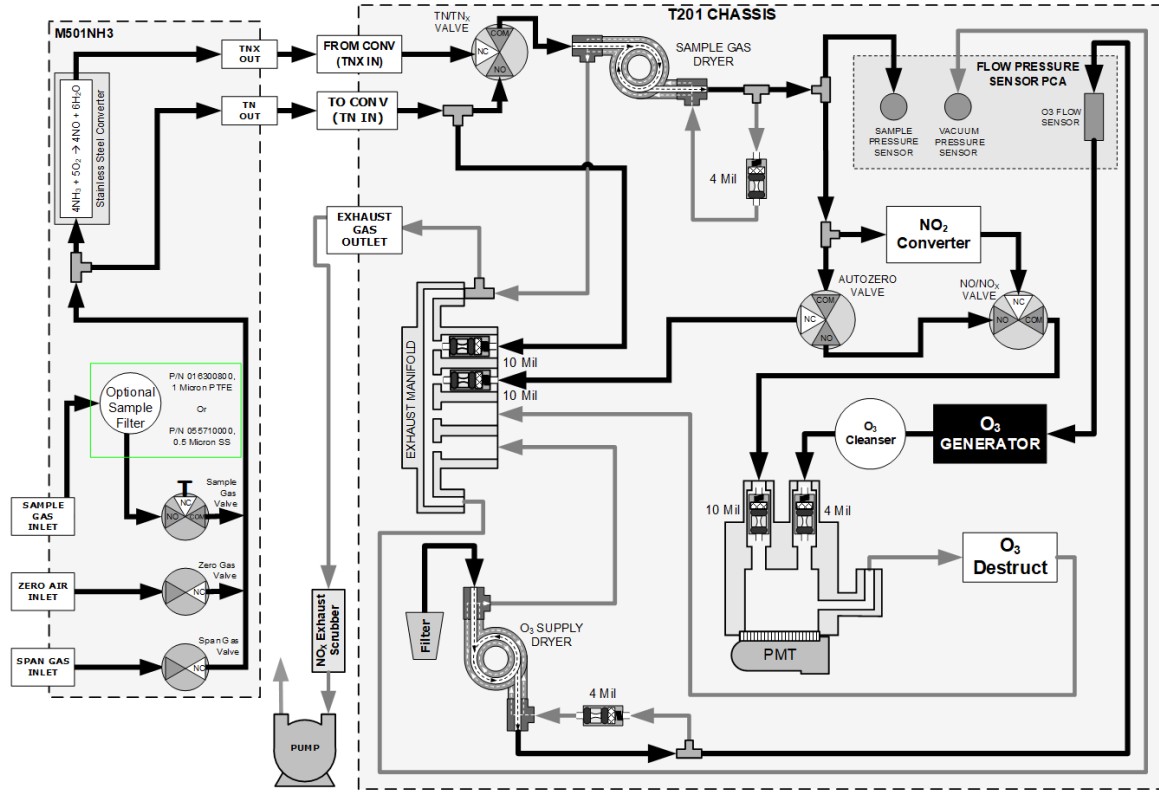

Figure 2-18. T201 and 501 NH₃ with Zero/Span Valves Option Pneumatic Flow

2.3.4. STARTUP, FUNCTIONAL CHECKS AND CALIBRATION

We recommend reading Section 6 to become familiar with the principles of operation.

When the instrument is first started (Section 2.3.4.1), check its functionality (Section 2.3.4.3) and run an initial calibration (Section 2.3.4.4). Section 2.4 introduces the menu system, and Section 2.5 provides setup/customization instructions.

CAUTION!



If the presence of ozone is detected at any time, power down the instrument and contact Teledyne API Technical Support as soon as possible:

+1 800-324-5190 or email: api-techsupport@teledyne.com

CAUTION!



The Model 501 ammonia converter operates at 825 °C: do not flow highly flammable gases through the T201 analyzer.

Note

If the block temperature warning exhibits a negative number such as (-37), then the umbilical cord is probably not attached or the Thermistor has become disconnected.

Note

When the analyzer is not in use, it is advisable to turn off the 501 NH₃ converter. If the converter hasn't been powered for an extended period of time it is recommend that the analyzer be operated overnight prior to use.

2.3.4.1. STARTUP

Upon initial startup, a sequence of status screens (Figure 2-19) appear prior to the Home page (Figure 2-20).

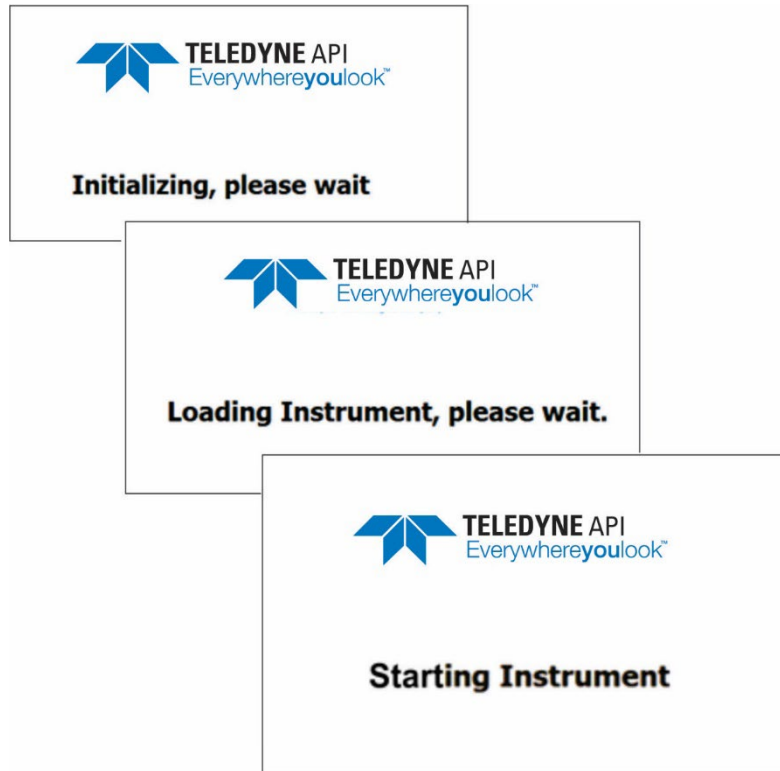

Figure 2-19. Status Screens at Startup

Upon any startup, this instrument should warm up for approximately one hour before reliable measurements can be taken.

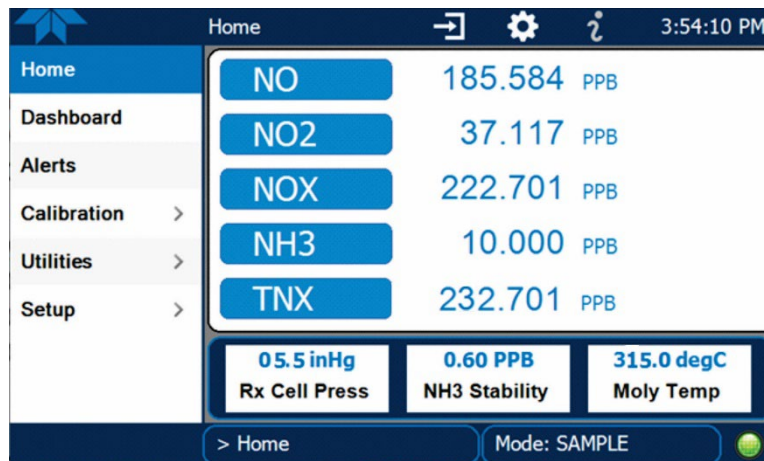

Figure 2-20. Home Page Example

2.3.4.2. ALERTS: WARNINGS AND OTHER MESSAGES

Because internal temperatures and other conditions may be outside the specified limits during the warm-up period, the software will suppress most Alerts for 30 minutes after power up. The Alerts page (Figure 2-21) shows the status of any active warning conditions or user-configured Events. (Section 2.4.3 provides more detailed information about Alerts, and Section 2.5.2 addresses Events).

Alerts can be viewed via either the Alerts menu or the Alerts shortcut (Caution symbol, bottom right corner of the screen). Although these alerts can be cleared from the Active Alerts page, a history of all alerts remains in the Utilities>Alerts Log page.

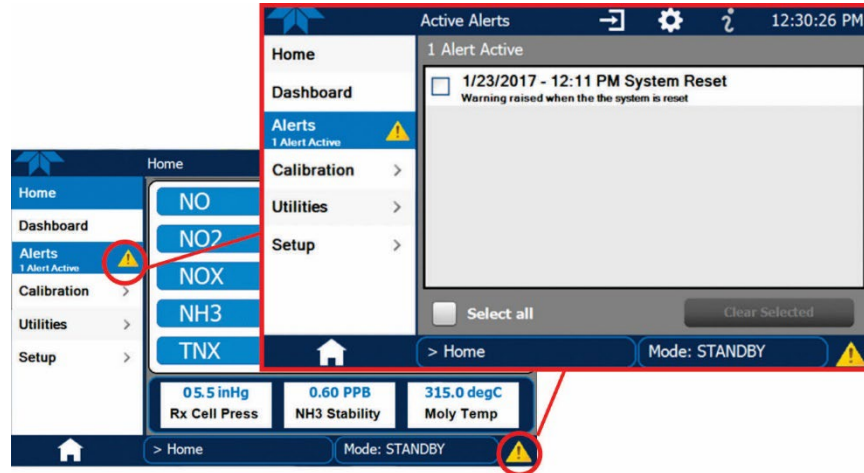

Figure 2-21. Alerts Page

If Alerts about warning conditions persist after the warm up period or after being cleared, investigate their cause using the troubleshooting guidelines in Section 5.7.

2.3.4.3. FUNCTIONAL CHECKS

After warm-up, verify that the software properly supports any hardware options that are installed (Setup>Instrument menu), and that the instrument is functioning within allowable operating parameters. Check the Dashboard page against the instrument’s *Final Test and Validation Data sheet*, which lists these values as they appeared before the instrument left the factory. (If any functional parameters are not displayed, configure the Dashboard through the Setup>Dashboard menu to add them; see Section 2.4.2).

These functions are also useful tools for diagnosing problems (information provided in Section 5.7.2).

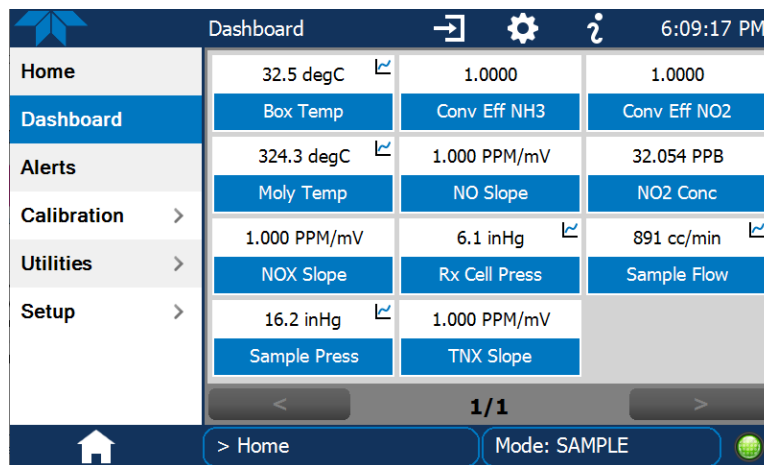

Figure 2-22. Sample Dashboard Page

2.3.4.4. CALIBRATION

Before operation begins, the analyzer requires zero and span calibrations (as a basic rule, always zero first, then span), and possibly HVPS adjustment, followed by calibration of the converter efficiency (CE) points. Also, any time an analyzer is moved or its configuration changed, it must be calibrated. The method for performing a calibration differs slightly depending on whether or not the zero/span valves option is installed. Follow the appropriate calibration instructions presented in Section 4.

2.4. MENU OVERVIEW

Table 2-6 describes the main menus and provides cross-references to the respective sections with configuration details.

Table 2-6. Menu Overview

MENU	DESCRIPTION	LOCATION
Home	View and plot concentration readings and other selectable parameter values (Figure 2-24).	Section 2.4.1
Dashboard	View user-selected parameters and their values, some of which can be displayed in a live-plot graph (Figure 2-25).	Section 2.4.2
Alerts	View and clear active Alerts that were triggered by factory-defined Events as well as user-defined Events. (Active and past Alerts are recorded in the Utilities>Alerts Log).	Section 2.4.3
Calibration	Run calibrations on the gas channels and calibrate converter efficiency points.	Sections 2.4.4 and 4
Utilities	View logs, download data and firmware updates, copy configurations between instruments, and run diagnostics.	Section 2.4.5
Setup	Configure a variety of features and functions through these submenus for customized operation.	Section 2.5
Datalogging	Track and record concentration and calibration data and selectable diagnostic parameters, the reports for which can be viewed in the Utilities>Datalog View menu (Section 2.4.5) and downloaded to a flash drive via the Utilities>USB Utilities menu (Section 2.4.5). Also, select configured Events (Section 2.5.2) and create customized triggers for data logging functions.	Section 2.5.1
Events	Select parameters and define the conditions by which they are to be flagged and recorded in the Alerts log (Section 2.4.3) when they are triggered. Once configured, Events can be used to trigger Datalogs. (Section 2.5.1). Note that some Events are predefined and are not editable.	Section 2.5.2
Dashboard	Monitor instrument functionality (Figure 2-22) via selectable parameters.	Section 2.5.3
Auto Cal (with valve options)	When zero/span valve options installed, configure sequences for automatic calibration functions.	Section 4.3
Vars	Manually adjust several software variables that define specific operational parameters.	Section 2.5.5
Homescreen	Select up to three parameters to be displayed in the meters (Figure 2-23).	Section 2.5.6
Digital Outputs	Map the rear-panel digital outputs to a variety of signals present in the instrument to monitor the status of operating conditions or custom Events.	Section 2.5.7
Analog Outputs	Send user-selected parameter readings in the form of user-defined voltage or current loop signals as outputs to a strip chart recorder and/or the data logger.	Section 2.5.8
Instrument	View product and system information, including list of options, if any; view network settings; view/adjust Date and Time settings*; and check for firmware updates when connected to a network that is connected to the Internet. *Time Zone change requires special procedures (Section 5.5).	Section 2.5.9
Comm	View and configure network and serial communications.	Section 2.5.10

2.4.1. HOME PAGE

Figure 2-23 presents an orientation to the main display screen; Figure 2-24 shows that pressing the gas name or its concentration value or a meter below displays a live plot of their respective readings. Section 2.5.6 provides configuration instructions.

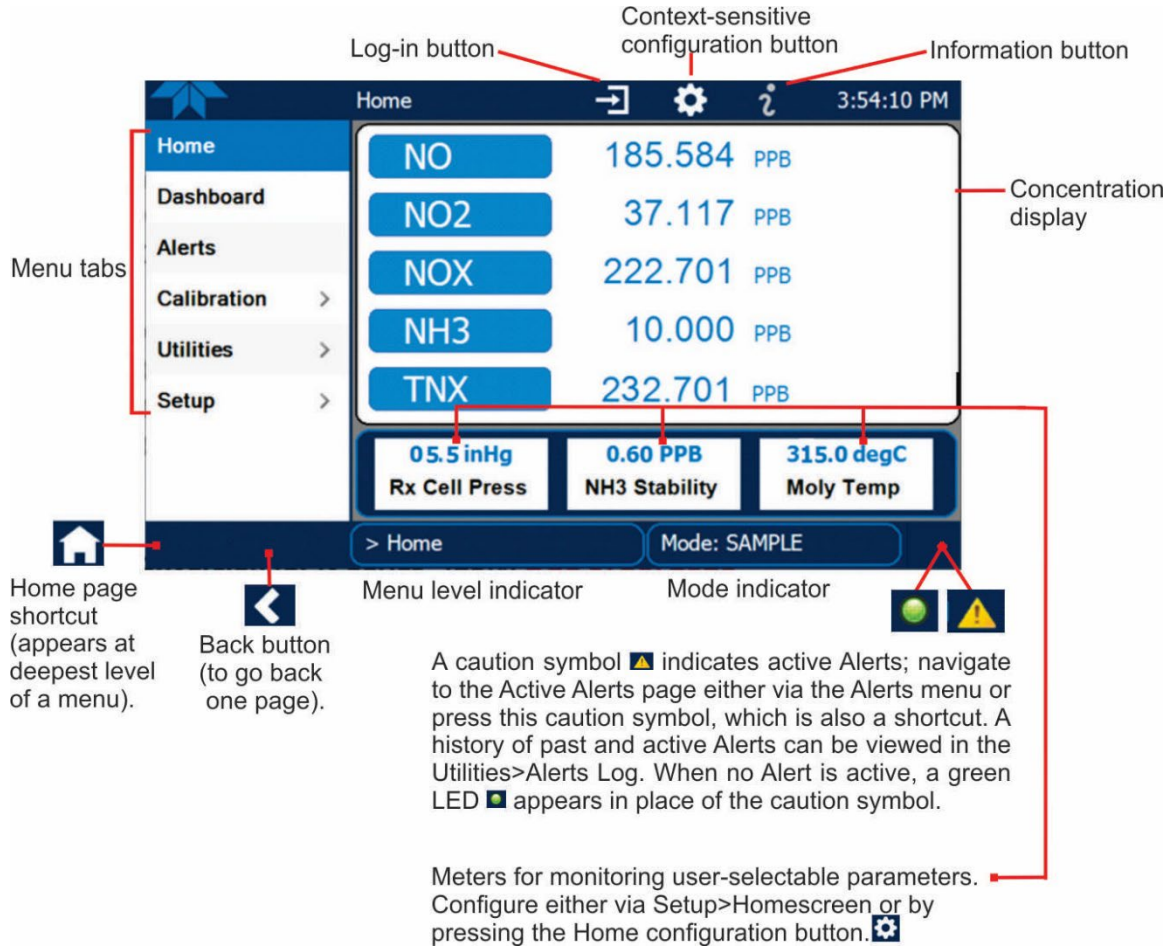

Figure 2-23. User Interface Orientation

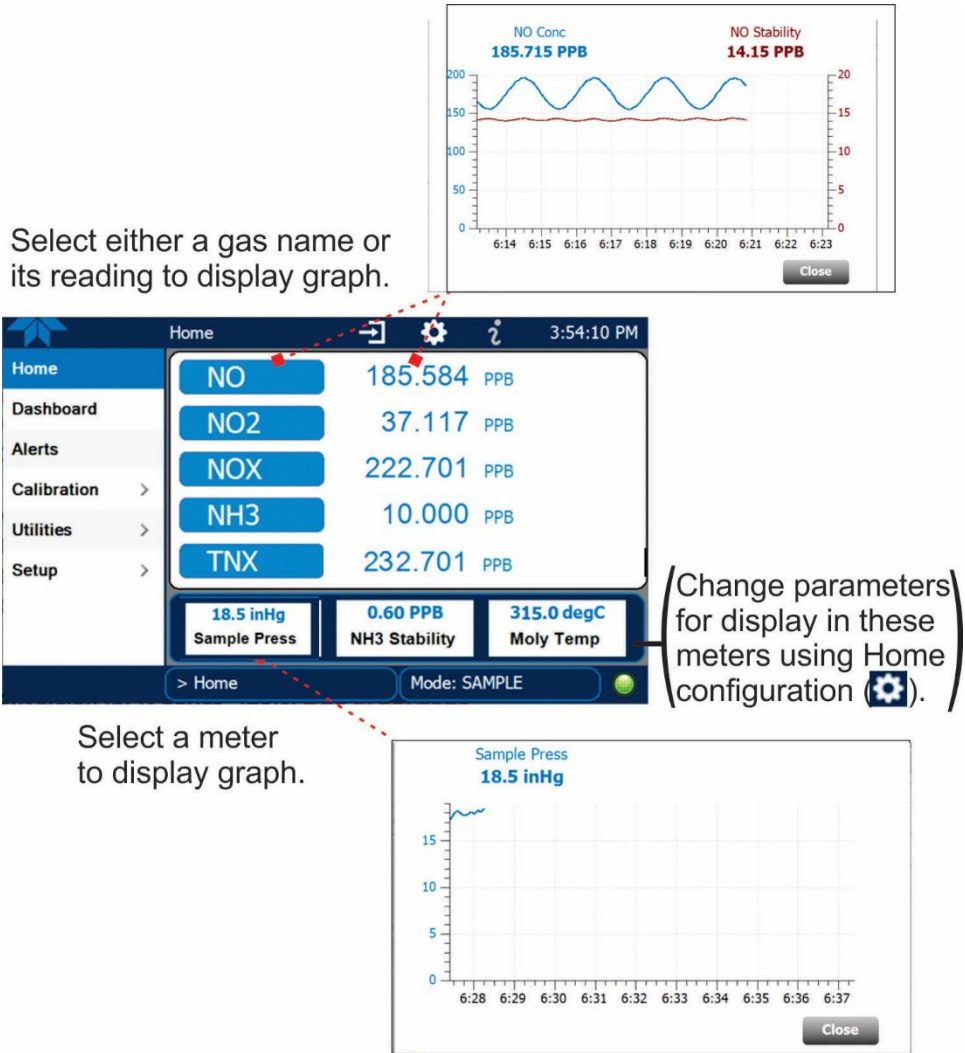
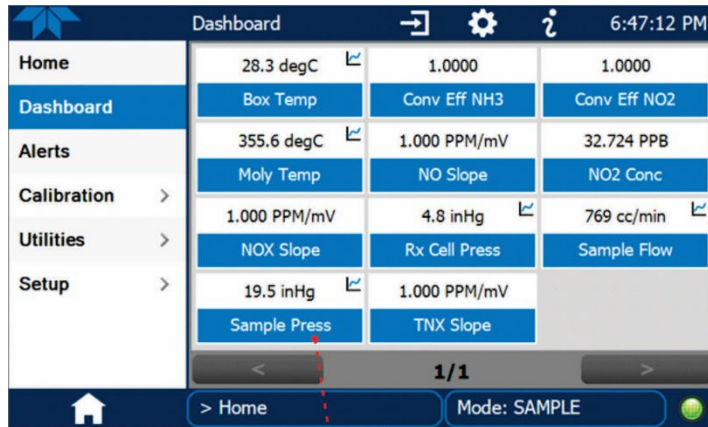

Figure 2-24. Concentration and Stability Graph (top) and Meter Graph (bottom)

2.4.2. DASHBOARD

The Dashboard displays an array of user-selectable parameters and their values (Section 2.5.3 provides configuration instructions). If there is a graphing icon in the upper right corner of a parameter, pressing that parameter displays a live plot of its readings as in Figure 2-25.



Select a graphable parameter in the Dashboard page to view a live plot.

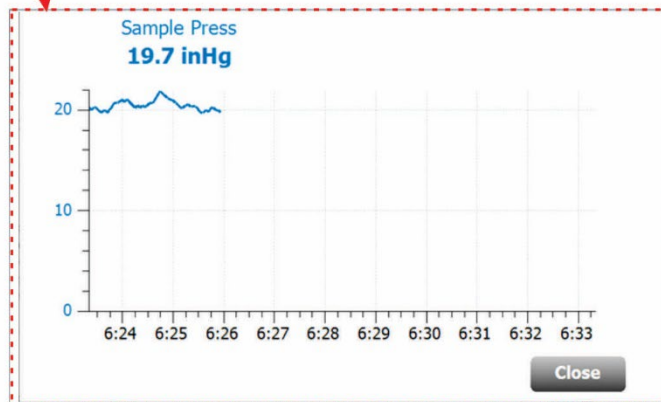

Figure 2-25. Dashboard Page

2.4.3. ALERTS

Alerts are notifications triggered by specific criteria having been met by either factory-defined conditions (standard and not editable) or user-defined Events (Section 2.5.2). The Active Alerts page shows the status of any active warning conditions or Events that have been triggered.

When Alerts are triggered, a caution symbol appears in both the Alerts menu tab and in the bottom right corner of the software interface, which serves as a shortcut to the Alerts page from any other page. View a list of currently active Alerts by pressing either the Alerts menu on the Home screen or by pressing the Alerts shortcut (Figure 2-26).

While Alerts can be cleared from the Active Alerts page, they remain recorded in the Utilities>Alerts Log menu.

Navigate to the Active Alert page via the Alerts menu on Home screen.

(Also view a list of all active and past Alerts and Events via Utilities>Alerts Log).

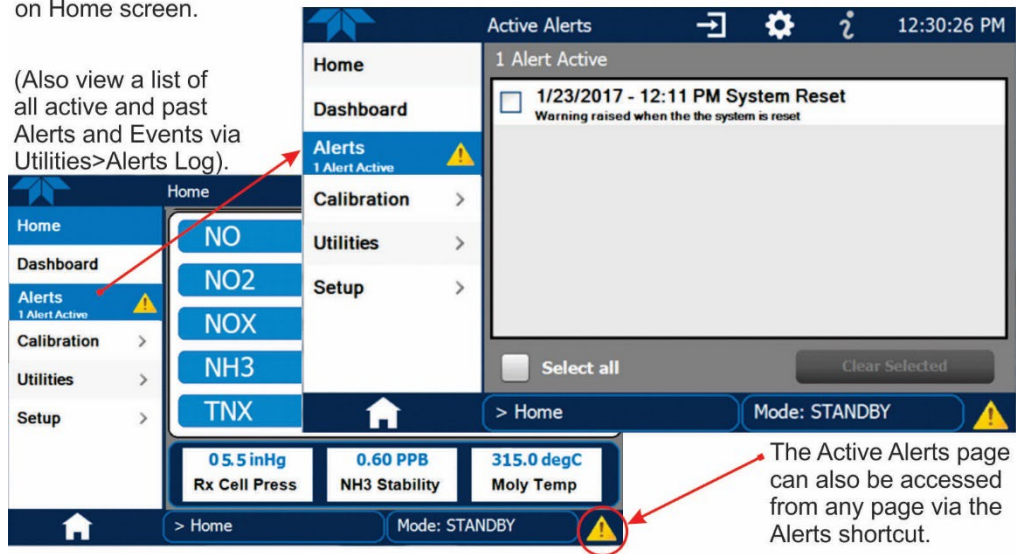

Figure 2-26. Navigating to the Active Alerts Page

Alerts can be configured as either latching (appears in Active Alerts screen when Event is triggered and must be cleared by the user) or non-latching (Active Alerts screen continuously updates based on the Event criteria, clearing on its own). See Section 2.5.2.

To clear Alerts from the Active Alerts page, either check individual boxes to choose specific Alerts, or check the Select All box to choose all Alerts, then press the Clear Selected button.

When all Alerts are cleared, the Alerts menu tab no longer shows the caution symbol, and a green LED replaces the caution symbol in the bottom right corner of the interface (Figure 2-27). However, Alerts can reappear if the conditions causing them are not resolved. For troubleshooting guidance, refer to Section 5.7.

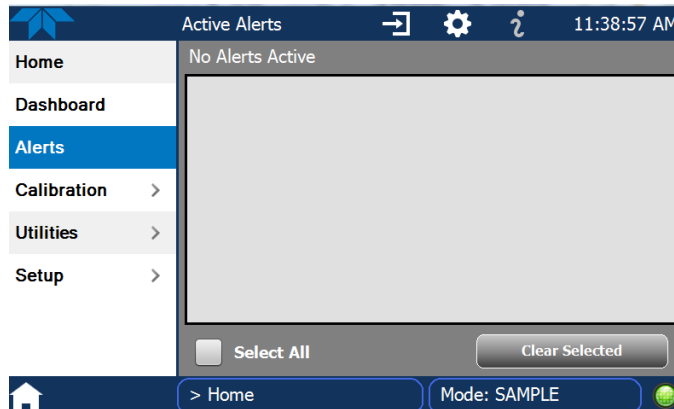

Figure 2-27. Active Alerts Cleared

Alerts and Events remain recorded in the Utilities>Alerts Log (Figure 2-28).

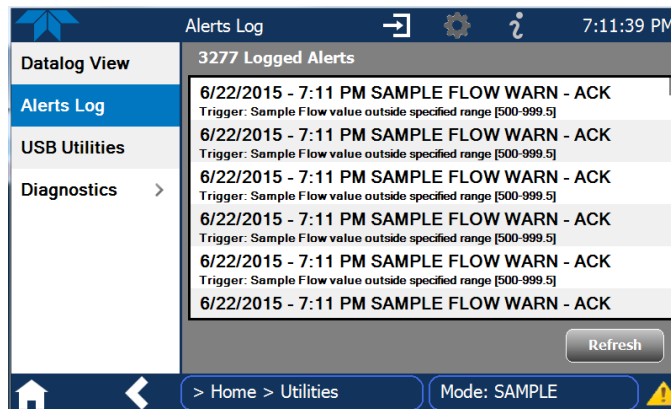

Figure 2-28. Utilities>Alerts Log of Active and Past Alerts and Events

2.4.4. CALIBRATION

The Calibration menu is used for zero/span/multipoint calibrations and for external calibration with valve options installed. Calibration procedures are presented in Section 4.

2.4.5. UTILITIES

The Utilities menu has a variety of functions as described next in Table 2-7.

Table 2-7. Utilities Submenu Descriptions

UTILITIES MENU	DESCRIPTION
Datalog View	Displays the data logs that were configured via the Setup>Data Logging menu. From this list a log can be selected and filters applied to view the desired data. (For details on setting up and running the Data Logger, see Section 2.5.1).
Alerts Log	Displays a history of alerts that are triggered by factory-defined and user-defined Events, such as warnings and alarms (See Section 2.5.2 for Events configuration).
USB Utilities	Serves multiple purposes using a flash drive connected to the instrument's front panel USB port: <ul style="list-style-type: none"> • download data from the instrument's Data Acquisition System (DAS), the Data Logger, to a flash drive (Section 2.5.1.3) • update firmware (Section 5.3) • transfer instrument configuration from/to other same-model instruments (Section 2.6) • download a basic operation functionality report (Section 5.3).
Diagnostics	Provides access to various pages that facilitate troubleshooting.
Analog Inputs	Measure voltage signals of several analog input parameters. These can be logged in the internal data acquisition system (DAS), by configuring the Data Logger in the Setup>Data Logging menu (Section 2.5.1).
Analog Outputs	Show the voltage signals for the functions selected and configured in the Setup>Analog Outputs menu (Section 2.5.8). Rear panel connections were presented in Section 2.3.1.2.
Digital Inputs	Show whether specific available features are turned ON or OFF; for example, whether or not Maintenance Mode input or Language selection can be controlled through the front panel, or whether a zero or span calibration can be activated remotely when an external source is connected to the rear panel Control In connector (Section 2.3.1.5).
Digital Outputs	Show the function of user-specified parameters configured in the Setup>Digital Outputs menu (Section 2.5.7).
Flow Cal	Used to calibrate the sample gas flow reading with actual flow measured by an external device. (See Section 5.6.10.3).
Ozone Flow Cal	Used to calibrate the ozone flow with actual flow measured by an external device. (See Section 5.6.10.3).
OE Test	Used to run either an electrical test (ETest) or an optics test (OTest) (Section 5.7.9.11).
O3 Gen Override	Used to override the Ozone Generator state when needed, such as for service (Section 5.7.9.15).

2.4.6. SETUP

The Setup menu is used to configure the instrument's various features, functions, and data log. Section 2.5 provides details for the menus under Setup.

2.5. SETUP MENU: FEATURES/FUNCTIONS CONFIGURATION

Use the Setup menu to configure the instrument’s software features, to gather information on the instrument’s performance, and to configure and access data from the Datalogger, the instrument’s internal data acquisition system (DAS). Once the setups are complete, the saved configurations can be downloaded to a USB drive through the Utilities>USB Utilities menu and uploaded to other instruments of the same model (Section 2.6).

2.5.1. SETUP>DATA LOGGING (DATA ACQUISITION SYSTEM, DAS)

The Datalogger can be configured to capture and store user-defined data, which then can be viewed in the Alerts page, if elected, as well as downloaded from the instrument to a USB flash drive or using NumaView™ Remote software for examination and analysis.

Figure 2-29 shows a new log; Figure 2-30 shows a sample existing log, which can be edited or deleted, and Figure 2-31 provides illustrated instructions for setting up a new log, with Sections 2.5.1.1 and 2.5.1.2 providing additional details.

To transfer captured instrument data to a flash drive see Section 2.5.1.3.

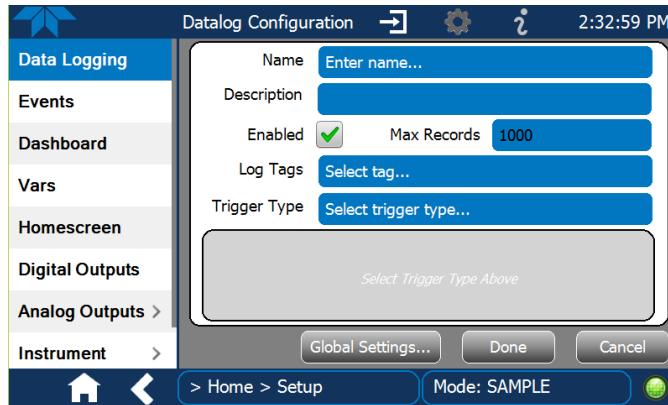

Figure 2-29. Datalog Configuration, New Log Page

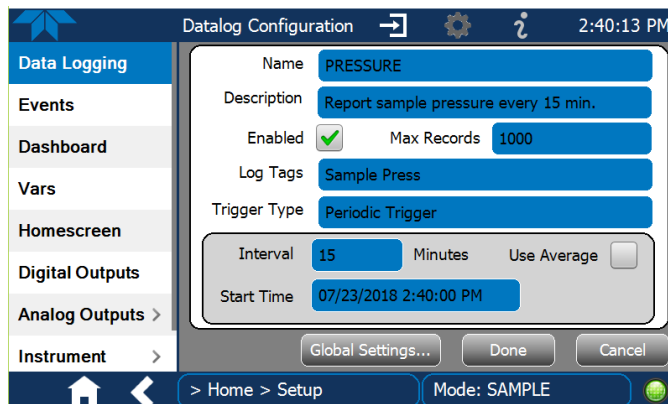

Figure 2-30. Datalog Configuration, Existing Log

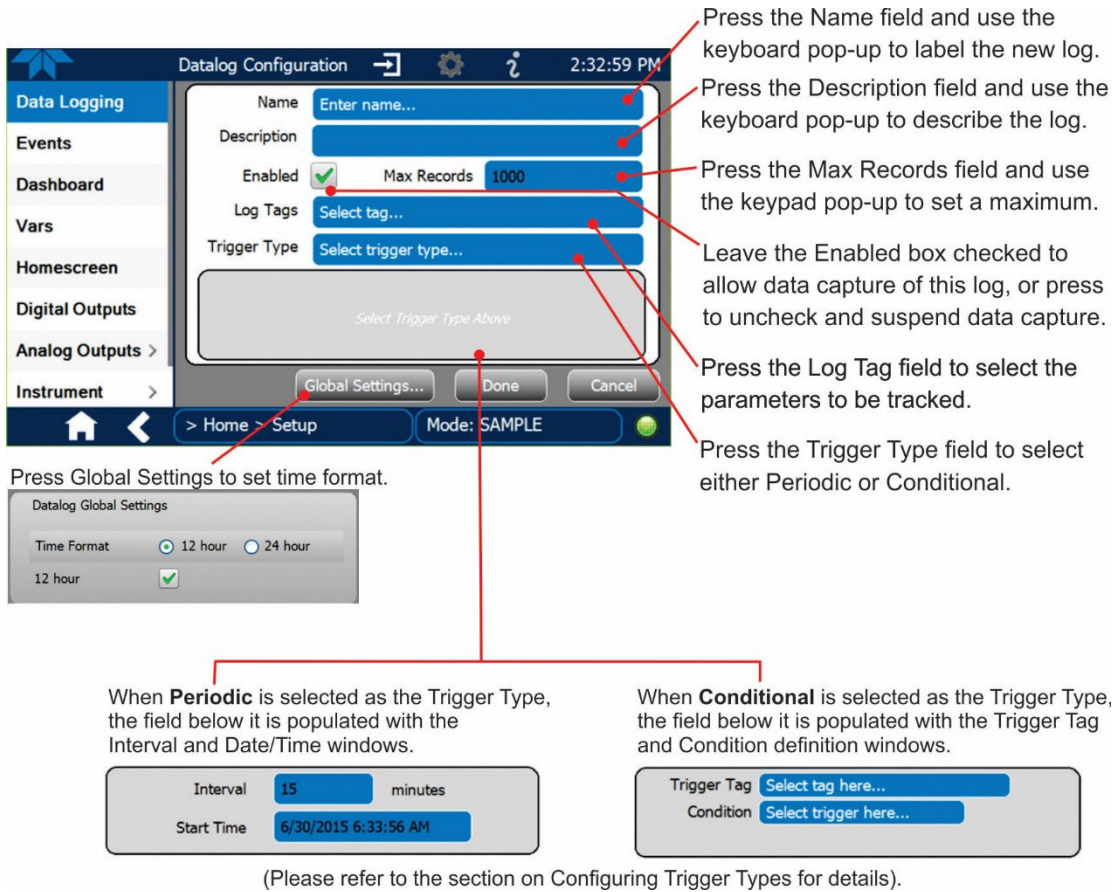
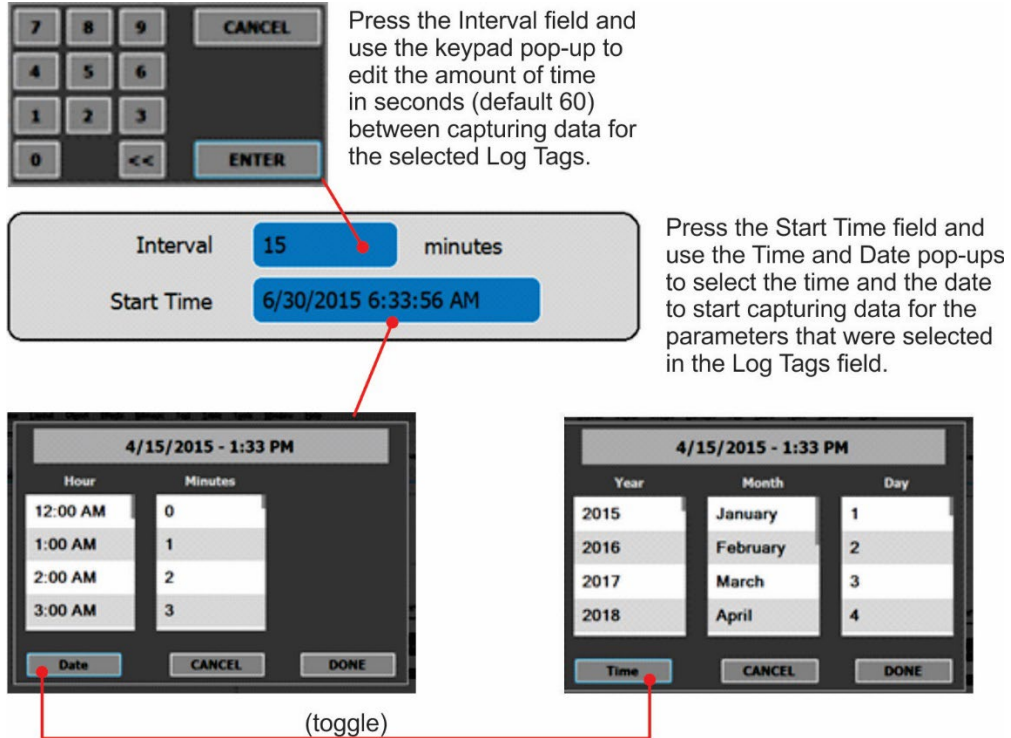

Figure 2-31. Creating a New Data Log

The parameters available in the list of Log Tags include the names of Events configured in the Events page (Section 2.5.2).

2.5.1.1. CONFIGURING TRIGGER TYPES: PERIODIC

The Periodic trigger is a timer-based trigger that is used to log data at a specific time interval. Periodic Trigger requires an interval that is set to number of minutes and a start time that is set to date and clock time.



Press the Interval field and use the keypad pop-up to edit the amount of time in seconds (default 60) between capturing data for the selected Log Tags.

Press the Start Time field and use the Time and Date pop-ups to select the time and the date to start capturing data for the parameters that were selected in the Log Tags field.

(toggle)

Figure 2-32. Datalog Periodic Trigger Configuration

2.5.1.2. CONFIGURING TRIGGER TYPES: CONDITIONAL

Conditional Trigger tracks/records data for user-selected parameters that meet specified conditions.

Press the Trigger Tag field and select a parameter to be tracked/logged. A default Condition associated with the selected Tag will populate the Condition field.

Press the Condition field to select a different choice from the condition list.

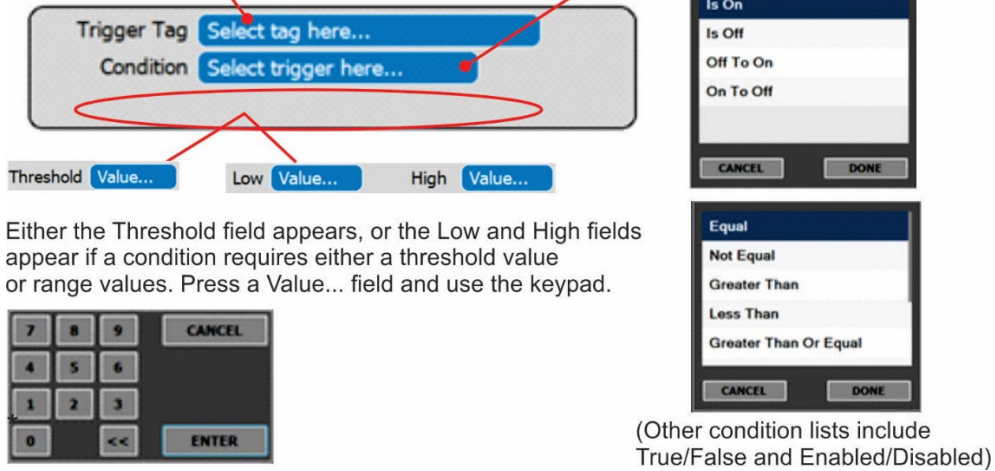

Either the Threshold field appears, or the Low and High fields appear if a condition requires either a threshold value or range values. Press a Value... field and use the keypad.

(Other condition lists include True/False and Enabled/Disabled)

Figure 2-33. Datalog - Conditional Trigger Configuration

2.5.1.3. DOWNLOADING DAS (DATA ACQUISITION SYSTEM) DATA

To download DAS data collected by the Datalogger from the instrument to a flash drive, navigate to the Utilities>USB Utilities>DAS Download menu.

1. Insert a flash drive into a front panel USB port and wait for the Status field to indicate that the drive has been detected; available buttons will be enabled.



Figure 2-34. DAS Download Page

2. Select all or define a period from which to download the collected data.
3. Press the Download button, and when complete, as indicated in the Status field, press the Done button (changed from “Cancel”) and remove the flash drive.

2.5.2. SETUP>EVENTS

Events are occurrences that relate to any operating function, and are used to define the conditions that can be set to trigger Alerts (Section 2.4.3). Events can provide diagnostic information about the instrument, typically referred to as “Warnings”, or they can provide other information on instrument functionality, such as concentration alarms. Some Events are standard and not editable while others are user-configurable, described here. Existing Events are listed in the Events page (Figure 2-35) under the Setup menu.

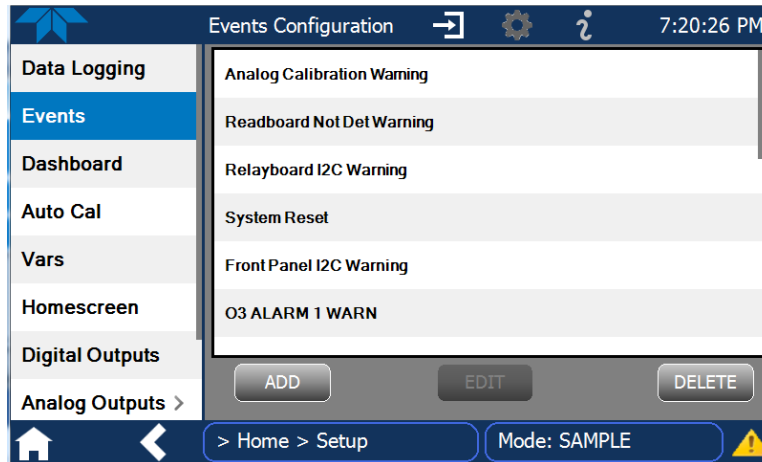

Figure 2-35. Events List

Access the Events Configuration page either from the Active Alerts page (Alerts Menu) by pressing the configuration button, or through the Home>Setup>Events menu (Figure 2-35). Press ADD to create a new Event (refer to Figure 2-36 for details), or select an existing Event to either Edit or Delete it (Figure 2-38).

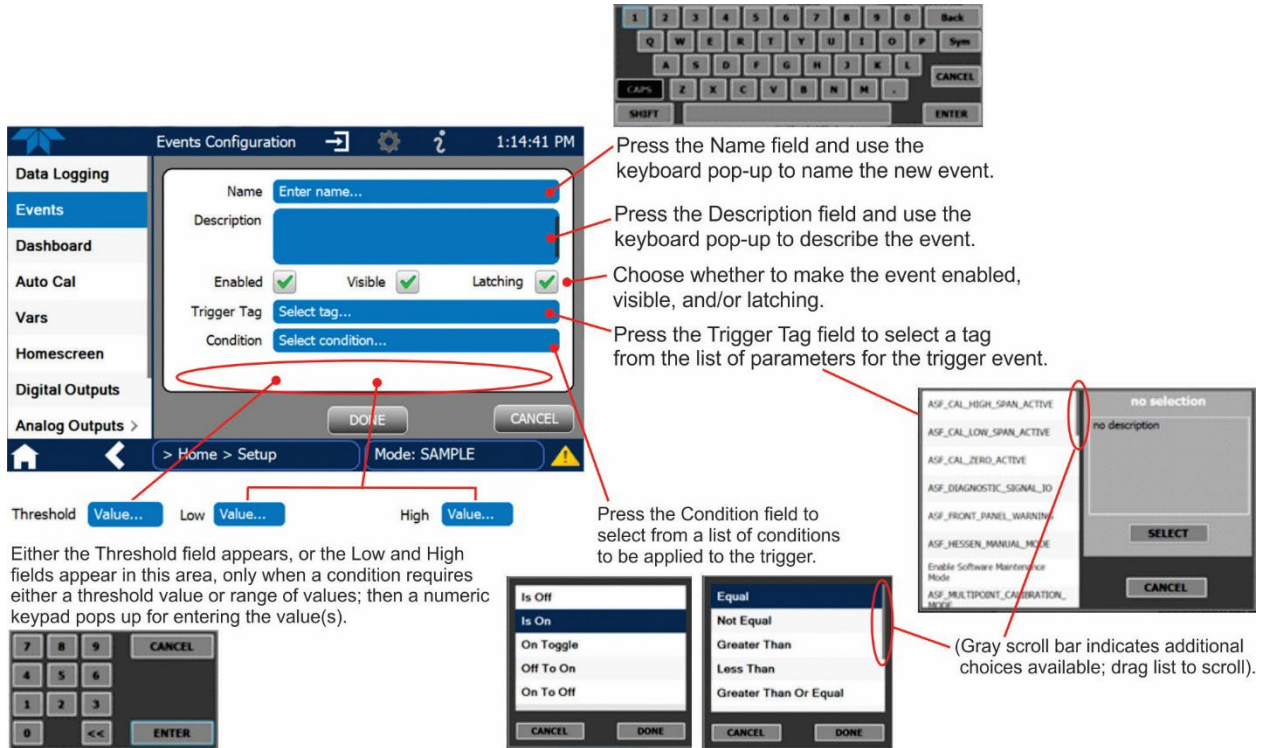

Figure 2-36. Event Configuration

- Enabled allows the choice of whether to track and record the Event (uncheck this box to “turn off” or deactivate the Event without deleting it). An Event must be enabled in order to use the Visible and the Latching options.
- Visible allows the choice of whether or not to display the Event in the Alerts page when it is triggered (it will still be recorded and can be viewed in the Utilities>Alerts Log). To use this option, the Event must be enabled.
- Latching allows the choice of whether or not to keep an Event visible even if the conditions that triggered it were to correct themselves. (Latching requires that the user interact with the Active Alerts screen to manually clear the Alert and internal Event state. Non-latching allows the entry in the Active Alerts screen and the internal Event state to continuously update based on the Event criteria, requiring no user interaction to clear the Alert or Event state).

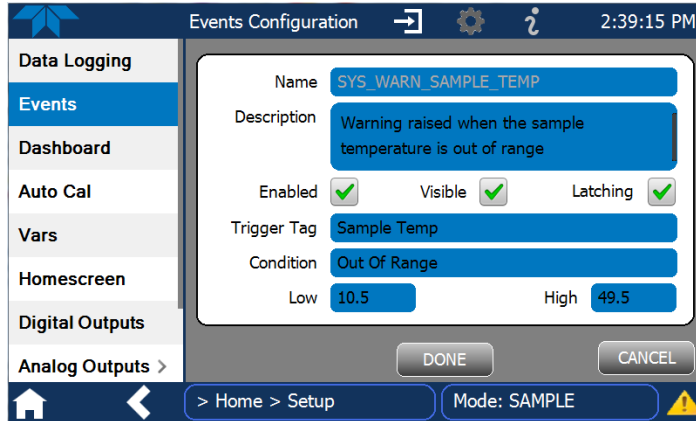

Figure 2-37. Configured Event Sample

2.5.2.1. EDITING OR DELETING EVENTS

Select an Event from the list (Figure 2-35) and press the Edit button to view or edit the details (Figure 2-37), or press the Delete button to delete the Event.

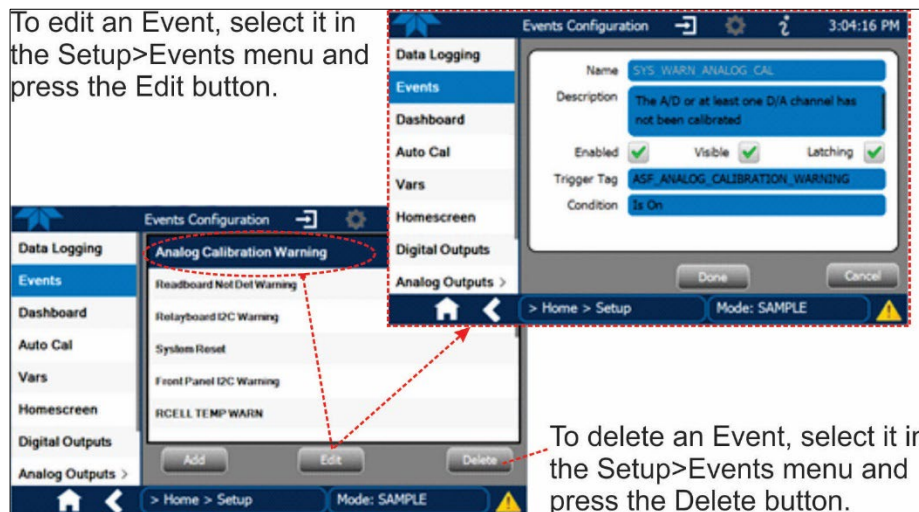

Figure 2-38. Edit or Delete an Event

2.5.2.2. USING EVENTS AS TRIGGERS FOR DATA LOGGING

Events can also be used to create customized triggers for data logging functions. The name entered in the Name field of the Events Configuration page will appear in the list of Log Tags of the Datalog Configuration page. The Data Logger is presented in Section 2.5.1.

2.5.3. SETUP>DASHBOARD

To navigate to Dashboard Configuration, either press the configuration shortcut in the Dashboard page, or use the Setup>Dashboard menu.

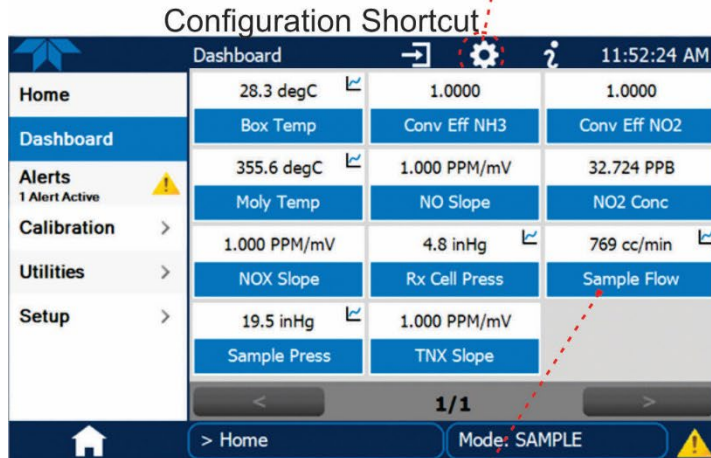

Configuration editing:

To add a parameter to the Dashboard, select it in the “Available Tags” list and press the right-pointing arrows button. (Checkmarks in the “Available Tags” list indicate parameters that are currently in the Dashboard).

To remove a parameter from the Dashboard, select it from the “Dashboard” list and press the left-pointing arrows button.

Select a graphable parameter in the Dashboard page to view a live plot.

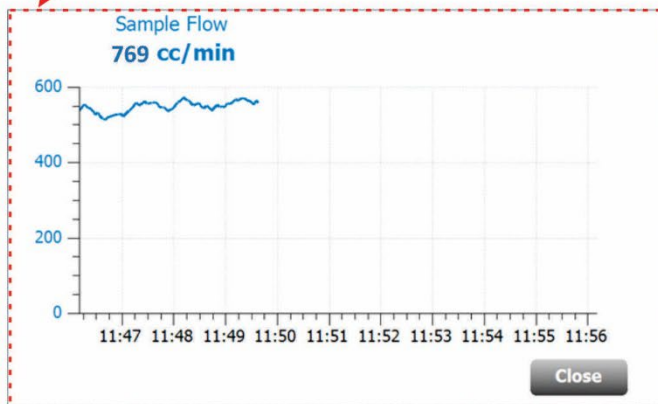

Figure 2-39. Dashboard Display and Configuration

2.5.4. SETUP>AUTO CAL (WITH VALVE OPTION)

Auto Cal is available with installed valve options (see Section 4.3).

2.5.5. SETUP>VARS

Vars are software variables that define operational parameters automatically set by the instrument's firmware, and are user-adjustable through this menu. Access the menu to see the list of variables; select a variable to view its description; touch the Edit button to change its setting(s).

Table 2-8. List of Variables with Descriptions

VARIABLE	DESCRIPTION
NOTE: This list includes several of the most common Vars; selecting any Var in the NumaView™ software interface will display its description in the information field to its right. Depending on configuration, some, all, or more of these variables appear in your instrument's Vars menu.	
Conc Precision (or PRIGAS/SECGAS Precision)	Sets the number of significant digits to the right of the decimal point display of concentration and stability values. ("PRIGAS" = primary gas with two or more other gases; "SECGAS" = secondary gas)
Daylight Savings Enable	Enable or disable Daylight Savings Time (also see Setup>Instrument>Date/Time Settings)
Dilution Factor Option	<p>Sets the instrument to compensate for diluted sample gas, such as in continuous emission monitoring (CEM) where the quality of gas in a smoke stack is being tested and the sampling method used to remove the gas from the stack dilutes the gas. Once the degree of dilution is known, this feature allows the user to add an appropriate scaling factor to the analyzer's concentration calculations so that the undiluted values for measurement range and concentration are shown on the instrument's front panel display and reported via the instrument's various outputs.</p> <ol style="list-style-type: none"> 1. Set the appropriate units of measure (Setup>Vars>User Units). 2. Select the reporting range mode (Setup>Vars>Range Mode) and set the reporting range upper limit (Setup>Analog Output). Ensure that the upper span limit entered for the reporting range is the maximum expected concentration of the undiluted gas. 3. Set the dilution factor as a gain, e.g., a value of 20 means 20 parts diluent and 1 part sample gas (Setup>Vars>Dilution Factor). 4. Calibrate the analyzer; ensure that the calibration span gas is either supplied through the same dilution system as the sample gas or has an appropriately lower actual concentration.
Dyn Zero Enable	Dynamic zero automatically adjusts offset and slope of the sample gas response when performing a zero point calibration during an AutoCal (Section 4.3).
Dynamic Span Enable	Dynamic span automatically adjusts the offsets and slopes of the sample gas response when performing a span point calibration during an AutoCal (Section 4.3).
Enable Software Maintenance Mode	Set instrument to continue sampling, while ignoring calibration, diagnostic, and reset instrument commands. This feature is of particular use for instruments connected to Multidrop (2.3.1.8) or Hessen protocol networks.

VARIABLE	DESCRIPTION
Instrument ID	Set unique identifier number for the instrument when it is connected with other instruments in multidrop configuration or on the same Ethernet LAN, or when applying MODBUS or Hessen protocols. (Setup>Vars>Instrument ID)
Max Concentration Range	Set the highest concentration expected, as this is used by the CPU to adjust Preamp physical ranges. (Section 4.1.6 provides more information).
Measure Mode	Selects the gases to measure, with a choice of either TN _x only or one of a few combinations: NO _x and NO, TN _x and NO, TN _x and NO _x , or all three.
Range Mode	Controls range mode, single (SNGL) or dual (DUAL). (When set to DUAL, ensure that Max Concentration Range has been set).
System Hours	Total system runtime hours
TPC Enable	Enables or disables the Temperature and Pressure Compensation (TPC) feature (For information on TPC, see Section 6.9.2).
User Units	Change the concentration units of measure.

2.5.6. SETUP>HOMESCREEN

To select a parameter (“tag”) for display in each of the three meters at the bottom of the Home page, navigate to the Homescreen configuration page through either the Setup>Homescreen menu or from Home page using the configuration icon (Figure 2-40).

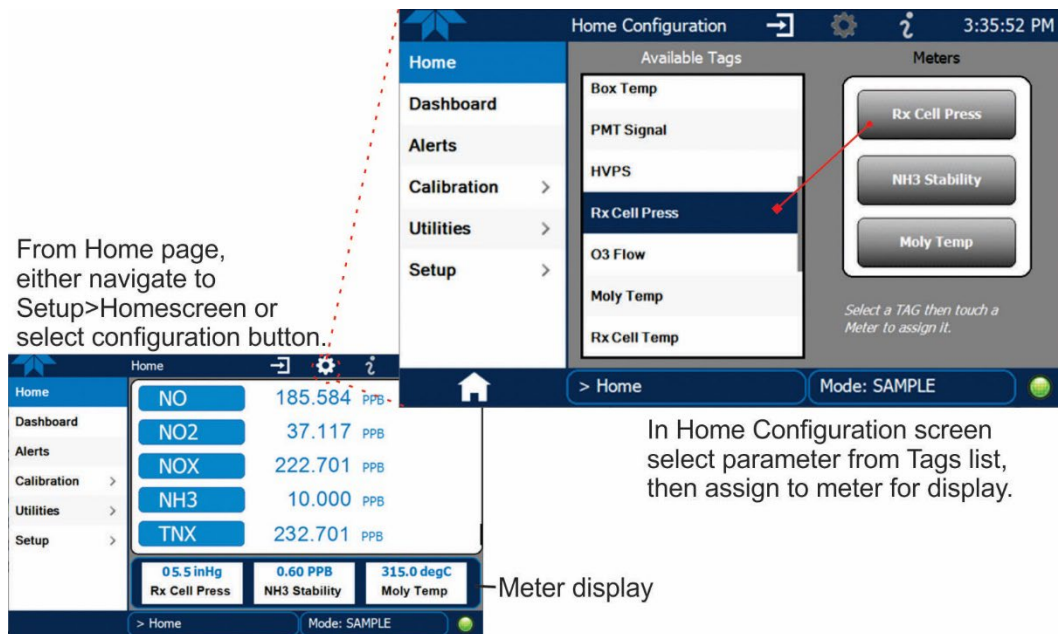

Figure 2-40. Homescreen Configuration

An orientation to the Homescreen was presented in Section 2.4.1, including Figure 2-23 and Figure 2-24.

2.5.7. SETUP>DIGITAL OUTPUTS

Specify the function of each digital output (connected through the rear panel STATUS connector) by mapping the output to a selection of “Signals” present in the instrument. Create custom “Signals” in the Setup>Events menu (Section 2.5.2). (If the Motherboard Relay Option was installed, the four additional relays can also be mapped).

To map Digital Outputs to Signals, select a pin in the Outputs list, then make a selection from the Signals list and press the Map button; if/as needed, change the polarity by pressing the Polarity button. Save any changes by pressing the Apply button, or discard the changes by pressing the Home or the back button (a pop-up provides a warning that the changes will be lost, and will prompt for confirmation to apply changes or not).

Go to the Utilities>Diagnostics>Digital Outputs menu to change the state (ON/OFF) of individual digital outputs.

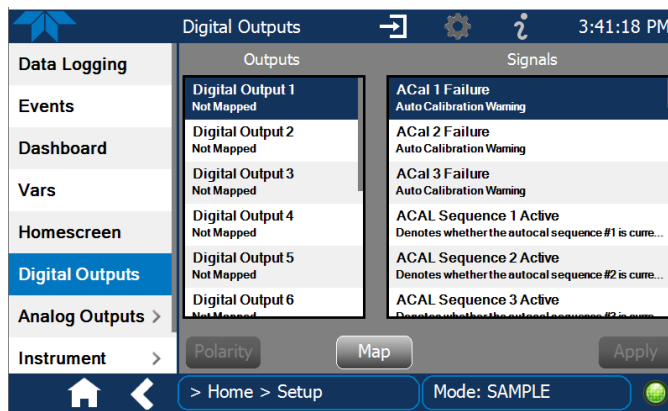

Figure 2-41. Digital Outputs Setup

2.5.8. SETUP>ANALOG OUTPUTS

Map the four user-configurable Analog Outputs to any of a wide variety of “Signals” present in the instrument and customize their respective configurations.

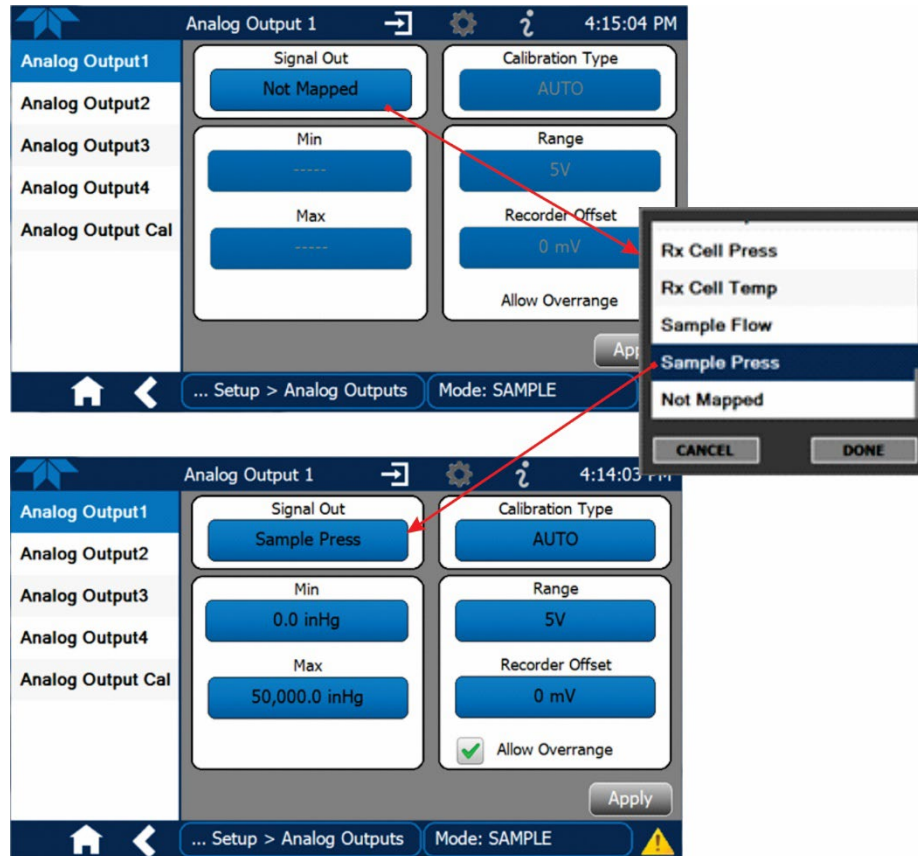

Figure 2-42. Analog Output Configuration Example

Refer to Figure 2-42 for the following:

- Signal Out: select a Signal for the output.
- Min/Max: edit minimum and maximum values associated with the selected Signal.
- Calibration Type:
 - AUTO for group calibration (Figure 2-43) of the analog outputs (cannot be selected when Current is selected for the Range)
 - MANUAL for individual calibration (Figure 2-44) of analog outputs where manual adjustments can be made (the only calibration type allowed when Current is selected for the Range). See Sections 2.5.8.1 and 2.5.8.2 .
- Range: assign a voltage or select Current (refer to Table 2-9).
- Recorder Offset: add a zero offset for recording slightly negative readings from noise around the zero point.
- Allow Overrange: check to allow a $\pm 5\%$ over-range; uncheck to disable over-range if the recording device is sensitive to excess voltage or current.

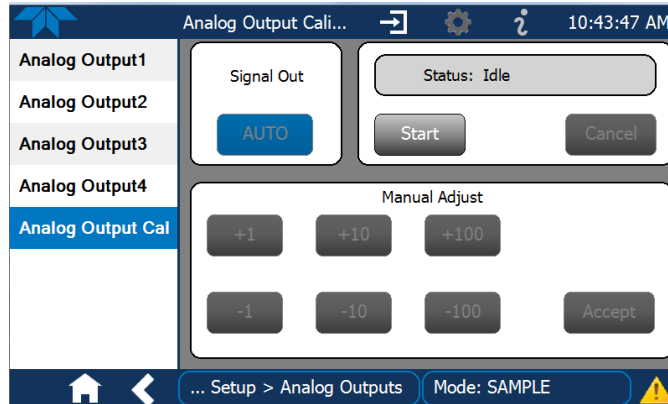

Figure 2-43. Analog Outputs Group Calibration Screen

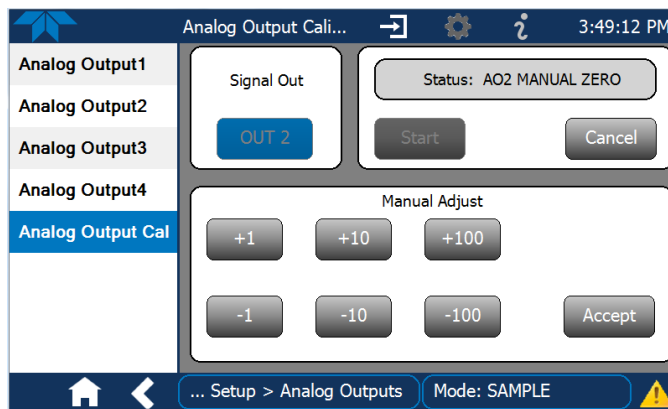

Figure 2-44. Analog Outputs Manual Calibration Screen (AOUT2 Example)

Table 2-9. Analog Output Voltage/Current Range

RANGE ¹	RANGE SPAN	MINIMUM OUTPUT	MAXIMUM OUTPUT
100mV	0-100 mVDC	-5 mVDC	105 mVDC
1V	0-1 VDC	-0.05 VDC	1.05 VDC
5V	0-5 VDC	-0.25 VDC	5.25 VDC
10V	0-10 VDC	-0.5 VDC	10.5 VDC
Current ²	0-20 mA	0 mA	20 mA

¹ Each range is usable from -5% to +5% of the rated span.

² While these are the physical limits of the current loop modules, typical applications use 2-20 mA or 4-20 mA for the lower and upper limits.

For manual calibration adjustments, see Section 2.5.8.1 for voltage and Section 2.5.8.2 for current.

2.5.8.1. MANUAL CALIBRATION OF VOLTAGE RANGE ANALOG OUTPUTS

It is possible to manually calibrate the voltages by using a voltmeter connected across the output terminals (Figure 2-45) and changing the output signal level in the Manual Adjust field of the Analog Outputs Calibration screen (Figure 2-44). Refer to Table 2-10 for voltage tolerances.

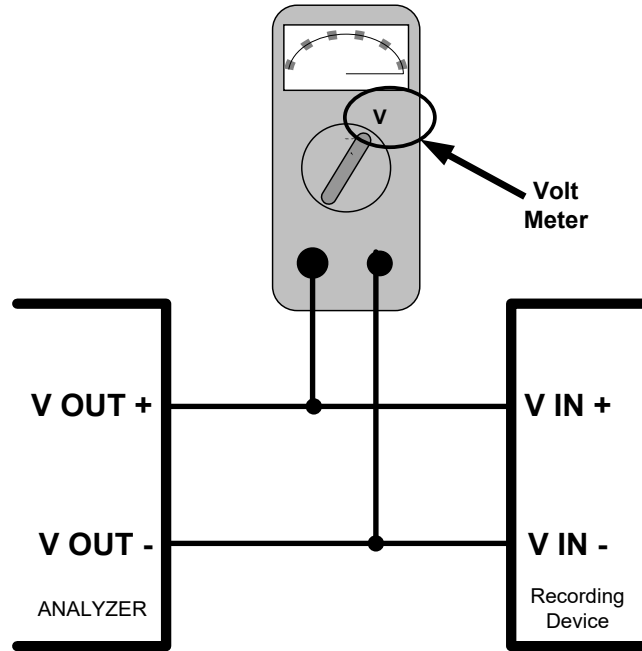

Figure 2-45. Setup for Checking / Calibrating DCV Analog Output Signal Levels

Table 2-10. Voltage Tolerances

FULL SCALE	ZERO TOLERANCE	SPAN VOLTAGE	SPAN TOLERANCE	MINIMUM ADJUSTMENT (1 count)
0.1 VDC	±0.0005V	90 mV	±0.001V	0.02 mV
1 VDC	±0.001V	900 mV	±0.001V	0.24 mV
5 VDC	±0.002V	4500 mV	±0.003V	1.22 mV
10 VDC	±0.004V	4500 mV	±0.006V	2.44 mV

2.5.8.2. MANUAL ADJUSTMENT OF CURRENT RANGE ANALOG OUTPUTS

These instructions assume that the Current Loop Option is installed (Section 2.3.1.3).

This option places circuitry in series with the output of the D-to-A converter on the motherboard that changes the normal DC voltage output to a 0-20 milliamp signal.

Adjusting the signal zero and span levels of the current loop output is done by raising or lowering the voltage output of the D-to-A converter circuitry on the analyzer's motherboard. This raises or lowers the signal level produced by the current loop option circuitry.

The software allows this adjustment to be made in 100, 10 or 1 count increments. Since the exact amount by which the current signal is changed per D-to-A count varies from output-to-output and instrument-to-instrument, you will need to measure the change in the signal levels with a separate, current meter placed in series with the output circuit. See Figure 2-6 for pin assignments and diagram of the analog output connector.



CAUTION!

Do not exceed 60 V peak voltage between current loop outputs and instrument ground.

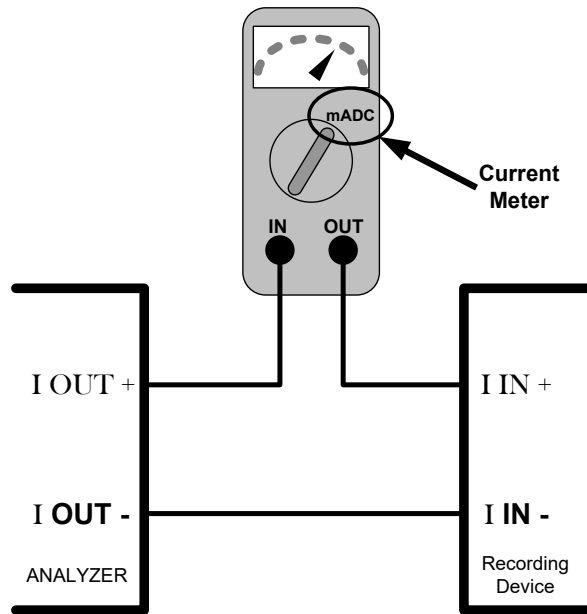

Figure 2-46. Setup for Checking / Calibration Current Output Signal Levels

An alternate method for measuring the output of the Current Loop converter is to connect a 250 ohm $\pm 1\%$ resistor across the current loop output in lieu of the current meter (see Figure 2-6 for pin assignments and diagram of the analog output connector). This allows the use of a voltmeter connected across the resistor to measure converter output as VDC or mVDC.

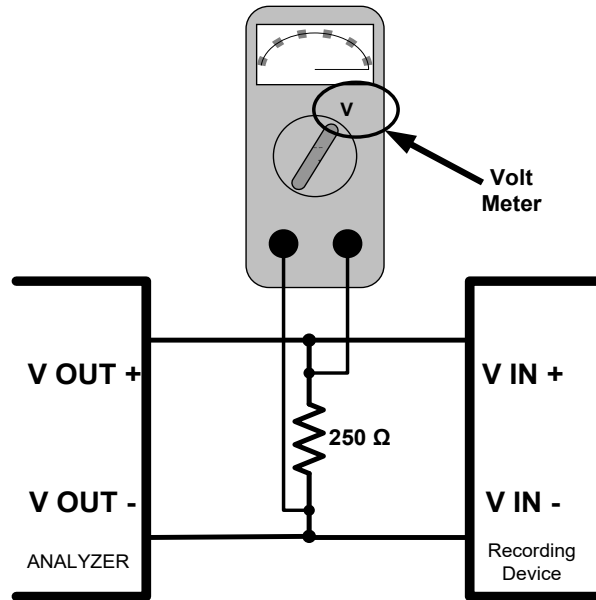

Figure 2-47. Alternative Setup Using 250Ω Resistor for Checking Current Output Signal Levels

In this case, follow the procedure above but adjust the output for the following values:

Table 2-11. Current Loop Output Check

% FS	Voltage across Resistor for 2-20 mA	Voltage across Resistor for 4-20 mA
0	500 mVDC	1000 mVDC
100	5000 mVDC	5000 mVDC

2.5.9. SETUP>INSTRUMENT

As presented in Table 2-12, view product and system information and network settings, edit network settings, and perform certain maintenance tasks.

Table 2-12. Setup>Instrument Menu

MENU	DESCRIPTION
Product Info	View Model, Part, and Serial Numbers and Package and Driver Versions, and options information.
System Info	View Windows and RAM information.
Network Settings	View the network settings (configurable through the Setup>Comm>Network Settings menu).
Date/Time Settings	Adjust date, hour, and minutes, select a time zone*, and set the system clock to automatically adjust for Daylight Savings Time or not. (Also see Setup>Vars>Daylight Savings Enable). *Time Zone change requires a special procedure; see Maintenance Section 5.5.
NTP Time Settings	Configure Network Time Protocol settings for clock synchronization.
Language	Select an available language.
Remote Update	When an instrument is connected to a network that is connected to the Internet, follow the instructions on this Remote Update page to check for and activate software/firmware updates. (Also refer to Section 5.3).

2.5.10. SETUP>COMM (COMMUNICATIONS)

This menu is for specifying the various communications configurations.

2.5.10.1. COM1/COM2

Configure the instrument's COM1 or COM2 ports to operate in modes listed in Table 2-13.

Table 2-13. COM1/COM2 Configuration

MODE	DESCRIPTION
Baud Rate	Set the baud rate for the COM1 or COM2 port being configured.
Command Prompt Display	Enable/disable a command prompt to be displayed when in terminal mode.
Data Bits	Set the data bits to 7 or 8 (typically set in conjunction with Parity and Stop bits).
Echo and Line Editing	Enable/disable character echoing and line editing.
Handshaking Mode	Choose SOFTWARE handshaking for data flow control (do NOT use SOFTWARE handshaking mode when using MODBUS RTU for Protocol mode; select only HARDWARE or OFF for MODBUS RTU), or HARDWARE for CTS/RTS style hardwired transmission handshaking. (This style of data transmission handshaking is commonly used with modems or terminal emulation protocols). Or choose to turn OFF handshaking.
Hardware Error Checking	Enable/disable hardware error checking.
Hardware FIFO	Enable/disable the hardware First In – First Out (FIFO) for improving data transfer rate for that COM port.
Modem Connection	Select either a modem connection or a direct cable connection.
Modem Init String	Input an initialization string to enable the modem to communicate.
Multidrop	Enable/disable multidrop mode for multi-instrument configuration on a single communications channel. Multidrop requires a unique ID for each instrument in the chain (Setup>Vars>Instrument ID).
Parity	Select odd, or even, or no parity (typically set in conjunction with Data Bits and Stop Bits).
Protocol	Select among the communications protocols: TAPI, Hessen, MODBUS RTU, or MODBUS ASCII (MODBUS: Section 3.5.1; Hessen: Section 3.5.2).
Quiet Mode	Enable/disable Quiet mode, which suppresses any feedback from the analyzer (such as warning messages) to the remote device and is typically used when the port is communicating with a computer program where such intermittent messages might cause communication problems. Such feedback is still available, but a command must be issued to receive them.
RS-485	Enable/disable the rear panel COM2 Port for RS-485 communication. RS-485 mode has precedence over Multidrop mode if both are enabled. Also, RS-485 configuration disables the rear panel USB port.
Security	Enable/disable the requirement for a password for this serial port to respond. The only command that is active is the request-for-help command (? CR).
Stop bits	Select either 0 or 1 stop bit (typically set in conjunction with Parity and Data bits).

2.5.10.2. TCP PORT1

TCP Port1 allows choosing whether or not to display the command prompt, editing the Port 1 number for defining the terminal control port by which terminal emulation software addresses the instrument, such as Internet or NumaView™ Remote software, and enabling or disabling security on this port.

2.5.10.3. TCP PORT2

TCP Port2 is configured with the port number for MODBUS.

2.5.10.4. TCP PORT3

TCP Port3 is configured with the port number for Hessen.

2.5.10.5. NETWORK SETTINGS

The Setup>Comm>Network Settings menu is for Ethernet configuration. The address settings default to automatic configuration by Dynamic Host Configuration Protocol (DHCP). Most users will want to configure the instrument with a static IP address: click the Static radio button to manually assign a static IP address (consult your network administrator, and see Table 2-14 for information).

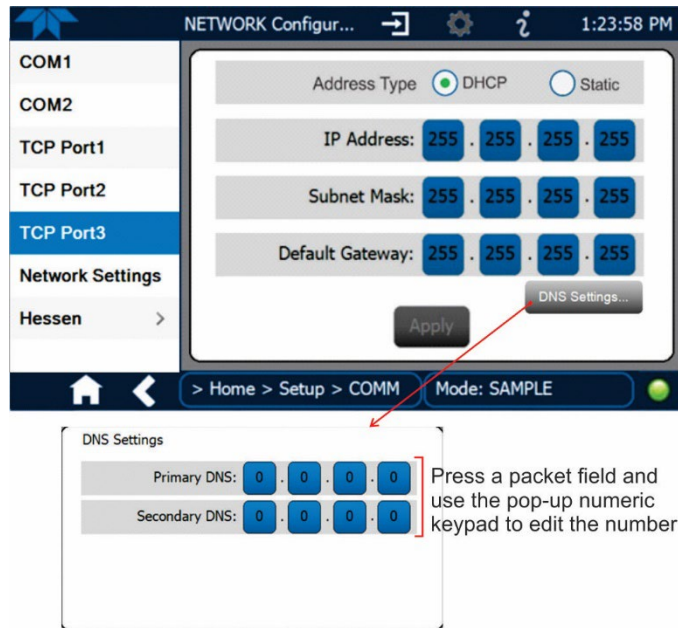

Figure 2-48. Communications Configuration, Network Settings

Table 2-14. LAN/Ethernet Configuration Properties

PROPERTY	DESCRIPTION
IP address	A string of four packets of 1 to 3 numbers each (e.g. 192.168.76.55.) is the internet protocol address of the instrument itself.
Subnet Mask	A string of four packets of 1 to 3 numbers each (e.g. 255.255.252.0) number that masks an IP address, and divides the IP address into network address and host address and identifies the LAN to which the device is connected. All addressable devices and computers on a LAN must have the same subnet mask. Any transmissions sent to devices with different subnets are assumed to be outside of the LAN and are routed through the gateway computer onto the Internet.
Default Gateway	A string of numbers very similar to the Instrument IP address (e.g. 192.168.76.1.) that is the address of the computer used by your LAN and serves as a router to access the Internet or another network.

2.6. TRANSFERRING CONFIGURATION TO OTHER INSTRUMENTS

Once an instrument is configured, the same configuration can be copied to other instruments of the same Model. This encompasses essentially anything the user can configure and does not apply to instrument-specific settings such as those that are configured at the factory for calibration.

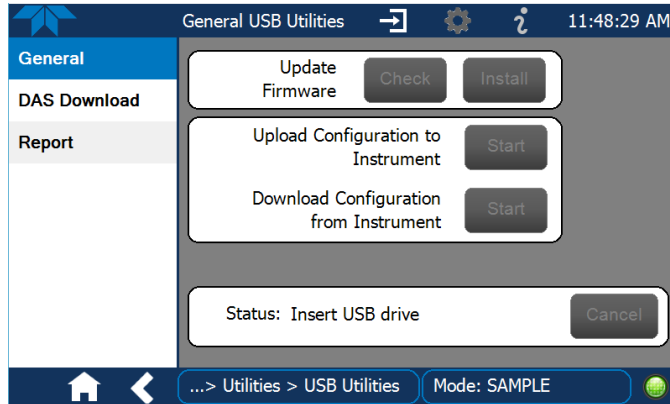

Figure 2-49. Configuration Transfer

1. In the source instrument, go to the Home>Utilities>USB Utilities>General page.
2. Insert a flash drive into either of the two front panel USB ports.
3. When the Status field indicates that the USB drive has been detected, press the “Download Configuration from Instrument” Start button.
4. When the Status field indicates that the download is complete, remove the flash drive.
5. In the target instrument, go to the Home>Utilities>USB Utilities>General page.
6. Insert a flash drive into either of the two front panel USB ports.
7. When the Status field indicates that the USB drive has been detected, press the “Upload Configuration to Instrument” Start button.
8. When the Status field indicates that the upload is complete, remove the flash drive.

3. COMMUNICATIONS AND REMOTE OPERATION

This instrument's rear panel connections include an Ethernet port, a USB port (option) and two serial communications ports labeled RS232, which is the COM1 port in the software menu, and COM2 (refer to Figure 2-2). These ports allow the ability to communicate with, issue commands to, and receive data from the analyzer through an external computer system or terminal. Connection instructions were provided in Section 2.3.1.8. Configuration information was provided in Section 2.5.10.

This Section provides pertinent information regarding communication equipment, the communications ports, and communications protocol. Data acquisition is set up through the Datalogger (Section 2.5.1).

3.1. DATA TERMINAL/COMMUNICATION EQUIPMENT (DTE DCE)

RS-232 was developed for allowing communications between data terminal equipment (DTE) and data communication equipment (DCE). Basic terminals always fall into the DTE category whereas modems are always considered DCE devices. The difference between the two is the pin assignment of the Data Receive and Data Transmit functions.

- DTE devices receive data on pin 2 and transmit data on pin 3.
- DCE devices receive data on pin 3 and transmit data on pin 2.

To allow the analyzer to be used with terminals (DTE), modems (DCE) and computers (which can be either), a switch mounted below the serial ports on the rear panel, labeled DCE DTE (Figure 2-2), allows the user to set the RS-232 configuration for one of these two data devices. This switch exchanges the Receive and Transmit lines on RS-232 emulating a cross-over or null-modem cable. The switch has no effect on COM2.

3.2. SERIAL COMMUNICATION

Referring to Table 2-13, use the SETUP>COMM menu to configure COM1 (labeled RS232 on instrument rear panel) and/or COM2 (labeled COM2 on instrument rear panel) for communication modes, baud rate and serial communications. If using a USB option communication connection, setup requires that the instrument's baud rate and personal computer baud rate match.

3.2.1. SERIAL COMMUNICATION: RS-232

The RS232 and COM2 communications ports operate on the RS-232 protocol (default configuration). Configurations possible for these two ports are:

- RS232 port can also be configured to operate in single or RS-232 Multidrop mode (Option 62); refer to Section 2.3.1.8.
- COM2 port can be left in its default configuration for standard RS-232 operation including multidrop, or it can be reconfigured for half-duplex RS-485 operation (please contact the factory for this configuration).

Note

When the rear panel COM2 port is in use, except for multidrop communication, the rear panel USB port cannot be used. (Alternatively, when the USB port is enabled, COM2 port cannot be used except for multidrop).

A code-activated switch (CAS), can also be used on either port to connect typically between 2 and 16 send/receive instruments (host computer(s) printers, data loggers, analyzers, monitors, calibrators, etc.) into one communications hub. Contact Teledyne API Sales (front cover, this manual) for more information on CAS systems.

3.2.2. SERIAL COMMUNICATION: RS-485 (OPTION)

The COM2 port of the instrument’s rear panel is set up for RS-232 communication but can be reconfigured for RS-485 communication. Contact Technical Support for reconfiguration unless this option was elected at the time of purchase, then the rear panel was preconfigured at the factory.

3.3. ETHERNET

When using the Ethernet interface, the analyzer can be connected to any standard 10BaseT or 100BaseT Ethernet network via low-cost network hubs, switches or routers. The interface operates as a standard TCP/IP device on port 3000. This allows a remote computer to connect through the network to the analyzer using NumaView™ Remote, terminal emulators or other programs.

The Ethernet connector has two LEDs that are on the connector itself, indicating its current operating status.

Table 3-1. Ethernet Status Indicators

LED	FUNCTION
amber (link)	On when connection to the LAN is valid.
green (activity)	Flickers during any activity on the LAN.

The analyzer is shipped with DHCP enabled by default. This allows the instrument to be connected to a network or router with a DHCP server; however, it should be configured with a Static IP address as soon as practical. See Section 2.5.10.5 for configuration details.

3.4. NUMAVIEW™ REMOTE

For remote operation and data capture through an Ethernet connection, please refer to the NumaView™ Remote Software User Guide, PN 08492, available on our website.

3.5. COMMUNICATIONS PROTOCOLS

MODBUS (Section 3.5.1) and Hessen (Section 3.5.2) are available with the analyzer. MODBUS registers are provided in Appendix A.

3.5.1. MODBUS

These instructions assume that the user is familiar with MODBUS communications, and provide minimal information to get started. Please refer to the Teledyne API MODBUS manual, PN 06276, and to www.modbus.org for MODBUS communication protocols.

Minimum Requirements:

- Instrument firmware with MODBUS capabilities installed
- MODBUS-compatible software (TAPI uses MODBUS Poll for testing; see www.modbustools.com)
- Personal computer with communications cable (Ethernet or USB or RS232), and possibly a null modem adapter or cable

3.5.1.1. MODBUS COM PORT CONFIGURATION

MODBUS communications can be configured for transmission over Ethernet or serial COM port through the Setup>Comm menu. Make the appropriate cable connections (Ethernet or COM port) between the instrument and a PC.

Check the instrument’s Modbus Units selection in the Setup>Vars menu and edit if needed.

Ethernet: MODBUS is available on TCP port 502. By default, port 502 is assigned to the instrument’s TCP Port 2. (Setup>Comm> TCP Port2, Figure 3-1).

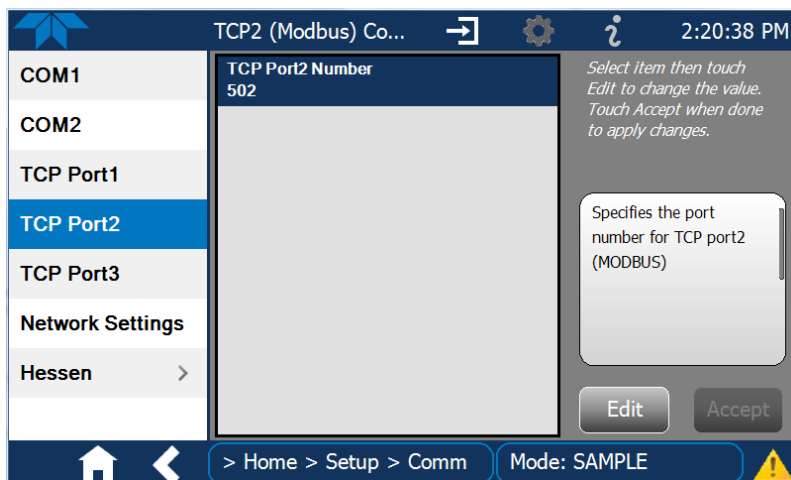

Figure 3-1. MODBUS via Ethernet

Serial COM: Both COM1 (labeled “RS232” on the instrument’s rear panel) and COM2 are configurable for RS-232 or RS-485 communication with either MODBUS RTU or MODBUS ASCII transmission modes. In the Setup>Comm COM1[COM2] menu, edit the Protocol parameter to select a MODBUS transmission mode; edit Baud Rate, Parity, Data Bits, etc., if necessary (see descriptions in Table 2-13).

Important When using MODBUS RTU, ensure that the COM1[COM2] Handshaking Mode is set to either Hardware or OFF. Do NOT set it to Software.

Press the Accept button to apply the settings. (Figure 3-2 shows an example for MODBUS RTU).

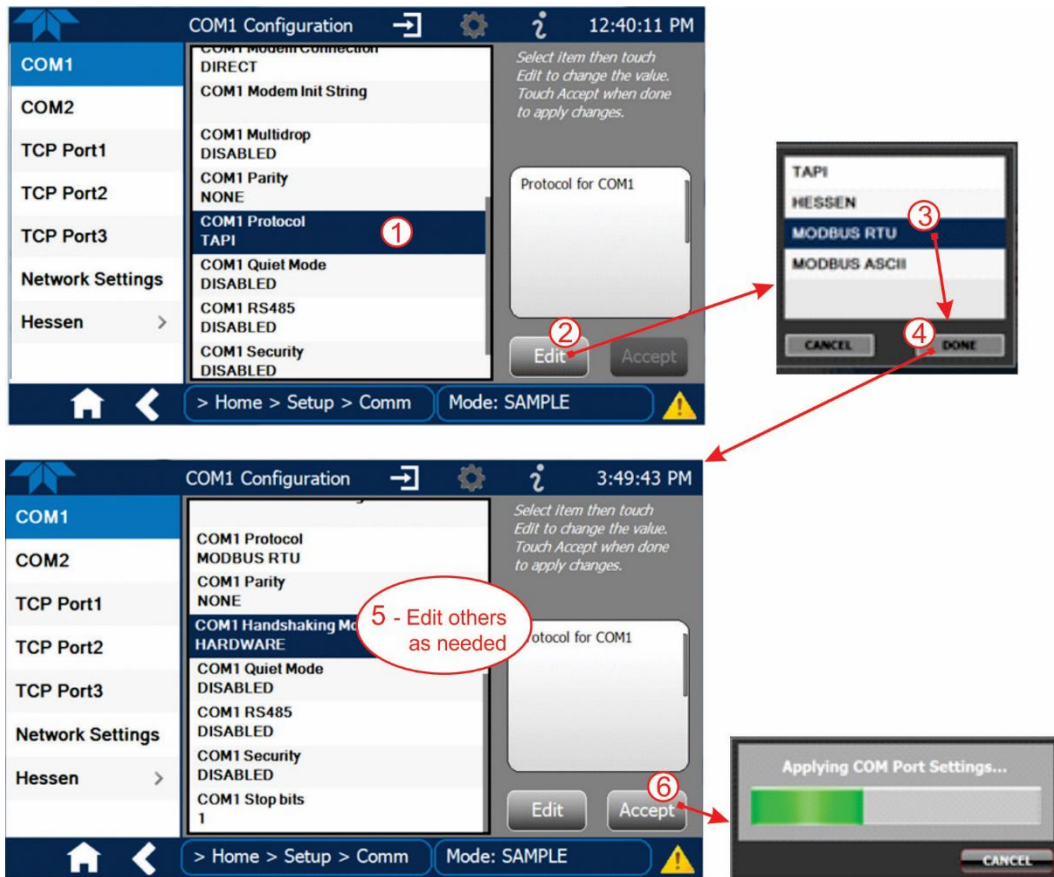

Figure 3-2. MODBUS via Serial Communication (example)

Important When more than one analyzer is connected to the network, create a unique identification number for each in the Setup>Vars>Instrument ID menu.

Next, for the settings to take effect, power off the analyzer, wait 5 seconds, and power it on again.

3.5.2. HESSEN

Hessen is a multidrop protocol, in which several remote instruments (slaves) are connected via a common communications channel to a host computer. Slaves respond only to commands sent by the host using their unique identification.

Important Create a unique identification number for each instrument in the multidrop chain via the Setup>Vars>Instrument ID menu.

The Hessen protocol is not strictly defined; therefore, while Teledyne API's application is completely compatible with the protocol itself, it may be different from implementations by other companies.

3.5.2.1. HESSEN COM PORT CONFIGURATION

Configure the COM1/COM2 port for Hessen protocol through the Setup>Comm>COM1[COM2] menu: select COM1[COM2] Protocol and press Edit to select HESSEN, then press Accept.

Ensure that the communication parameters of the host computer are also properly set.

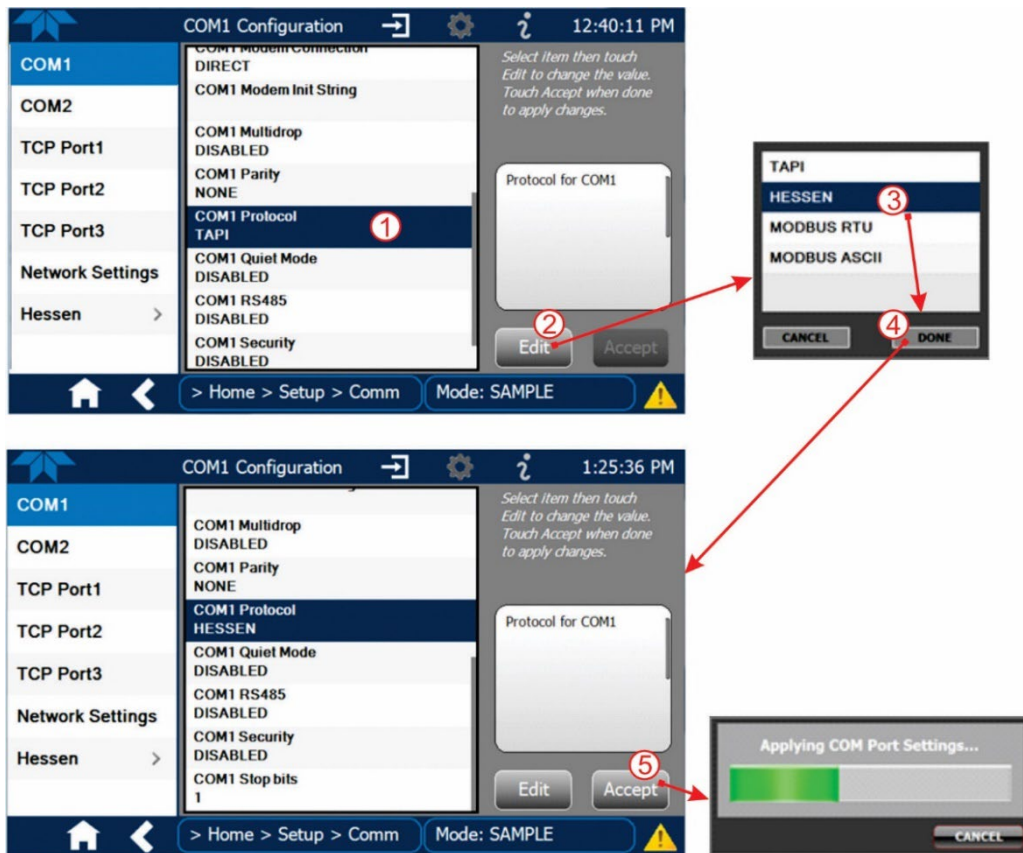

Figure 3-3. Serial Communication, Setting Hessen Protocol

Note The instrument software has a 200 ms latency period before it responds to commands issued by the host computer. This latency should present no problems, but be mindful of issuing commands to the instrument too frequently.

3.5.2.2. HESSEN SETTINGS CONFIGURATION

Hessen configuration includes settings for alarms, version, response mode, status flags and gas list. Locate the alarms in the Hessen Settings list (Setup>Comm>Hessen>Hessen Settings) and edit as desired.

HESSEN VARIATION

For the Hessen Variation setting, there are two versions.

- TYPE 1 is the original implementation.
- TYPE 2 has more flexibility when operating with instruments that can measure more than one type of gas. For more specific information about the difference between the two versions, download the *Manual Addendum for Hessen Protocol* from the Teledyne API's web site: <http://www.teledyne-api.com/manuals/>.

HESSEN PROTOCOL RESPONSE MODE

Set the response mode under Hessen Response Mode, referring to Table 3-2 for descriptions.

Table 3-2. Teledyne API's Hessen Protocol Response Modes

MODE ID	MODE DESCRIPTION
CMD	This is the default setting. Responses from the instrument are encoded as the traditional command format. Style and format of responses depend on exact coding of the initiating command.
BCC	Responses from the instrument are always delimited with <STX> (at the beginning of the response, <ETX> (at the end of the response followed by a 2 digit Block Check Code (checksum), regardless of the command encoding.
TEXT	Responses from the instrument are always delimited with <CR> at the beginning and the end of the string, regardless of the command encoding.

HESSEN STATUS FLAGS

Locate the various status flags in the Hessen Settings list and edit as needed. They are listed by status flag name with their default bit assignments. (Those with unassigned flags are listed as "0x0000").

- The status bits are included in the instrument's responses to inform the host computer of its condition. Each bit can be assigned to one operational and warning message flag.
- It is possible to assign more than one flag to the same Hessen status bit. This allows the grouping of similar flags, such as all temperature warnings, under the same status bit.
- Assigning conflicting flags to the same bit will cause each status bit to be triggered if any of the assigned flags is active.

Table 3-3. Hessen Status Flags and Default Bit Assignments

STATUS FLAG NAME ³	DEFAULT BIT ASSIGNMENT (USER EDITABLE; ALSO SEE NOTE ³)
WARNING FLAGS	
SAMPLE FLOW WARNING	0001
OZONE FLOW WARNING	0002
RCEL PRESS WARNING	0004
BOX TEMP WARNING	0008
RCELL TEMP WARNING	0010
IZS TEMP WARNING ¹	0020
PMT TEMP WARN	0040
CONV TEMP WARNING	0080
INVALID CONC	8000
OPERATIONAL FLAGS	
In MANUAL Calibration Mode	0200
In ZERO Calibration Mode	0400
In SPAN Calibration Mode	0800
In WARMUP Mode	1000
UNITS OF MEASURE FLAGS	
UGM	0000
MGM	2000
PPB	4000
PPM	6000
SPARE/UNUSED BITS	0100
UNASSIGNED FLAGS (0000)	
MANIFOLD TEMPERATURE ²	HVPS WARNING
OZONE GEN OFF	FRONT PANEL WARN
SYSTEM RESET	ANALOG CAL WARNING
RELAY BOARD WARNING	CANNOT DYN ZERO
REAR BOARD NOT DETECTED	CANNOT DYN SPAN
AUTOZERO WARNING	Instrument is in MP CAL mode

¹ Only applicable if the optional internal span gas generator is installed.

² Only applicable if the analyzer is equipped with an oxygenator option.

³ It is possible to assign more than one flag to the same Hessen status bit. This allows the grouping of similar flags, such as all temperature warnings, under the same status bit.

Be careful not to assign conflicting flags to the same bit as each status bit will be triggered if any of the assigned flags is active.

3.5.2.3. HESSEN GAS LIST CONFIGURATION

Configure the Hessen Gas List in the Setup>Comm>Hessen>Hessen Gas List page. Choose the Gas, the concentration Range, and enter the gas ID. Refer to and to the Table below.

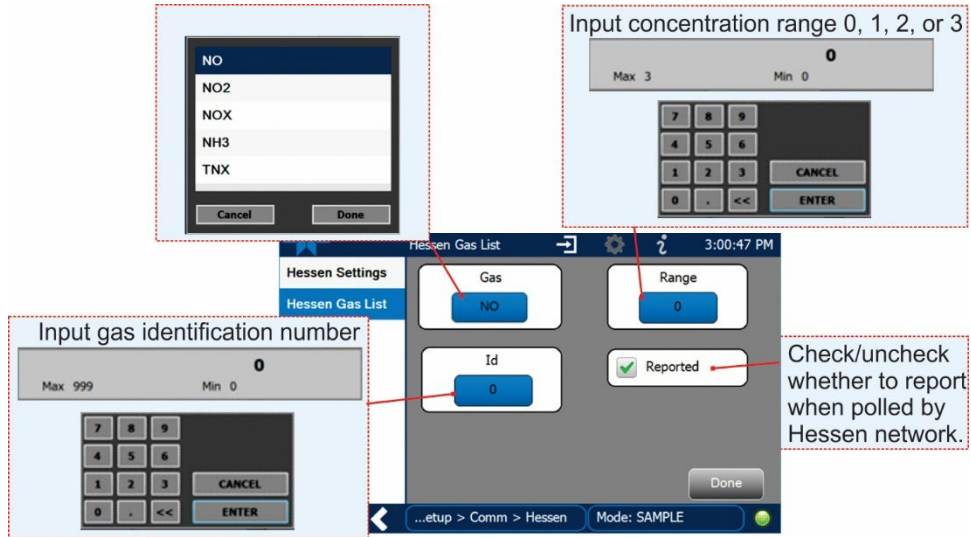

Menu: Setup>Comm>Hessen>Hessen Settings>Hessen Gas List

Figure 3-4. Hessen Gas List Configuration

Table 3-4. Hessen Gas List Definitions

PARAMETER	DEFINITION
Gas	type of gas to be reported
Range	concentration range to be reported (when Reported box is checked)
0	currently active range
1	only when range 1 or low range is active
2	only when range 2 or high range is active
3	Not Applicable
Id	specific gas identification
(user definable)	NO _x
(user definable)	NO
(user definable)	NO ₂
(user definable)	TN _x
Reported	choice of whether to report when polled by the Hessen network

4. CALIBRATION

The T201 measures different levels of nitric oxide sample gas on three separate channels (TN_x, NO_x, NO). The ammonia and nitrogen dioxide concentrations are then calculated using this information.

This Section is organized into subsections as follows:

SECTION 4.1 – Important Precalibration Information: contains important information you should know before calibrating the instrument.

SECTION 4.2 – Calibration Procedures: describes the procedure for manually checking calibration and performing actual calibration of the instrument.

SECTION 4.3 – Automatic Zero/Span Cal/Check (Auto Cal): describes the procedure for using the AutoCal feature to check calibration or to calibrate the instrument. (The AutoCal feature requires that either the zero/span valve option or the internal span gas generator option be installed and operating).

SECTION 4.4 – Calibration Quality Analysis: describes how to evaluate quality of each calibration.

SECTION 4.5 – NO₂ Conversion Efficiency (CE): provides information on monitoring and calibrating the efficiency of the converter.

4.1. IMPORTANT PRECALIBRATION INFORMATION

IMPORTANT DO NOT pressurize the sample, span or zero ports (Zero/Span valves are optional) during calibration. Allow the analyzer to pull the gas through the system using the vacuum pump.

Note A start-up period of 4-5 hours is recommended prior to calibrating the analyzer.

4.1.1. LEAK CHECK

Always perform a leak check prior to calibration.

4.1.2. CALIBRATION REQUIREMENTS

The following equipment, supplies, and expendables are required for calibration:

- Zero-air source
- Span gas source
- Gas line materials that comply with the information provided in Section 2.3.2.1.

Optional equipment: A recording device such as a strip-chart recorder and/or data logger.

For electronic documentation, the internal data acquisition system (DAS) can be used by configuring the Datalogger through the Setup>Data Logging menu; Section 2.5.1).

- See Section 4.2.1 for instructions for initial calibration of the analyzer in its base configuration.
- See Section 4.2.2 for information regarding setup and calibration of the analyzer with Z/S Valve options.

Note

Zero air and span gases must be supplied at twice the instrument's specified gas flow rate. Therefore, the zero and span gases should be supplied to their respective inlets in excess of 2000 cc/min (1000 cc/min x 2).

4.1.3. ZERO AIR

Zero air or zero calibration gas is similar in chemical composition to the measured medium but without the gas to be measured by the analyzer. This means zero air should be devoid of NO, NO₂, CO₂, NH₃ or H₂O vapor.

Note

Moderate amounts of NH₃ and H₂O can be removed from the sample gas stream by sample gas dryer/scrubber.

- If your application is not a measurement in ambient air, the zero calibration gas should be matched to the composition of the gas being measured.
- Pure nitrogen (N₂) could be used as a zero gas for applications where NO_x is measured in nitrogen.
- If your analyzer is equipped with an external zero air scrubber option, it is capable of creating zero air from ambient air.
- For analyzers without the external zero air scrubber, a zero air generator such as the Teledyne API's Model T701 can be used. Please visit the company website for more information.

4.1.4. CALIBRATION (SPAN) GAS

Calibration gas is specifically mixed to match the chemical composition of the type of gas being measured at near full scale of the desired reporting range. Before spanning the analyzer, it is good practice to observe the Normalized PMT signal: its value should be equal to twice the concentration of the delivered span gas. A common error made during calibration is to span the analyzer with either too low a gas concentration or an incorrect value entered for the TN_x or NO_x concentrations. Commonly this will cause a slope value much greater than 1.0.

To measure NO_x with the analyzer, it is recommended that you use a span gas with an NO concentration equal to 80% of the measurement range for your application. To measure ammonia, it is recommended that you use a span gas of bottled ammonia gas diluted to a level set to 80% of the expected sample range.

Note

The first time bottled ammonia is connected to the gas dilution system, regulator/calibrator, the TN_x reading may take a number of hours to stabilize.

EXAMPLE:

- If the application is to measure NO_x in ambient air between 0 ppb and 500 ppb, an appropriate span gas would be 400 ppb.
- If the application is to measure NO_x in ambient air between 0 ppb and 1000 ppb, an appropriate span gas would be 800 ppb.

4.1.5. SPAN GAS FOR MULTIPOINT CALIBRATION

Some applications, such as EPA monitoring, require a multipoint calibration where span gases of different concentrations are needed. We recommend using an NO gas of higher concentration combined with a gas dilution calibrator that does not include Teflon tubing or internal MFC's, which can be affected by ammonia gas. Calibrators mix high concentration gas with zero air to accurately produce span gas of the desired concentration. Linearity profiles can be automated with these models and run unattended overnight.

If a dynamic dilution system is used to dilute high concentration gas standards to low, ambient concentrations, ensure that the NO concentration of the reference gas matches the dilution range of the calibrator. (Section 2.5.5 contains information about the dilution option).

Choose the NO gas concentration so that the dynamic dilution system operates in its mid-range and not at the extremes of its dilution capabilities.

EXAMPLE:

- A dilution calibrator with 10-10000 dilution ratio will not be able to accurately dilute a 5000 ppm NO gas to a final concentration of 500 ppb, as this would operate at the very extreme dilution setting.
- A 100 ppm NO gas in nitrogen is much more suitable to calibrate the analyzer (dilution ratio of 222, in the mid-range of the system's capabilities).

4.1.6. PHYSICAL RANGE MEASUREMENTS

The measurement physical ranges for NH₃, TN_x, NO_x, NO and NO₂ concentrations are 0-50 ppb (low range) or 0-2,000 ppb (high range).

Electronically the analyzer converts the 0-5 volt analog signal output from the PMT to a digital signal with 4096 counts of resolution. Since its measurement range is 0 ppb to 2,000 ppb, this only allows about 3 ppb per count. While this might be acceptable for high concentration measurements made in parts per million units (ppm), it is not useful enough for lower level measurements. To overcome this limitation the analyzer is designed with two physical measurement ranges:

- LOW range to measure concentrations from 0 ppb to 50 ppb
- HIGH range to measure the full 2,000 ppb range of the analyzer

The analyzer's CPU chooses the appropriate physical range, by adjusting the hardware gain on the preamp PCA, based on the configuration of the Highest Concentration Range variable in the Setup>Vars menu (see Table 2-8).

4.1.7. INTERFERENTS

The chemiluminescence method for detecting NO_x is subject to interference from a number of sources including water vapor (H₂O), sulfur dioxide (SO₂), and carbon dioxide (CO₂); however, the analyzer has been designed to reject most of these interferents.

4.1.8. DATA RECORDING DEVICES

A strip chart recorder, data acquisition system or digital data acquisition system should be used to record data from either the Ethernet, serial or analog outputs.

- If analog readings are used, the response of the recording system should be checked against a NIST traceable voltage source or meter.
- Data recording devices should be capable of bi-polar operation so that negative readings can be recorded.

For electronic data recording, the analyzers provide an internal data logger, which is configured through the Setup>Data Logger menu (Section 2.5.1).

NumaView™ Remote is a remote control program, which is also available as a convenient and powerful tool for data viewing and handling, download, storage, quick check and plotting.

4.1.9. CONVERSION EFFICIENCY (CE)

The efficiency at which the thermal converters (the molybdenum converter inside the analyzer and the external converter unit, the Model 501) convert either NO₂ or NH₃ to NO directly affects the accuracy of the instrument's gas measurements. The firmware includes a Converter Efficiency (CE) gain factor (view parameters Conv Eff NH₃ and Conf Eff NO₂ in the Dashboard) that is used to calculate the final concentrations for each. These gain factors are stored in the software memory. Over time the converters can become less efficient at converting their respective gases; therefore, in order to ensure accurate performance of the product, it is important to check the CEs periodically.

- The NO₂ CE check procedure is presented in Section 4.5 (should be done prior to NH₃)
- The NH₃ CE check procedure is always part of an NH₃ cal, so both are combined in Section 4.2.1.3.

4.2. CALIBRATION PROCEDURES

Check that the pneumatic connections for the specific instrument configuration are as instructed in Section 2.3.2. Calibration procedures include setting the expected span gas concentration (see Note below).

Verify/change (if needed) the settings in the Setup>Vars menu as follows:

- User Units (unit of Measure): PPB
- Highest Concentration Range (highest concentration expected to measure)
- Range Mode: SNGL

Then perform the calibrations in the following order:

1. Perform a Zero calibration using zero air for NO, NOx, and TNx.
2. Perform an NO span calibration on the NO, NOx & TNx channels using a known concentration of NO span gas.

Note

Tips for Setting the Expected Span Gas Concentration:

- **The expected concentrations for both NO and NOx are usually set to the same value; however, consider impurities in your span gas source (e.g. NO often contains 1-3% NO₂ and vice versa).**
 - **The NO and NOx span gas concentrations should be 80% to 90% of range of concentration values likely to be encountered in your application.**
3. Perform an NO₂ molybdenum (moly)) Converter Efficiency test/check using a known concentration of NO₂ gas. (This is an important step that is required prior to running NH₃ (ammonia) converter efficiency test/check).
 4. Perform an NH₃ (ammonia) Converter Efficiency test/check using a known concentration of NH₃ gas.

To calibrate or to perform a calibration check for basic configuration instruments, see Section 4.2.1.

To calibrate or to perform a calibration check for instruments with valve options, see Section 4.2.2.

To perform a calibration check for instruments with the internal span gas generator, see Section 4.3.

To check NO₂ Conversion Efficiency, see Section 4.5. (NH₃ Conversion Efficiency is part of the NH₃ calibration and check procedures in Section 4.2.1.3).

4.2.1. CALIBRATION AND CHECK PROCEDURES FOR BASIC CONFIGURATION

Although this Section uses the Calibration menu for both check and actual calibration, a check does not require the Calibration menu. Instead, while in Home page, simply flow the zero air or the NO span gas through the Sample port, and check the reading after the Stability falls below 1.0 PPB (either in the gas graph or in the Dashboard).

Otherwise, follow the steps presented in Sections 4.2.1.1 and 4.2.1.2.

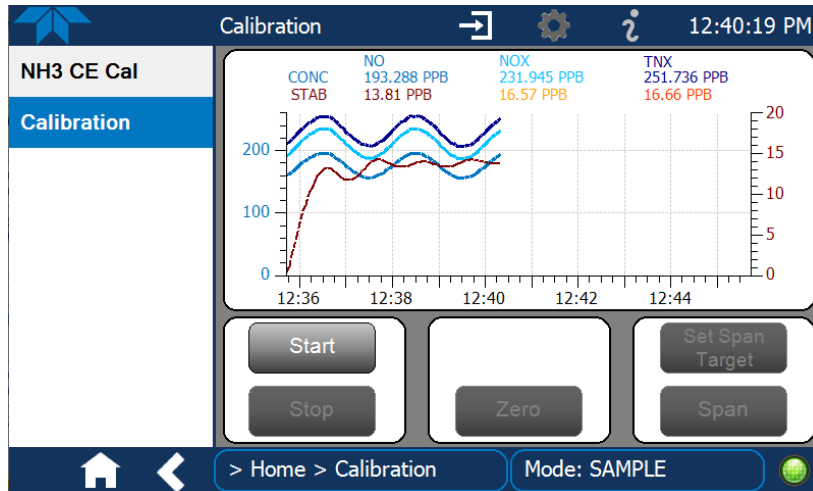

Figure 4-1. Multi-Point Calibration Page

4.2.1.1. ZERO CALIBRATION CHECK AND ACTUAL CALIBRATION

1. Ensure that a leak check has been performed and any repairs if needed before proceeding.
2. In the Calibration>Calibration menu, input Zero air through the Sample port and press the Start button. (If the analyzer had been sampling NH₃ (ammonia) gas prior to this procedure, it may take longer to reach the zero baseline).
3. Either check or calibrate as follows:

CHECK ONLY:

- a. Wait for reading to stabilize.
- b. Press Stop and check the reading.

ACTUAL CALIBRATION:

- a. Press the Zero button.
- b. Press Stop and check the reading.

4.2.1.2. NO SPAN CALIBRATION CHECK AND ACTUAL CALIBRATION

1. Ensure that a leak check has been performed and any repairs if needed before proceeding.
2. While still in the Calibration>Calibration menu, input NO Span gas through the Sample port and press the Start button. (If the analyzer had been

sampling ammonia gas prior to this procedure, it may take longer for the TNx channel to stabilize).

3. Either check or calibrate as follows:

CHECK ONLY:

- a. Wait to reach stability, then press Stop.
- b. Record the reading(s).

ACTUAL CALIBRATION:

- a. Press the Set Span Target button and enter the NO, NOx, and TNx concentrations.
- b. Verify the concentration reading is the same as the NO concentration being supplied.
- c. If correct, wait to reach stability, then press the Span button.
- d. In the Cal Result window, press OK.

4. Press the Stop button and return to Home screen.

5. In the Dashboard, check and record the Slope(s) and the Offset(s). (See Table 4-4 in Section 4.4, Calibration Quality Analysis, for expected/acceptable values).

6. Perform NO₂ Converter Efficiency check/test per Section 4.5.

4.2.1.3. NH₃ (AMMONIA) SPAN CALIBRATION CHECK AND/OR ACTUAL CALIBRATION, AND NH₃ CONVERTER EFFICIENCY (CE) CHECK

Ammonia is a very sticky gas and the response of the analyzer/calibration system depends on a number of factors. The following lists some important points the user should be aware of when calibrating:

- Is this the first time the analyzer/calibration system has seen ammonia gas in the last couple of days? If so, spanning to a fixed value will take considerably longer than normal, possibly 12 hours to completely stabilize.
- Is the tubing that is delivering span gas from the calibration bottles, made of stainless steel? Is the tubing from the rear of the calibrator to the analyzer, made of stainless steel? Where possible use stainless steel tubing.

Note

The operator is responsible for delivering a set amount of ammonia to the analyzer, calculating the converter efficiency of the 501 NH₃ and entering the efficiency value through the user interface, if required.

- Is the environment where the analyzer resides undergoing large temperature swings (+/- 5 °C about the norm temperature)? If so the sample line can absorb and desorb ammonia at concentration rates that are distinguishable to the analyzer. If possible, heat the sample line to a constant maximum ambient temperature.
- Does the sampling environment contain large amounts of particulates? If so, it may be necessary to add the sampling filter option. As outlined previously, this will affect the analyzer response.
- One method to increase the response of both the sampling system and the analyzer is to flow a larger concentration of ammonia gas through the pneumatics for a couple of hours. For example, if the expected range is 500 PPB of ammonia, then flowing 1000 PPB will speed up the absorption which occurs throughout the pneumatics. The

long delays in ammonia response occur when the analyzer hasn't sampled the gas for some time. Ammonia desorbs from the pneumatics; these surfaces need to be rewetted before span stability is achieved.

1. Ensure that a leak check has been performed and any repairs if needed before proceeding.
2. Navigate to the Calibration>NH3 CE Cal menu.

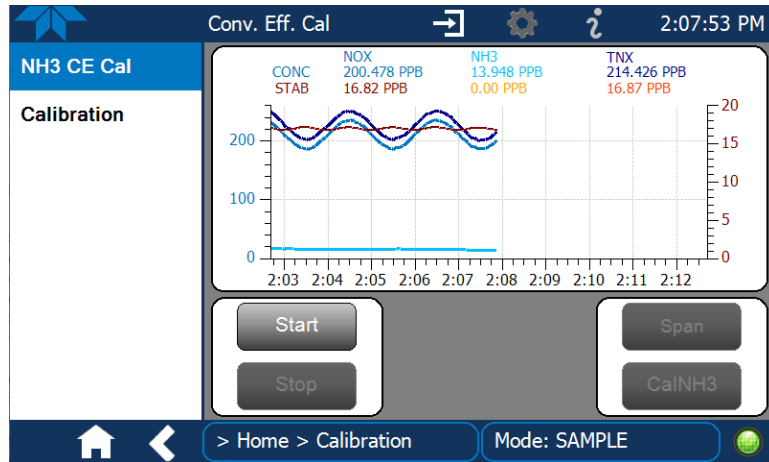

3. Press Span button.
4. Edit the concentration field to match the concentration of the input NH₃ and then press Done to return to the cal screen.
5. Allow the NH₃ to flow until it stabilizes.
6. Press the CalNH3 button to complete the procedure.
7. Navigate to the Dashboard and view the Conv Eff NH3 reading.

4.2.2. CALIBRATION AND CHECK PROCEDURES WITH VALVE OPTIONS INSTALLED

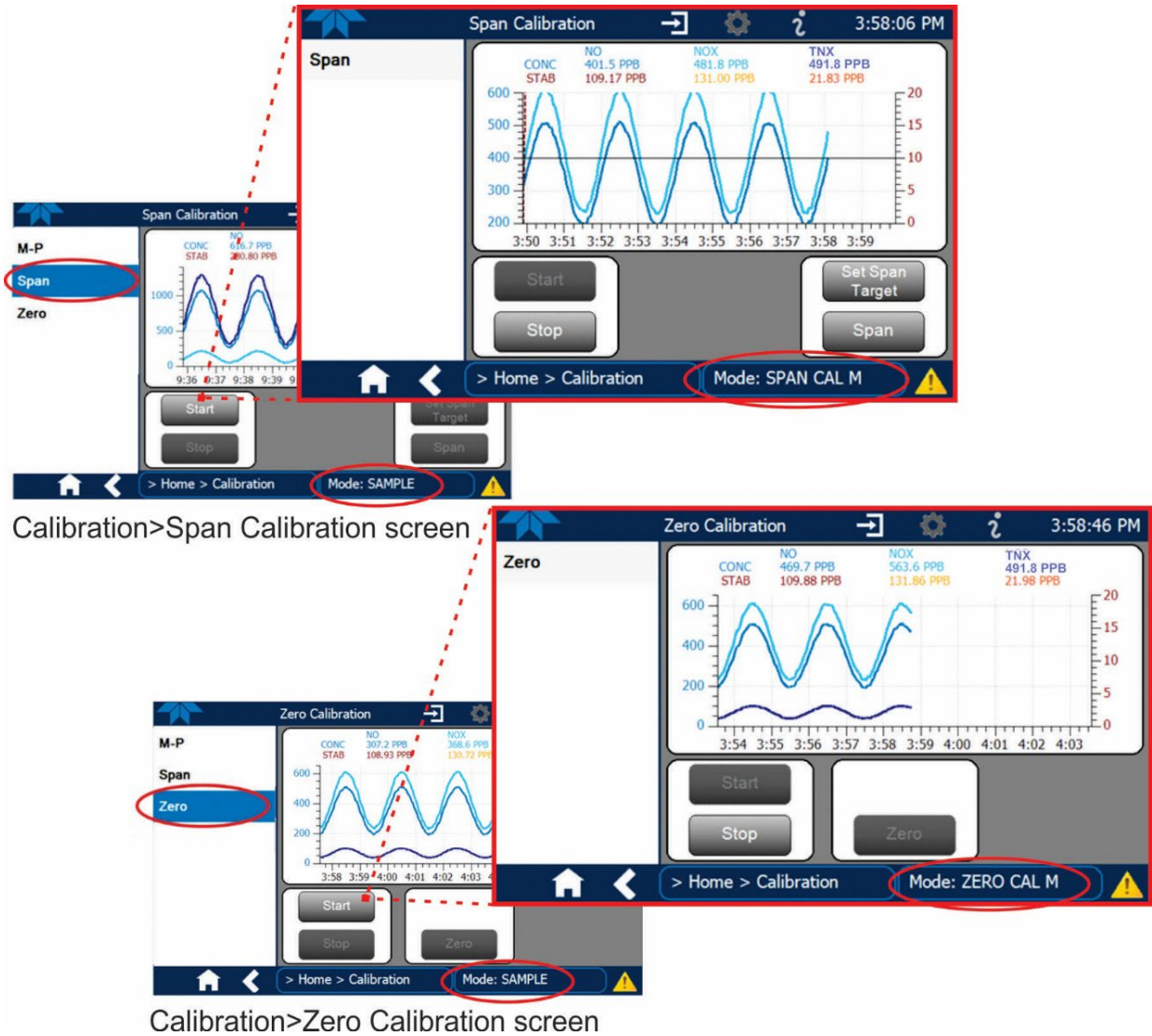

Figure 4-2. Zero and Span Calibration Screens

Follow the instructions in Section 4.2.1, except instead of the M-P menu, go to the Calibration>Zero menu for Zero calibration and to the Calibration>Span menu for NO, NOx, and TNx Span calibrations.

4.2.2.1. USE OF ZERO/SPAN VALVE WITH REMOTE CONTACT CLOSURE

Contact closures for controlling calibration and calibration checks are located on the rear panel CONTROL IN connector. Instructions for setup and use of these contacts are in Section 2.3.1.5.

When the contacts are closed for at least 5 seconds, the instrument switches into zero, low span or high span mode..

- The remote calibration contact closures may be activated in any order.

- It is recommended that contact closures remain closed for at least 10 minutes to establish a reliable reading.
- The instrument will stay in the selected mode for as long as the contacts remain closed.

If contact closures are being used in conjunction with the analyzer’s AutoCal (see Section 4.3) feature and the AutoCal attribute “Calibrate” is enabled (selection box is checked), the analyzer will not recalibrate the analyzer UNTIL the contact is opened. At this point, the new calibration values will be recorded before the instrument returns to SAMPLE mode.

If the AutoCal attribute “Calibrate” is disabled (selection box is unchecked), the instrument will return to SAMPLE mode, leaving the instrument’s internal calibration variables unchanged.

4.3. AUTOMATIC ZERO/SPAN CAL/CHECK (AUTO CAL)

The Auto Cal feature allows unattended periodic operation of the ZERO/SPAN valve options by using the instrument’s internal time of day clock. Auto Cal operates by executing preprogrammed calibrations or calibration checks set up by the user to initiate the various calibration states of the analyzer and to open and close valves appropriately. It is possible to set up and run up to three separate preprogrammed calibrations or calibration checks (labeled # 1, 2 and 3). Each calibration or check can operate in one of three modes (Zero, Low or High), or be disabled.

Table 4-1 and Table 4-2 show how to set up the operating states of each calibration or check, and Table 4-3 shows how to program the execution of each.

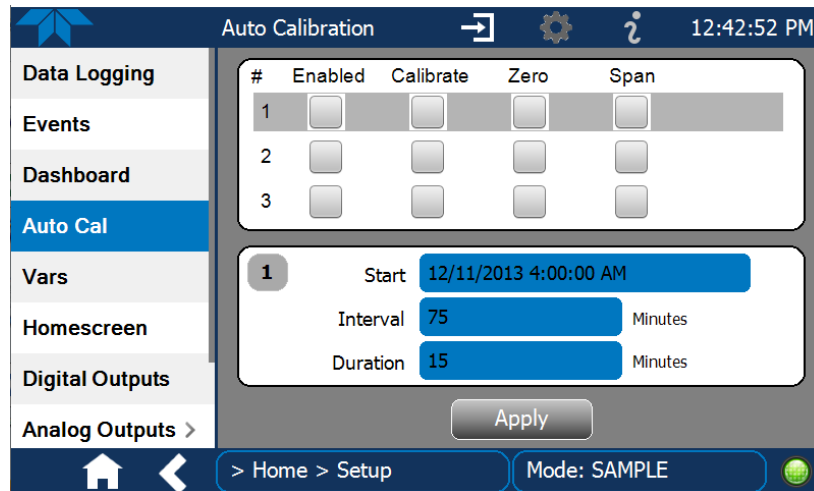

Figure 4-3. Auto Cal Page

Table 4-1. AUTO CAL States

MODE NAME	ACTION
Enabled	<input checked="" type="checkbox"/> enables the sequence; <input type="checkbox"/> disables the sequence.
Calibrate	<input checked="" type="checkbox"/> enables an actual calibration when the Enabled box is also <input checked="" type="checkbox"/> <input type="checkbox"/> allows a calibration check when the Enabled box is also <input checked="" type="checkbox"/> .
Zero	<input checked="" type="checkbox"/> causes the sequence to perform a Zero calibration when both the Calibrate and Enabled boxes are also <input checked="" type="checkbox"/> <input checked="" type="checkbox"/> causes a Zero check when the Enabled box is also <input checked="" type="checkbox"/> and the Calibrate box is unchecked (<input type="checkbox"/>) <input type="checkbox"/> disables Zero calibration and check
Span	<input checked="" type="checkbox"/> causes the sequence to perform a Span calibration when both the Calibrate and Enabled boxes are also <input checked="" type="checkbox"/> <input checked="" type="checkbox"/> causes a Span check when the Enabled box is also <input checked="" type="checkbox"/> and the Calibrate box is unchecked (<input type="checkbox"/>) <input type="checkbox"/> disables Span calibration and check

Table 4-2 shows how the selection boxes would be enabled/disabled for calibration checks and calibrations.

Table 4-2. Auto Cal Setup Combinations

MODE	ACTION	STATE			
		Enabled	Calibrate	Zero	Span
Zero	Check	<input checked="" type="checkbox"/>	<input type="checkbox"/>	<input checked="" type="checkbox"/>	<input type="checkbox"/>
	Calibrate	<input checked="" type="checkbox"/>	<input checked="" type="checkbox"/>	<input checked="" type="checkbox"/>	<input type="checkbox"/>
Span	Check	<input checked="" type="checkbox"/>	<input type="checkbox"/>	<input type="checkbox"/>	<input checked="" type="checkbox"/>
	Calibrate	<input checked="" type="checkbox"/>	<input checked="" type="checkbox"/>	<input type="checkbox"/>	<input checked="" type="checkbox"/>

For each sequence, there are four parameters that control operational details: Date, Time (both in the Start field), Interval, and Duration, as presented in Table 4-3.

Table 4-3. Auto Cal Programming Sequence Execution

ATTRIBUTE	ACTION
Start	When the Enabled box is “on” <input checked="" type="checkbox"/> , the Sequence (identified by its number) begins on the date and time shown in the configurable Start field. (Click the field for the pop-up window and toggle between the Time (Hour/Minutes) and the Date (Year/Month/Day) attributes to edit as needed).
Interval	Number of minutes to skip between each Sequence execution. (Click the field to input the number of minutes in the pop-up window).
Duration	Number of minutes that each Sequence execution is to run. (Click the field to input the number of minutes in the pop-up window).

Important

IMPACT ON READINGS OR DATA

- **The programmed STARTING_TIME must be a minimum of 5 minutes later than the real time clock for setting real time clock (Setup>Instrument, Section 2.5.9).**
- **Avoid setting two or more sequences at the same time of the day.**
- **Any new sequence that is initiated whether from a timer, the COM ports or the contact closure inputs will override any sequence that is in progress.**
- **It is recommended that calibrations be performed using external sources of Zero Air and Span Gas whose accuracy is traceable to EPA standards.**

4.4. CALIBRATION QUALITY ANALYSIS

It is important to evaluate the analyzer’s calibration **SLOPE** and **OFFSET** parameters. These values describe the linear response curve of the analyzer, separately for NO, NO_x, and TN_x. The values for these terms, both individually and relative to each other, indicate the quality of the calibration.

Set up the Data Logger with a Periodic trigger to record the values of the following parameters (see Section 2.5.1).

- NO Offset
- NO Slope
- NO_x Offset
- NO_x Slope
- TN_x Offset
- TN_x Slope

Ensure that these parameters are within the limits listed in Table 4-4 and frequently compare them to those values on the *Final Test and Validation Data Sheet* that came with

your instrument, which should not be significantly different. Otherwise, refer to the troubleshooting Section 5.7.7.

Table 4-4. Calibration Data Quality Evaluation

FUNCTION	MINIMUM VALUE	OPTIMUM VALUE	MAXIMUM VALUE
NO Slope	0.700	1.000	1.300
NOx Slope	0.700	1.000	1.300
TNx Slope	0.700	1.000	1.300
NO Offset	-20.0 mV	0.0 mV	150.0 mV
NOx Offset	-20.0 mV	0.0 mV	150.0 mV
TNx Offset	-20.0 mV	0.0 mV	150.0 mV

4.5. NO₂ CONVERSION EFFICIENCY (CE) CHECK

This Section describes how to determine the molybdenum (moly) converter's efficiency using a GPT method where the actual concentration of ozone is not a factor in the accuracy of the calculation. (Note that the ammonia CE Check is integrated into the Ammonia Calibration section, 4.2.1.3)

- This procedure is based on the Code of Federal Regulations, Title 40, Chapter I, subchapter C, Part 50, Appendix F.
- In the following example a reference point of 450 ppb NO gas will be used. *This is only an example.* Any other reference points within measurement range of the instrument may be used.
- For this procedure use a calibrated O₃ generator, such as a Teledyne API's T700 and the Moly Test Data Sheet provided in Section 4.5.2 following these instructions.

Note

The nitrogen dioxide converter efficiency factor must be calculated by running a conversion efficiency (CE) check using gas phase titration (GPT) as set forth here in Section 4.5. This value gives a good indication of how well the molybdenum is converting nitrogen dioxide into nitric oxide. In a properly functioning analyzer, the CE value should be close to 1.0. It is recommended that the molybdenum efficiency be checked every three months. The formulae used for calculating ammonia and nitrogen dioxide concentrations can be found in Section 6.

Note

There must be a minimum of 10% more NO than O₃ produced. Example, if the O₃ concentration used is 400 ppb, then the NO concentration used must be 440 ppb or more. Typically, 450 PPB NO is titrated against 400 PPB of Ozone.

4.5.1. NO₂ CE CHECK PROCEDURES

1. Leak check machine to ensure that there are no leaks in the analyzer.
2. Calibrate the instrument at the same NO span gas value as being used in this method.
 - For this example we use 450 ppb NO span gas
3. Bypass the moly converter by placing a short piece of tubing in the gas stream in place of the converter.
4. Perform a straight dilution with 450 ppb NO gas & air as a diluent gas.
5. Input the NO gas into the analyzer.
6. Allow the machine to stabilize & write down the NO_x value on line 2 of Moly Test data sheet (Section 4.5.2).
7. Remove the converter bypass so that the NO gas is flowing through the converter again.
8. Allow the machine to stabilize.
9. Write down your NO_x value on your data sheet on lines 3 AND line 5 of the data sheet.
10. Subtract line 2 from line 3 & write that number down on line 4. Also write the NO value on line 8 of the data sheet.
 - The specification shown on the data sheet is the value that is used by Teledyne API when performing the procedure on new NO₂ → NO converters.
 - Older NO₂ → NO converters might outgas a bit more NO, therefore a slightly wider specification might be in order.
 - If this value is a constant or changes only slightly over time, this is not a problem the machine will calibrate this out.
11. Generate the same 450 ppb NO gas and input 400 ppb of O₃ (or generate 450 ppb NO & 400 ppb NO₂, if that's what your calibrator says).
12. Allow the instrument to stabilize for 10 minutes.
13. Write down the NO_x value on line 6 & the NO value on line 9.
14. Subtract line 6 from line 5 & put that onto line 7.
15. Subtract line 8 from line 7 & put that onto line 10.
16. Write the number from line 7 into the blank next to letter A on line 11 & put the number from line 10 into the blank next to letter B on line 11.
17. Divide A by B & multiply it by 100.
18. Write this value it into the blank next to letter C on lines 11 and 12.
19. Subtract that value from 100 & write it in the blank next to the letter D on line 12.
20. This is the converter efficiency.
 - This value should be >96%.



4.5.2. NO₂ Moly CE Check Data Sheet

Line #	CHECK	RESULT
1	LEAK-CHECK (WHEN HOT)	YES / NO
2	NO _x RESPONSE (MOLY BYPASSED)	_____
3	NO _x RESPONSE (MOLY IN-LINE)	_____
4	OUT-GASSING (NO – NO _x)	_____ (>-5 ppb, <5 ppb)
5	(NO _x ORIG) (NO _x mode, O ₃ off)	_____ ppb
6	(NO _x REM) (NO _x mode, O ₃ on)	_____ ppb
7	NO _x LOSS	_____ (A) (<4% of NO _x ORIG; example: for 450PP 4% is 18 ppb)
8	(NO ORIG) (NO mode, O ₃ off)	_____ ppb
9	(NO REM) (NO mode, O ₃ on)	_____ ppb
10	NO ₂ _____ (B) (>300ppb)	
11	Efficiency LOSS [(A / B) x 100] = [(_____ A / _____ B) x 100] = _____ C %	
12	Total Conv Eff [100% – C] = 100% - _____ C = _____ D % (> 96%)	

5. MAINTENANCE AND SERVICE

Follow the maintenance schedule set forth in Section 5.1. Service and troubleshooting are covered in Section 5.7.

ATTENTION

COULD DAMAGE INSTRUMENT AND VOID WARRANTY
Avoid spraying anything directly onto any part of the analyzer.

5.1. MAINTENANCE SCHEDULE

Table 5-1 shows a typical maintenance schedule.

In certain environments (e.g., dusty, very high ambient pollutant levels) some maintenance procedures may need to be performed more often than shown.



WARNING – ELECTRICAL SHOCK HAZARD

Disconnect power before performing any of the following operations that require entry into the interior of the analyzer.



CAUTION – QUALIFIED PERSONNEL

These maintenance procedures must be performed by qualified technicians only.

Important

IMPACT ON READINGS OR DATA

A span and zero calibration check (see CAL CHECK REQ'D Column of Table 5-1) must be performed following some of the maintenance procedures listed herein. To perform a CHECK of the instrument's Zero or Span Calibration, refer to Sections 4.2.1.1 and 4.2.1.2, respectively.

DO NOT press the Zero or Span buttons at the end of each operation (actual calibration), as this will reset the stored values for OFFSET and SLOPE and alter the instrument's calibration.

Alternatively, use the Auto Cal feature described in Section 4.3 with the CALIBRATE attribute set to OFF (not enabled).

Table 5-1. Maintenance Schedule

ITEM	ACTION	FREQ	CAL CHECK REQ'D	DATE PERFORMED													
Dashboard functions	Review and evaluate	Weekly	No														
Particulate filter	Change	Monthly or as necessary	No														
AutoZero flow	Check as needed	Every 3 months	No														
501 Converter	Test	Every 3 months	Test - No Replace - Yes														
	Replace as necessary	Annually															
Zero/span check	Evaluate offset and slope	Weekly	No														
Zero/span calibration	Zero and span calibration	Every 3 months	Yes														
External zero air scrubber option	Exchange chemical	Every 3 months	No														
External dryer option	Replace chemical	When indicator color changes	No														
Software/ Firmware	Check for updates	Every 6 months or whenever serviced	Yes														
Ozone cleanser	Change chemical	Annually	Yes														
Reaction cell window ("optical filter")	Clean	Annually or as necessary	Yes														
DFU filters	Change	Annually (or as needed for highly polluted sample air)	No														
Pneumatic sub-system	Check for leaks in gas flow paths	Annually or after repairs involving pneumatics	Yes if a leak is repaired														
Reaction cell O-rings & sintered filters	Replace	Annually	Yes														
PMT Sensor Hardware Calibration	Low-level hardware calibration	When PMT/ preamp changes or if slope is outside of 1.0±0.3	Yes														
Pump	Rebuild head	when Rx Cell pressure exceeds 10 in-Hg-A (at sea level)	Yes														
Inline Exhaust Scrubber	Replace	Annually	No														
NO ₂ converter	Replace converter	Every 3 years or if conversion efficiency drops below 96%	Yes														
Desiccant bags	Replace	Any time PMT housing is opened for maintenance	n/a														

5.2. PREDICTIVE DIAGNOSTICS

Predictive diagnostic functions, including failure warnings and alarms built into the analyzer's firmware, aid in determining whether and when repairs are necessary.

Dashboard Functions can also be used to predict failures by looking at how their values change over time, compared to the values recorded on the printed record of the *Final Test and Validation Data Sheet*. The internal data logger is a convenient way to record and track these changes (set up through the Data Logger, Section 2.5.1). Use NumaView™ Remote to download and review this data from a remote location.

The following table, checked weekly, can be used as a basis for taking action as these values change with time.

Table 5-2. Predictive Uses for Dashboard Functions

FUNCTION	EXPECTED	ACTUAL	INTERPRETATION & ACTION
Rx Cell Press (pressure)	Constant to within ± 0.5 in-Hg-A	Fluctuating	Developing leak in pneumatic system. Check for leaks.
		Slowly increasing	Pump performance is degrading. Rebuild pump when pressure is above 10 in-Hg-A.
Sample Press (pressure)	Constant within atmospheric changes	Fluctuating	Developing leak in pneumatic system. Check for leaks.
		Slowly increasing	Flow path is clogging up. Replace orifice filters.
		Slowly decreasing	Developing leak in pneumatic system to vacuum (developing valve failure). Check for leaks.
O3 Flow	Constant to within ± 15	Slowly decreasing	Flow path is clogging up. Replace orifice filters.
Auto Zero	Constant within ± 20 of check-out value	Significantly increasing	Developing AUTO ZERO valve failure. Replace valve.
			PMT cooler failure. Check cooler, circuit, and power supplies.
			Developing light leak.
			O ₃ air filter cartridge is exhausted. Change chemical.
NO2 Conc	Constant for constant concentrations	Slowly decreasing signal for same concentration	Converter efficiency may be degrading. Clean or replace converter components.
NO Conc	Constant for constant concentration	Decreasing over time	Drift of instrument response; clean RCEL window. Check for flow leaks or irregularities.
NH3 Conc	Constant for constant concentration	Decreasing over time	Converter efficiency may be degrading. Clean or replace converter components.
TNX Conc	Constant for constant concentration	Decreasing over time	Converter efficiency may be degrading. Clean or replace converter components.

5.3. OPERATIONAL HEALTH CHECKS

Navigate to the Utilities>USB Utilities>Report menu (Figure 5-1) to download a report on the basic operations of the instrument. To download the report for your own viewing on a computer or to send to others, insert a flash drive into a front panel USB port and press the Download button, which is enabled when the instrument detects the flash drive.

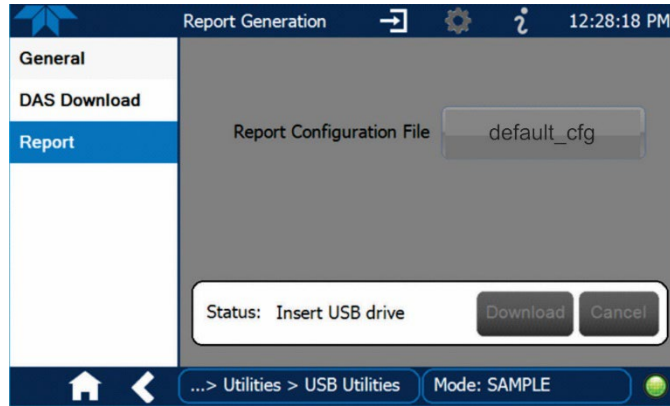

Figure 5-1: Report Generation Page

The report can also be set to generate periodically and sent to a Web services “cloud” where it is available for viewing by Teledyne API technical support personnel. Set this function with two Vars:

Setup>Vars>Upload Report to Cloud: set to True.

Setup>Vars>Report Upload>Interval: edit the number of hours between report uploads.

5.4. SOFTWARE/FIRMWARE UPDATES

There are two ways to check for and acquire updates: either remotely or manually.

5.4.1. REMOTE UPDATES

The instrument must be connected to a network that is connected to the Internet. In the Setup>Instrument menu, select the Remote Update menu and press the Check for Updates button. If an update is available, it can be downloaded through this page.

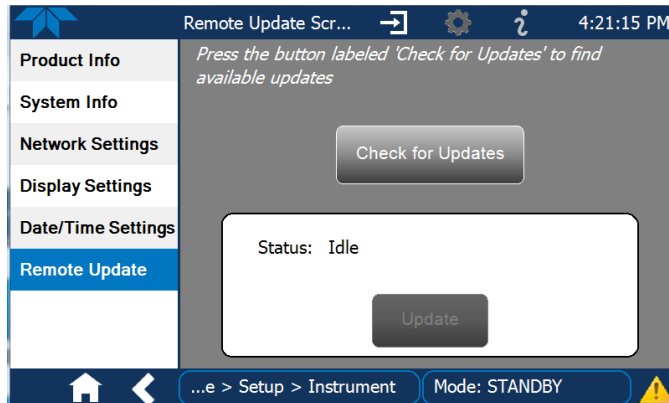

Figure 5-2. Remote Update Page

5.4.2. MANUAL RELOAD/UPDATE PROCEDURES

To reload or update firmware, first contact Technical Support to obtain the applicable file(s): api-techsupport@teledyne.com /+1 800-324-5190.

1. Follow Technical Support's instructions for copying the firmware files to a flash drive.
2. Go to the Utilities>USB Utilities>General menu.

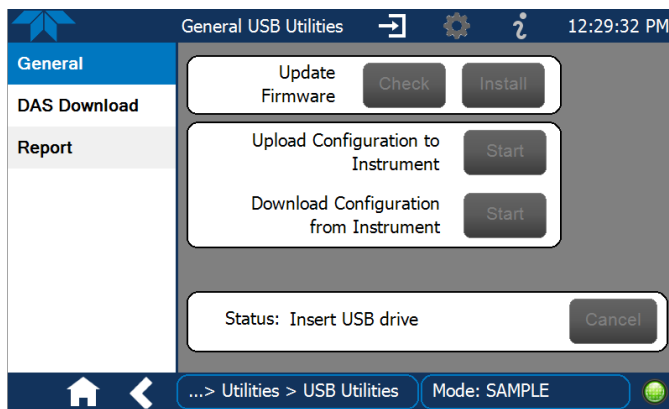

Figure 5-3. Manual Update Page (and other utilities)

3. Insert a flash drive into a front panel USB port and wait for the Status field to indicate that the drive has been detected.
4. In the Update Firmware field, press the Check button for the instrument to determine whether the firmware on the flash drive is more recent than what is

currently installed. Once it's been determined that the firmware is new, the Install button will be enabled; if the firmware version on the flash drive is the same as or older than the current firmware of the instrument, the Install button will not be enabled.

5. Press the Install button, and note the messages in the Status field at the bottom of the page. Use the Cancel button if necessary.
6. When complete, as indicated in the Status field, press the Done button, which replaces the Cancel button, and remove the flash drive.
7. Power off and restart the instrument to complete the new firmware installation.

5.5. TIME ZONE CHANGES

There is an option to change between 12-hour and 24-hour format in the Setup>Vars menu (System Time Format). Effectively changing the Time Zone requires a specific procedure as follows:

1. In Setup>Instrument>Date/Time Settings select the applicable Time Zone.
2. Allow adequate time for the selected Time Zone to be properly accepted.
3. Verify: return to Home page then back to the Date/Time Settings page, and check that the selected Time Zone is now highlighted.
4. Without making any other changes, power OFF the instrument and power ON again.
5. Once restarted, return to the Date/Time Settings page where the newly selected Time Zone should be highlighted. (If not, it means that not enough time had passed for the instrument to accept the change before the power was cycled OFF).
6. After the Time Zone is implemented first (Steps 1 through 5), then other changes to the date and/or time can be made, and recycling the power is not necessary.

- ① Time zone change must be set **first**.
- ② **Wait**. Allow sufficient time to accept new Time Zone.
- ③ **Verify**. Return to Home page, then return to Date/Time Settings page.
- ④ After correct Time Zone is displayed, **power recycle** the instrument.
- ⑤ Only after Time Zone is selected and instrument rebooted, can other changes to date and/or time be made effectively.

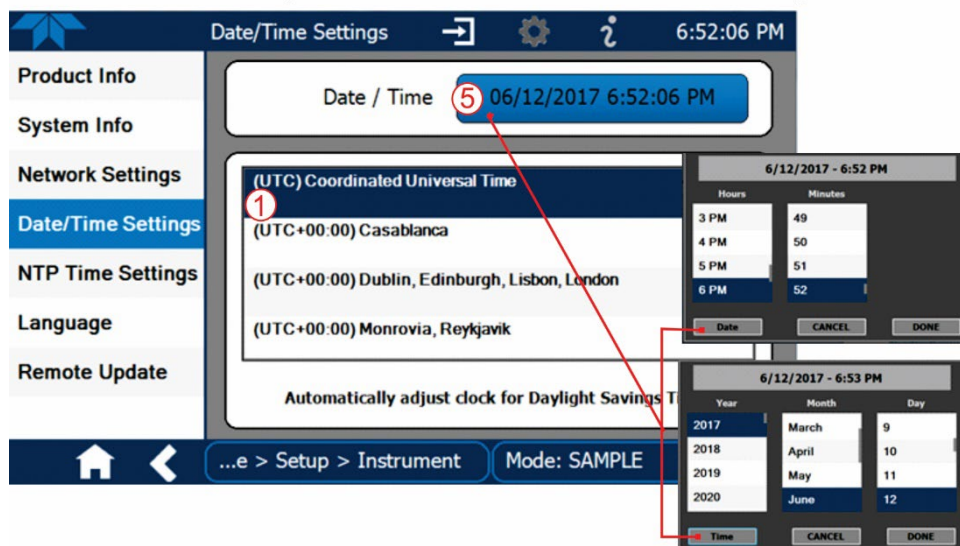

Changes to date and/or time do **not** require a reboot.

Figure 5-4. Time Zone Change Requirements

5.6. HARDWARE MAINTENANCE PROCEDURES

Perform the following procedures as standard maintenance per Table 5-1.

5.6.1. CHECKING THE AUTOZERO FLOW

Since the T201 is an ammonia analyzer, the flow through the AutoZero orifice is especially important. Check the AutoZero flow as follows:

1. This procedure should be performed with the sample pump running.
2. Remove the top cover of the analyzer. Locate the vacuum manifold at the center rear of the chassis. Locate the 1/8" tube fitting located on the very left side, as viewed from the rear of the analyzer. It will have a label of "0.010" indicating the flow orifice installed.
3. Remove the fitting and attach a calibrated flowmeter to the block fitting capable of measuring in the range of 500 cc/min. The flowmeter should indicate a flow of 500 cc/min \pm 10%.
4. If the flow is outside this range (most likely lower, due to plugging):
 - a. Turn off the sample pump and instrument.
 - b. Remove the 1/8" pipe-to-tube fitting and remove the 1/4" sintered filter (p/n FL0000001). This filter is meant to protect the orifice; it will usually become plugged and need replacement rather than the orifice. Replace the filter, and then re-assemble the manifold. Restart the sample pump and recheck the flow.

Table 5-3. Flow Check

501 NH₃ CONVERTER SAMPLE FLOW CHECK		
Note: Connect both the Teflon™ tubes between analyzer and converter.		
Gas Port	Expected Flow (cc/min)	
"SAMPLE IN"	1000 +/- 10 %	
ANALYZER SAMPLE FLOW CHECK		
Note: Disconnect both the Teflon™ tubes between analyzer and converter.		
Gas Port	Expected Flow (cc/min)	
"TO CONV"	1000 or 500, +/- 10 %	When the analyzer is sampling TNx only, the bypass flow is measured. Therefore, the flow alternates between 500 and 1000 cc/min. This is the NOx channel.
"FROM CONV"	500 +/- 10%	This is the TNx channel.

5.6.2. MAINTAINING THE 501 CONVERTER

The 501 NH₃ external converter is operated at 825 °Celsius. Because of this the stainless steel ¼” tube internal to the converter slowly oxidizes and may require replacement. Over time the converter’s efficiency will degrade, due to aging of the internal catalyst. This is characterized by a CONV value on the TNx channel of < 0.8 or > 1.2, despite the converter being at temperature. The efficiency of the converter should be checked quarterly. The converter should be cleaned out on a yearly basis by removing the outer tube and shaking the fine dust particles from both the outer and inner tubes. This is also a good time to replace the catalyst screen, if necessary.

The following procedure describes how to disassemble and replace converter parts. The various parts in the converter become delicate and brittle after prolonged exposure to high temperatures. It is therefore a good idea to have a complete set of replacement parts on hand:

- Retrofit Kit, 501 NH₃ inner tube with screen
- Rebuild Kit, ceramic bushings, 501 NH₃
- Ceramic Heater, 220W@60V, 501xx

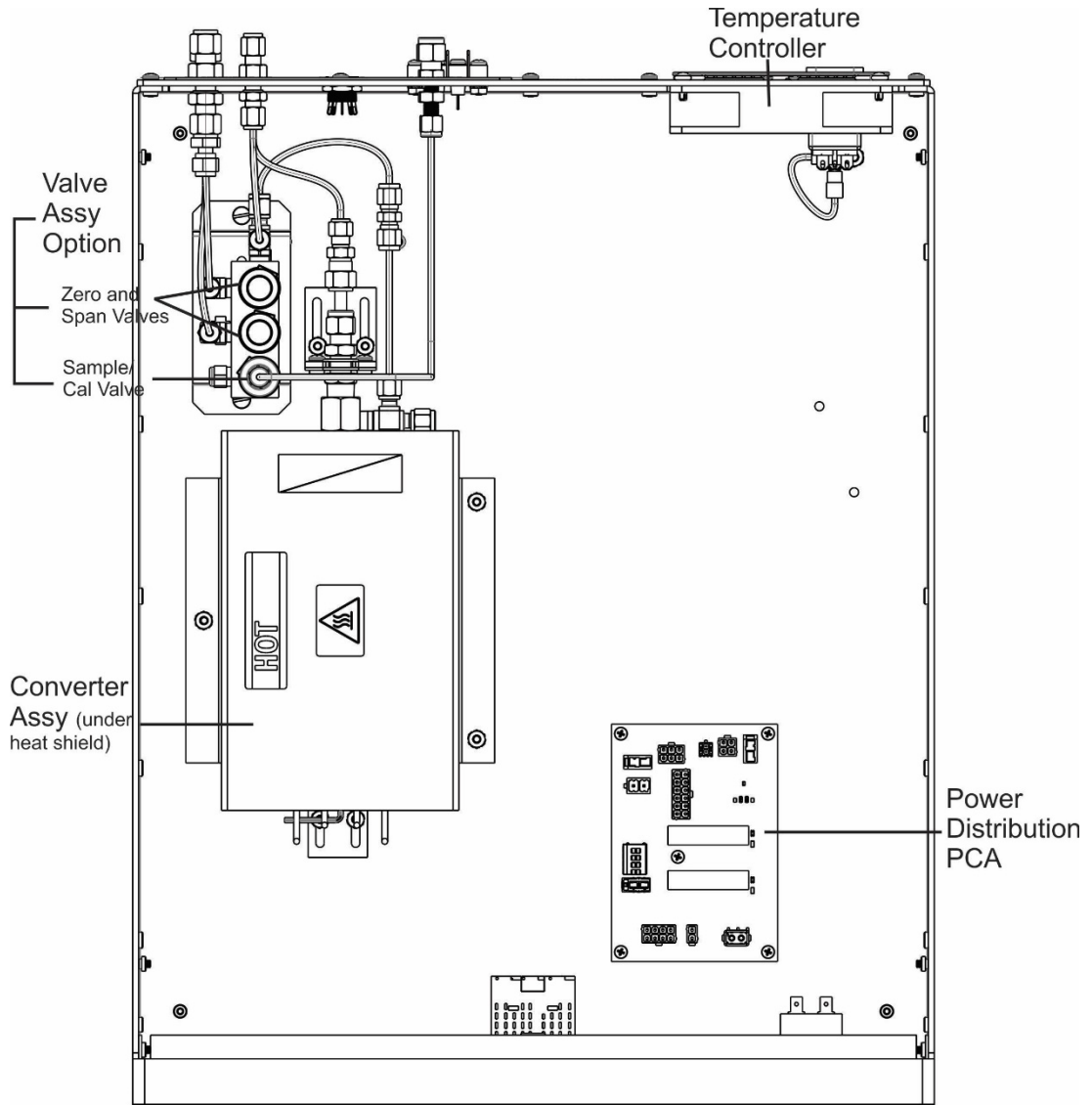

Figure 5-5. Model 501 Chassis Internal Layout

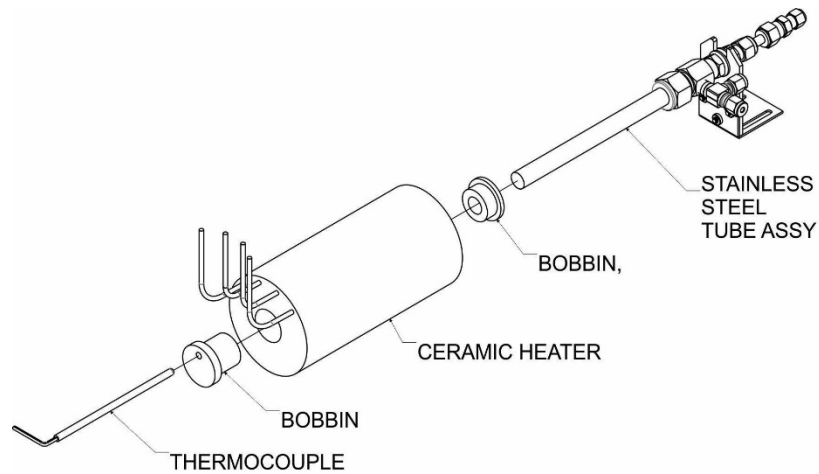

Figure 5-6. Model 501 Converter, Exploded View

5.6.2.1. REPLACING THE CATALYTIC CARTRIDGE



CAUTION – PERSONAL INJURY HAZARD

Will cause severe burns. Ensure that the Converter is cool before attempting any disassembly or repairs.

ATTENTION

COULD DAMAGE INSTRUMENT AND VOID WARRANTY
Disassembly while hot will damage other Converter components. Allow sufficient time to cool.

1. Turn off power to the Converter and allow to cool.
2. Remove the chassis cover of the 501 NH₃, remove the aluminum cover over the oven, and remove the two U-shaped hold-down clamps.
3. Disconnect the 1) stainless steel and 2) PTFE tubes from the converter cartridge.
4. Loosen the nut holding the cartridge assembly in the U-shaped angle bracket mounted on the chassis floor.
5. Gently lift and tilt the converter assembly out of the U-shaped bracket and slide the assembly out of the oven.
6. Loosen the 1/4" SS tube fitting nearest the hold-down bracket; this fitting holds the central tube in the converter. Replace the tube that is part of the Rebuild Kit.
7. Re-assemble the converter by doing the above steps in reverse order.

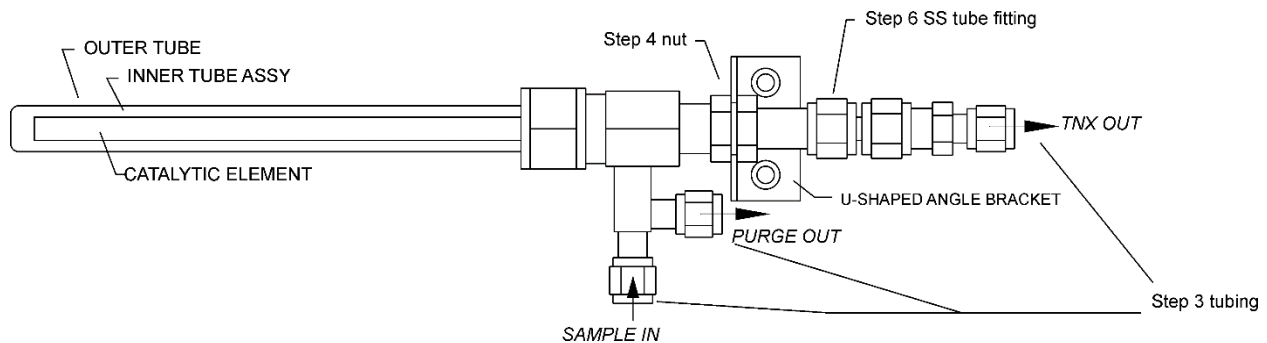

Figure 5-7. Catalytic Cartridge

5.6.2.2. REPLACING THE THERMOCOUPLE

ATTENTION

COULD DAMAGE INSTRUMENT AND VOID WARRANTY

Use only Type S thermocouple in the 501 NH₃ Converter. It can be distinguished by its wire colors: red and black. If you have any other thermocouple, do NOT install it; call TAPI to obtain the correct part.

Have the following ready:

- Replacement parts kit for Type S thermocouple
- Nutdriver, $\frac{5}{16}$
- Nutdriver, $\frac{11}{32}$
- Diagonal Cutter
- Philips head Screwdriver #2

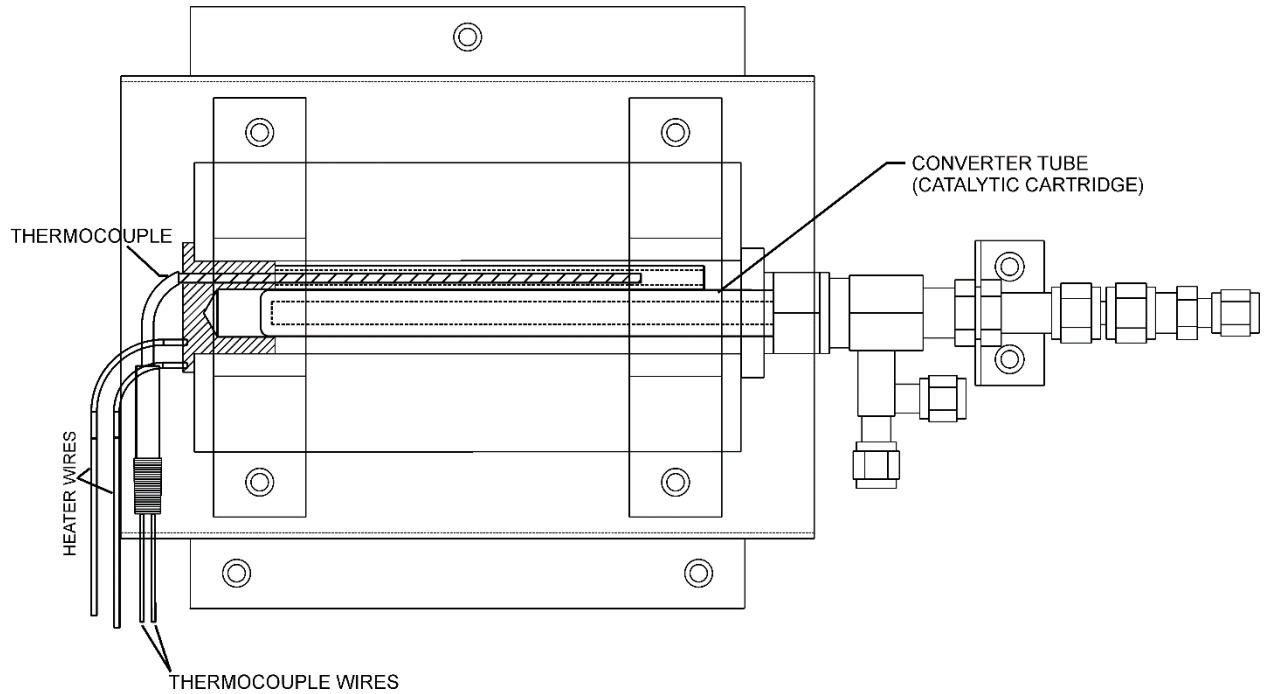

Figure 5-8. Thermocouple Location

Once you have the right tools and parts, referring to Figure 5-9 replace the thermocouple as follows:

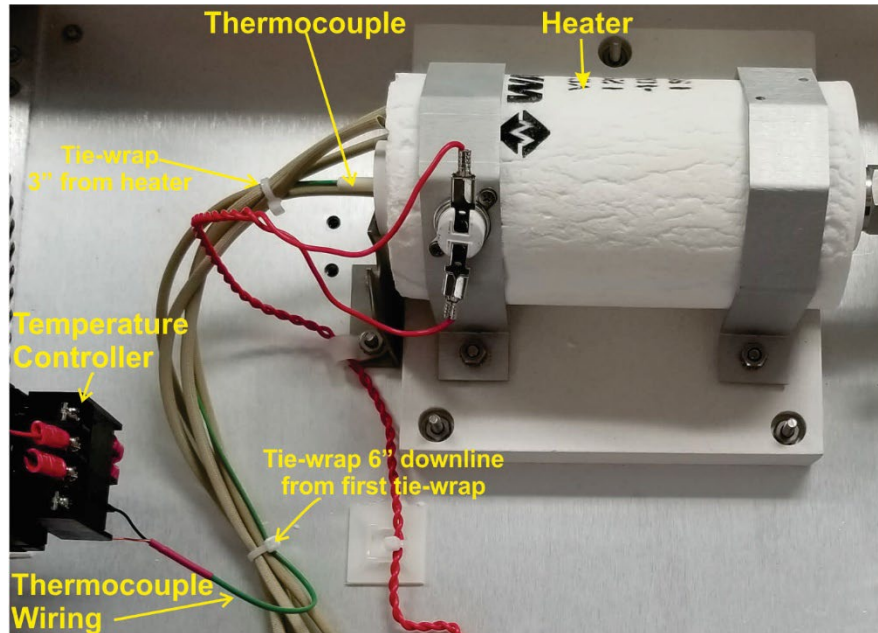

Figure 5-9. Thermocouple and Wiring Location

1. Ensure power is removed from the 501 NH₃ Converter. If the Converter has been operational you will need to wait for at least 2 hours for the Converter oven to cool before continuing with the replacement of the thermocouple.
2. Remove the cover from the Converter chassis.
3. Unscrew the (4) nuts that secure the front panel to the chassis. They are located just behind the front panel along the top.
4. Cut the tie-wraps that hold the lead wires and the thermocouple wires.
5. Loosen the terminals on the Temp Controller to release the thermocouple wire, noting which wire is connected to which pin.
6. Slide the thermocouple from the bobbin at the end of the heater.
7. Slide the replacement thermocouple into the bobbin of the heater, ensuring that $\frac{3}{4}$ " to 1" of thermocouple body (white portion) remains outside the bobbin.

ATTENTION

RISK OF DAMAGE TO COMPONENT

The thermocouple wire can melt if too close to the heater; ensure that the thermocouple is no closer to the heater than the recommended distance.

8. Connect the (2) wires of the new thermocouple to the corresponding terminals of the Temperature Controller (black wire to pin 1, red wire to pin 2).
9. Secure the lead wires and the thermocouple wires with tie-wraps, ensuring that the first tie-wrap is 3" from heater, and that the second tie-wrap is 6" from the first (this is important for stability to ensure that the thermocouple remains securely in place).

10. At this point, all connections have been made, both electrically and pneumatically. A leak check should be performed on the Converter to verify that all connections are leak free. If a leak is detected, the leak should be resolved before continuing.
11. Close the front panel and secure with the (4) nuts. Install the top cover on the Converter chassis.
12. The Converter is now ready for the application of power. You will be looking for an indication from the Temperature Controller that it is functioning correctly and driving the heater to the desired “set” temperature. Apply power now.
13. After the Converter comes to the regulated temperature, perform the Auto Tune function to tune the Temperature Controller to the new thermocouple. (Consult with Technical Support for this procedure).
14. After the Auto-Tune process is completed, verify that the “process” temperature is indicating that the desired temperature is stable and being regulated.

The converter is now ready for operation.

5.6.3. CHANGING THE O₃ DRYER PARTICULATE FILTER

The air for the O₃ generator passes through a dryer equipped with a small particulate filter at its inlet, which prevents dust from entering the ozone dryer and degrading the dryer’s performance over time. Change the filter as follows:

1. Before starting the procedure, check and record the average Rx Cell Press and the O₃ Flow values in the Dashboard. (If not visible, see Section 2.5.3 to configure).
2. Turn off the analyzer, unplug the power cord and remove the cover.
3. Unscrew the nut around the port of the filter using two 5/8” wrenches.

ATTENTION

COULD DAMAGE INSTRUMENT AND VOID WARRANTY

Ensure to use proper wrenches.

Hold the main dryer fitting with a 5/8” wrench to ensure that it does not turn against the dryer.

Performing this procedure improperly or with incorrect tools creates the risk of causing a significant leak.

4. Take off the old filter element and replace it with a suitable equivalent (Teledyne API P/N FL-3).

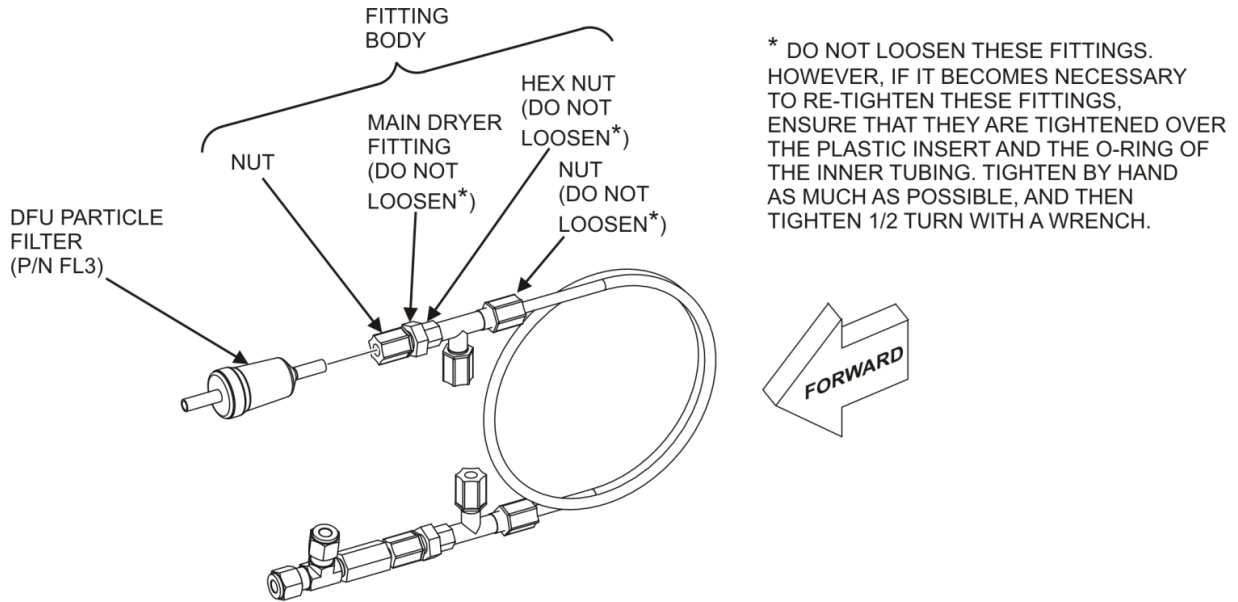

P/N 04543A

Figure 5-10. Particle Filter on O₃ Supply Air Dryer

5. Hold the main dryer fitting steady with a 5/8" wrench and tighten the nut with your hands.
6. If necessary use a second wrench but do not over-tighten the nut.
7. Replace the cover, plug in the power cord and restart the analyzer.
8. Check the O₃ flow (O₃ Flow) rate; it should be around 80 cc/min ± 15.
9. Check the Rx Cell Press; it should be the same value as before.
10. Refer to Section 5.6.10 to perform a leak check after installing the new DFU particle filter.

5.6.4. CHANGING THE OZONE CLEANSER CHEMICAL

The ozone (O₃) cleanser (Figure 5-11) is located next to the O₃ generator (see Figure 2-4 for location) and cleans the O₃ stream from solid and liquid contaminants that are created inside the O₃ generator. The content of the ozone cleanser needs periodical exchange according to Table 5-1. A rebuild kit is available from the factory (contact Technical Support (Section 5.9).

To change the ozone cleanser chemical, follow these steps:

1. Turn off power to the analyzer and pump.
2. Remove the analyzer cover and locate the O₃ filter in the front of the analyzer next to the O₃ generator.
3. Use a 7/16" wrench to remove both pieces of 1/8" male nut with tubing from the NPT fittings.

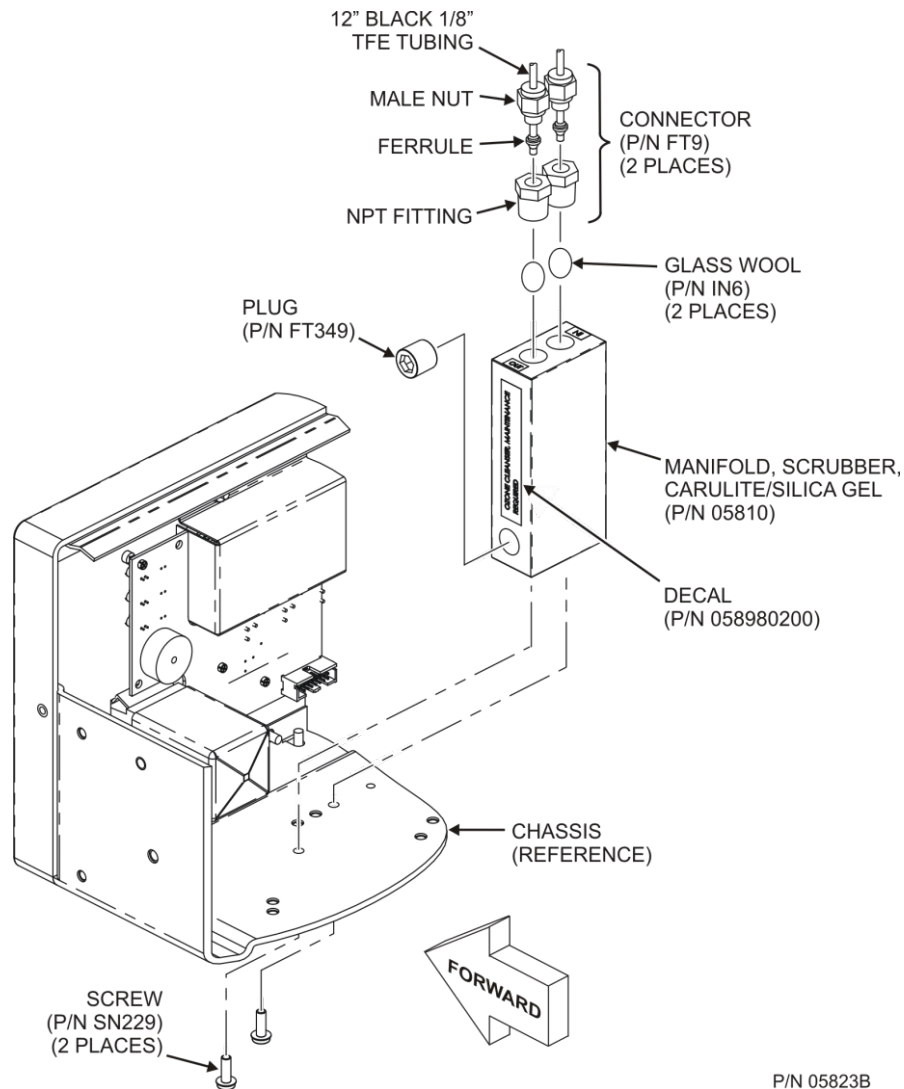

P/N 05823B

Figure 5-11. Ozone Cleanser Assembly

4. Remove the integrated screws with a Phillips screw driver and remove the scrubber manifold from the chassis.
5. Using a 9/16" wrench, remove both fittings from the cartridge.
6. Discard the glass wool.
7. Pour the contents of the scrubber manifold onto a sheet of white paper. If necessary, remove the plug to ensure that all the contents are poured out.
 - Notice any discoloration of the contents, which is usually white and slightly transparent.
 - The amount of discolored chemical (usually with yellow tint) may give you an indication of the lifetime of the chemical in your application.
 - The maintenance cycle of this item is dependent on ambient moisture, sub-micron particle load and other factors and may differ from that shown in Table 5-1.

8. Discard the used silica gel desiccant without touching it. It may contain nitric acid, which is a corrosive and highly irritating substance.



CAUTION – GENERAL SAFETY HAZARD

Immediately wash your hands after contact with the silica gel desiccant.

9. Using a small powder funnel, fill the cartridge with about 10g new silica gel desiccant (Teledyne API P/N CH43) so that it is level on both legs of the cartridge.
 - Slight vibration is required to settle the chemical into the cartridge and achieve tightest packing, which increases performance and lifetime of the filter.
 - Ensure that the level of the chemical does not protrude farther than the first two threads of the NPT fitting.

Important

IMPACT ON READINGS OR DATA

Use only genuine, pre-conditioned Teledyne API's refill kits for this procedure. Teledyne API's refill kits have been properly conditioned to prevent a significant increase of the Auto Zero value which can cause large negative offsets, which may take 2-3 weeks to disappear.

Do not leave this material uncovered for more than a few seconds, as it will absorb contaminants from ambient air. Always store unused, well-covered refill material in a cool dry place.

10. Seal the silica gel desiccant with 1 cm³ of glass wool on each well.
 - Ensure that the plug is large enough and compressed into the cartridge so that the chemical is securely held in place.
11. Add new Teflon tape to the NPT fittings.
12. Screw the NPT fittings back into the scrubber manifold.
13. Screw the cartridge back onto the chassis; orientation is not important.
14. Evaluate the ferrules on the tubing.
 - If the ferrules are too old, we recommend replacing them with new ferrules.
15. Reconnect the tubing using 7/16" and 9/16" wrenches.
 - Do not over-tighten the fittings.
16. If the service interval for this item has been exceeded, it may also be necessary to clean the reaction cell as described in Section 5.6.7.
17. Leak check the system using the pressurized approach described in Section 5.6.10.2.
 - If necessary, tighten the fittings some more but do not over-tighten.
18. Restart the analyzer and pump and continue operation.
19. Recalibrate the analyzer after one hour (Section 4).
 - If Auto Zero is high or is changing/not constant, you may have to wait a day until the silica gel is conditioned before recalibrating the instrument.

5.6.5. MAINTAINING THE EXTERNAL SAMPLE PUMP (PUMP PACK)

5.6.5.1. REBUILDING THE PUMP

The sample pump head periodically wears out and must be replaced when the reaction cell pressure (Rx Cell Press) exceeds 10 in-Hg-A (at sea level; adjust this value accordingly for elevated locations).

- A pump rebuild kit is available from the factory. Refer to the label on the pump for the part number. Instructions and diagrams are included in the kit.
- A flow and leak check after rebuilding the sample pump is recommended.
- A span check and re-calibration after this procedure is necessary as the response of the analyzer changes with the Rx Cell Press.

5.6.5.2. REPLACING THE SCRUBBER



CAUTION!

Do NOT attempt to change the contents of the inline exhaust scrubber cartridge; change the entire cartridge.

1. Through the Utilities>Diagnostics menu turn OFF the O₃ Gen Override. Wait 10 minutes to allow pump to pull room air through scrubber before proceeding to the next step.
2. Disconnect exhaust line from analyzer.
3. Turn off (unplug) analyzer sample pump.
4. Disconnect tubing from (NO_x or charcoal) scrubber cartridge.
5. Remove scrubber from system.
6. Dispose of according to local laws.
7. Install new scrubber into system.
8. Reconnect tubing to scrubber and analyzer.
9. Turn on pump.
10. Through the Utilities>Diagnostics menu (per Step 1 above) turn ON the O₃ Gen Override.

5.6.6. CHANGING OR CLEANING THE NO₂ CONVERTER

The NO₂ converter is located in the center of the instrument, see Figure 2-4 for the location and Figure 5-12 for the assembly.

The converter is designed for replacement of the cartridge only; the heater with built-in thermocouple is to be reused.



CAUTION! PERSONAL SAFETY HAZARD

Wear gloves prior to changing the NO₂ Converter to ensure that the fiberglass insulation does not come into contact with your skin.

1. Power OFF the instrument.
2. Remove the instrument cover and allow the converter to cool.
3. Remove the converter assembly cover as well as the Moly insulation (top layer and corner cut out layers) until the Moly converter assembly can be seen.



CAUTION! HOT SURFACE HAZARD

The NO₂ converter operates at 315° C. Severe burns can result if the assembly is not allowed to cool.

Do not handle the assembly until it is at room temperature. This may take several hours.

4. Remove the tube fittings from the Moly converter assembly.
5. Disconnect the power and the thermocouple from the Moly converter assembly.
6. Unscrew the steel cable clamp (for the power leads) from the converter housing with a Phillips-head screw driver.
7. Remove the Moly converter assembly (converter cartridge and band heater) from the converter housing.
 - Make a note of the orientation of the tubes relative to the heater cartridge.
8. Unscrew the band heater and loosen it.
9. Remove the old converter cartridge.

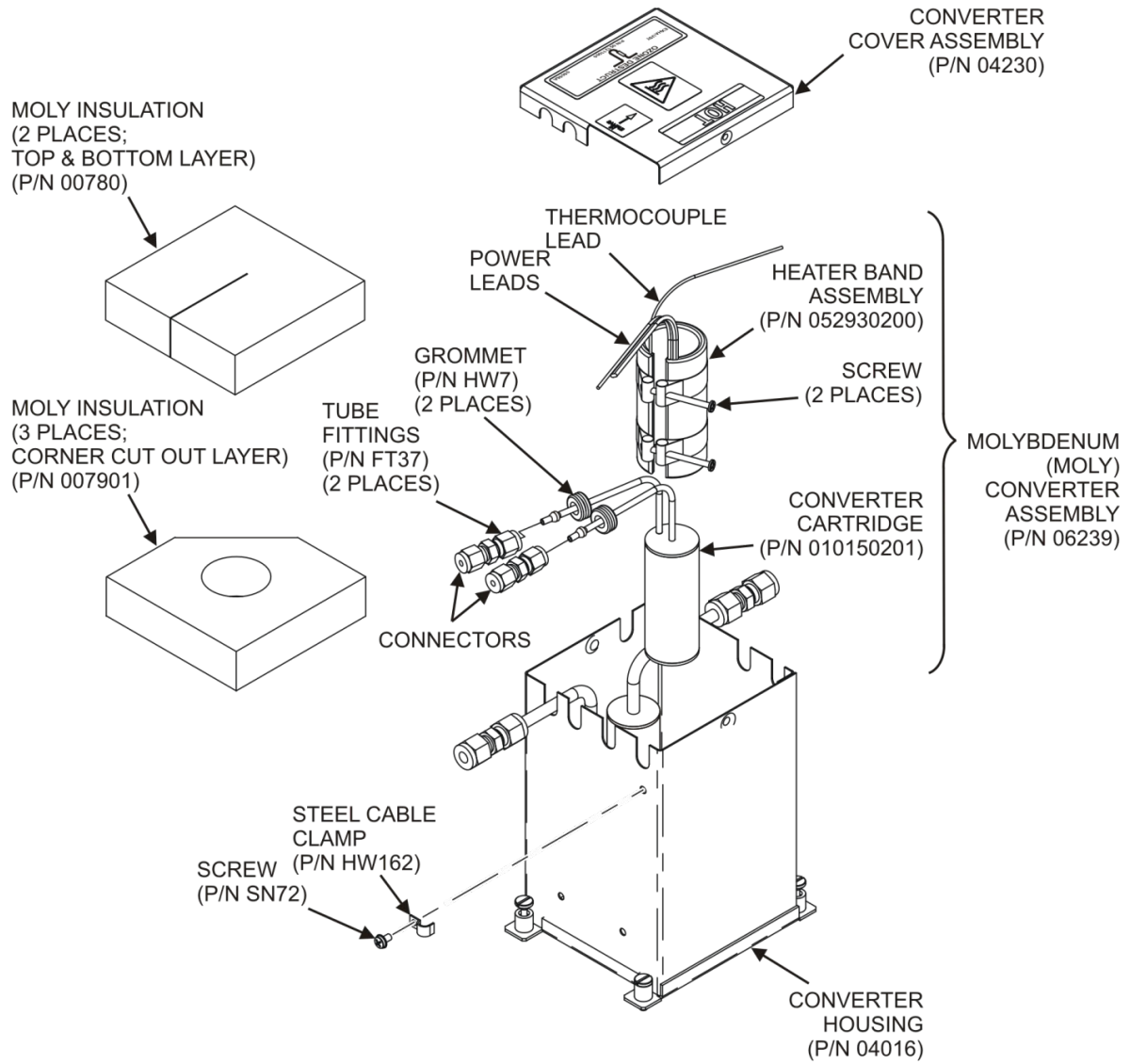

P/N 0187202G

Figure 5-12. NO₂ Converter Assembly

10. Wrap the band heater around the new replacement converter cartridge and tighten the screws using a high-temperature anti-seize agent such as copper paste.
 - Ensure to use proper alignment of the heater with respect to the converter tubes.
11. Replace the Moly converter assembly by routing the cables through the holes in the converter housing and reconnecting them properly.
12. Reconnect the steel cable clamp around the power leads for safe operation.
13. Reattach the tube fittings to the converter and replace the Moly insulation (top layer and corner cut out layers).
14. Reinstall the converter assembly cover.
15. Reinstall the instrument cover and power up the analyzer.
16. Allow the converter to burn-in for 24 hours, and then recalibrate the instrument.

5.6.7. CLEANING THE REACTION CELL

A dirty reaction cell will cause excessive noise, drifting zero or span values, low response or a combination of all.

To clean the reaction cell, it is necessary to remove it from the sensor housing. Refer to Figure 5-13 for the following procedure.

1. Turn off the instrument power and vacuum pump.
2. Disconnect the black 1/4" exhaust tube and the 1/8" sample and ozone air tubes from the reaction cell. Disconnect the heater/thermistor cable.
3. Remove two screws (Teledyne API P/N SN144) and two washers holding the reaction cell to the PMT housing and lift the cell and manifold out.

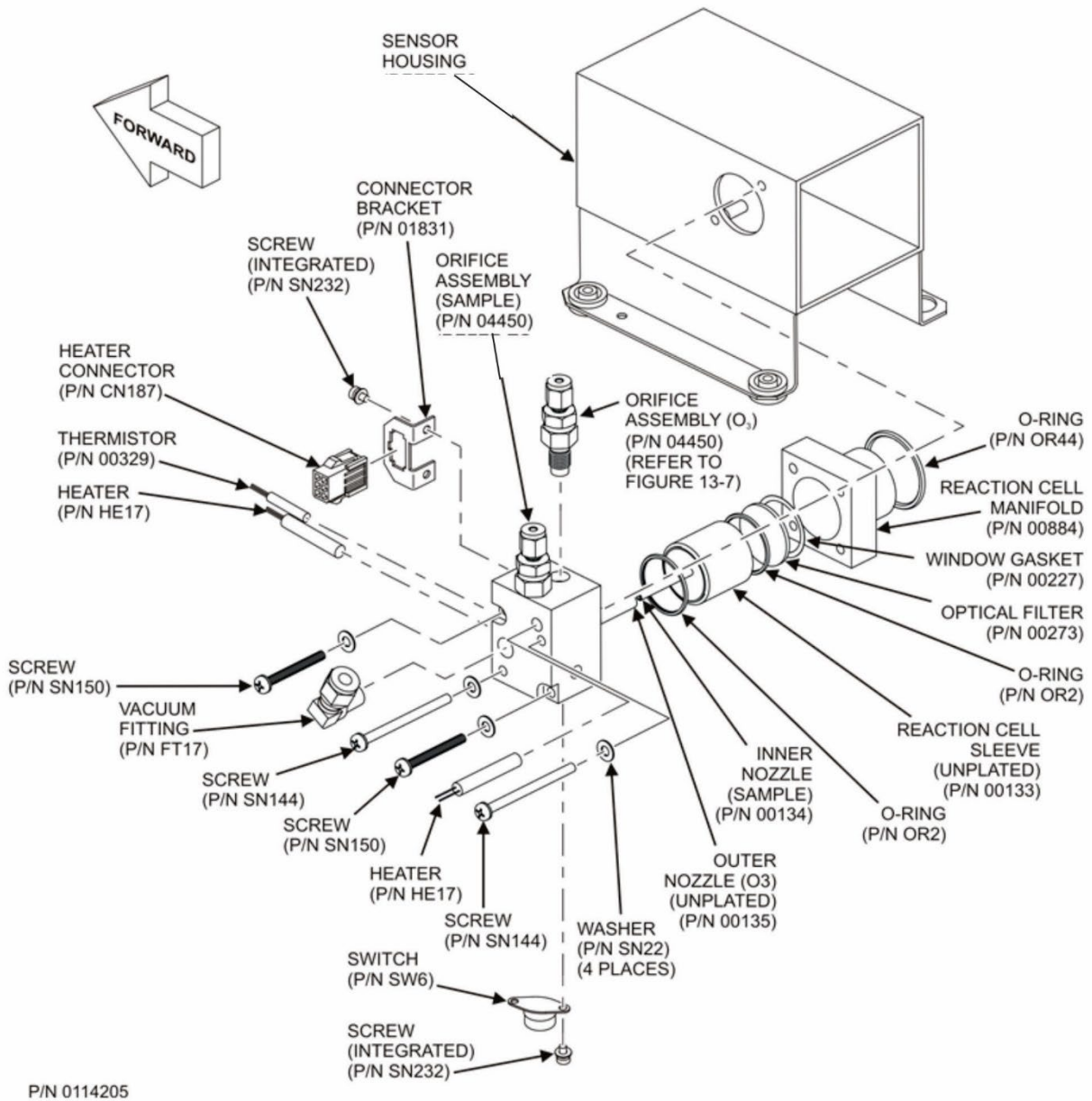

Figure 5-13. Reaction Cell Assembly

4. Remove two screws (Teledyne API P/N SN150) and two washers.
5. The reaction cell will separate into two halves, the stainless steel manifold assembly and the black plastic reaction cell with window gasket, stainless steel reaction cell sleeve, optical filter and O-rings.
6. The reaction cell (both plastic part and stainless steel sleeve) and optical filter should be cleaned with Distilled Water (DI - Water) and an appropriate optical wipe and then dried.
7. Usually it is not necessary to clean the sample and ozone flow orifices since they are protected by sintered filters.
 - If tests show that cleaning is necessary, refer to Section 5.6.8 on how to clean the critical flow orifice.
8. Do not remove the sample and ozone nozzles. They are Teflon threaded and require a special tool for reassembly. If necessary, the manifold with nozzles attached can be cleaned in an ultrasonic bath.
9. Reassemble in proper order and re-attach the reaction cell to the sensor housing. Reconnect pneumatics and heater connections, then re-attach the pneumatic sensor assembly and the cleaning procedure is complete.
10. After cleaning the reaction cell, it is also recommended to exchange the ozone supply air filter chemical as described in Section 5.6.4.
11. After cleaning, the analyzer span response may drop 10 - 15% in the first 10 days as the reaction cell window conditions. This is normal and does not require another cleaning.

5.6.8. SERVICING CRITICAL FLOW ORIFICES

There are several critical flow orifices installed in the analyzer (see Figure 6-6 for a pneumatic location of each orifice). Despite the fact that these flow restrictors are protected by sintered stainless steel filters, they can, on occasion, clog up, particularly if the instrument is operated without sample filter or in an environment with very fine, sub-micron particle-size dust.

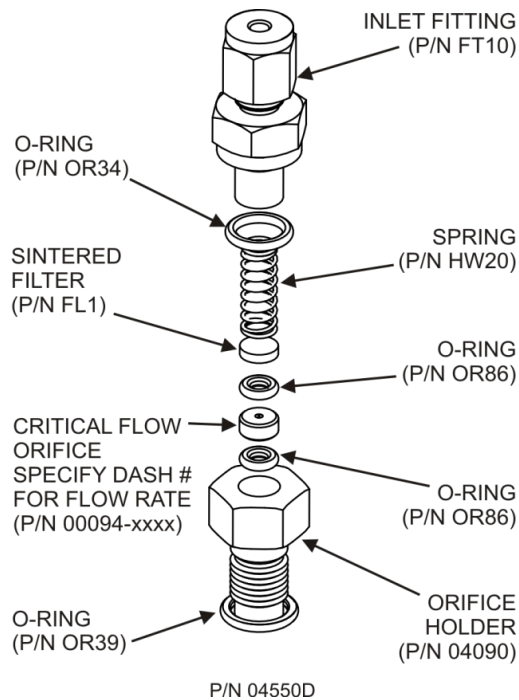

Figure 5-14. Critical Flow Orifice Assembly

To clean or replace a critical flow orifice:

1. Turn off power to the instrument and vacuum pump.
2. Remove the analyzer cover and locate the reaction cell assembly (refer to Figure 2-4 and Figure 5-13).
3. Unscrew the 1/8" sample and ozone air tubes from the reaction cell.

For orifices on the reaction cell:

4. Unscrew the orifice holder with a 9/16" wrench.
 - This part holds all components of the critical flow assembly as shown in Figure 5-14.

For orifices in the vacuum manifold: the assembly is similar to the one shown in Figure 5-14, except:

- Without the orifice holder, P/N 04090, and bottom O-ring, P/N OR34 and;
 - With an NPT fitting in place of the FT 10 fitting.
5. After taking off the connecting tube, unscrew the NPT fitting.
 6. Take out the components of the assembly:
 - spring
 - sintered filter
 - two O-rings
 - the orifice

Note

For the vacuum manifold only, you may need to use a scribe or pressure from the vacuum port to get the parts out of the manifold.

7. Discard the two O-rings and the sintered filter and install new ones.
8. Reassemble the parts as shown in Figure 5-14.
9. Reinstall the critical flow orifice assembly into the reaction cell manifold or the vacuum manifold.
10. Reconnect all tubing, power up the analyzer and pump. After a warm-up period of 30 minutes, carry out a leak test as described in Section 5.6.10.

5.6.9. CHECKING FOR LIGHT LEAKS

When re-assembled or operated improperly, the PMT assembly can develop small gaps, which let stray light from the analyzer surrounding into the PMT housing. To find such light leaks, follow the procedures below.



CAUTION – QUALIFIED PERSONNEL ONLY

This procedure is carried out with the analyzer running and its cover removed.

1. In the Dashboard view the **PMT Signal** (if not visible, configure the Dashboard to add; see Section 2.5.3).
2. Supply zero gas to the analyzer.
3. With the instrument still running, carefully remove the analyzer cover.



WARNING – ELECTRICAL SHOCK HAZARD

Do NOT touch any of the inside wiring with the metal cover or with your body.

Do NOT drop screws or tools into a running analyzer.

4. Shine a powerful flashlight or portable incandescent light at the inlet and outlet fitting and at all of the joints of the reaction cell as well as around the PMT housing.
 - The PMT value should not respond to the light, the PMT signal should remain steady within its usual noise floor.
5. If there is a PMT response to the external light, symmetrically tighten the reaction cell mounting screws or replace the 1/4" vacuum tubing with new, black PTFE tubing (this tubing will fade with time and become transparent).

Note

Often, light leaks are also caused by O-rings being left out of the assembly.

6. If, during this procedure, the black PMT housing end plate for the Sensor Assembly is removed, ensure to replace the 5 desiccant bags inside the housing.
7. Carefully replace the analyzer cover. If tubing was changed, carry out a pneumatic leak check (Section 5.6.10).

5.6.10. CHECKING FOR PNEUMATIC LEAKS

This Section covers a simple leak check and a detailed leak check.



CAUTION - TECHNICAL INFORMATION

Do not exceed 15 psi when pressurizing the system during either Simple or Detailed checks.

5.6.10.1. SIMPLE VACUUM LEAK AND PUMP CHECK

Leaks are the most common cause of analyzer malfunction. This Section presents a simple leak check, whereas the next Section details a more thorough procedure. The method described here is simple and quick and detects, but does not locate, most leaks. It also verifies the sample pump condition.

1. Turn the analyzer ON and allow at least 30 minutes for flows to stabilize.
2. Cap the sample inlet port (cap must be wrench-tight).
3. After several minutes, when the pressures have stabilized, note the Sample Press (sample pressure) and the Rx Cell Press (vacuum pressure) readings.
 - If both readings are equal to within 10% and less than 10 in-Hg-A, the instrument is free of large leaks.
 - It is still possible that the instrument has minor leaks.
 - If both readings are < 10 in-Hg-A, the pump is in good condition.
 - A new pump will create a pressure reading of about 4 in-Hg-A (at sea level).
4. When complete, switch off the pump and open the cap to the sample inlet port slowly to minimize inrush flow.

5.6.10.2. DETAILED PRESSURE LEAK CHECK

If a leak cannot be located by the above procedure, obtain a leak checker that contains a small pump, shut-off valve, and pressure gauge to create both over-pressure and vacuum. Alternatively, a tank of pressurized gas, with the two-stage regulator adjusted to ≤ 15 psi, a shutoff valve and a pressure gauge may be used.

Note

The analyzer and the 501 each require their own separate leak checks.

ATTENTION

COULD DAMAGE INSTRUMENT AND VOID WARRANTY

Once tube fittings have been wetted with soap solution under a pressurized system, do not apply or reapply vacuum as this will cause soap solution to be sucked into the instrument, contaminating inside surfaces.

1. Turn OFF power to the instrument and remove the instrument cover.
2. Install a leak checker or a tank of gas (compressed, oil-free air or nitrogen) as described above on the sample inlet at the rear panel.
3. Disconnect the pump tubing on the outside rear panel and cap the pump port.
 - If IZS or zero/span valves are installed, disconnect the tubing from the zero and span gas ports and plug the ports.
 - Cap the DFU particle filter on the dryer.

4. Pressurize the instrument with the leak checker or tank gas, allowing enough time to fully pressurize the instrument through the critical flow orifice.
 - Check each tube connection (fittings, hose clamps) with soap bubble solution, looking for fine bubbles.
 - Once the fittings have been wetted with soap solution, do not reapply vacuum as it will draw soap solution into the instrument and contaminate it.
 - Do not exceed 15 psi pressure.
5. If the instrument has the zero and span valve option, the normally closed ports on each valve should also be separately checked.
 - Connect the leak checker to the normally closed ports and check with soap bubble solution.
6. If the analyzer is equipped with an IZS Option, connect the leak checker to the Dry Air inlet and check with soap bubble solution.
7. Once the leak has been located and repaired, the leak-down rate of the indicated pressure should be less than 1 in-Hg-A (0.4 psi) in 5 minutes after the pressure is turned off.
8. Clean surfaces from soap solution, reconnect the sample and pump lines and replace the instrument cover.
9. Restart the analyzer.

5.6.10.3. PERFORMING FLOW CHECKS/CALIBRATIONS

Important

IMPACT ON READINGS OR DATA

Use a separate, calibrated flow meter capable of measuring the flow specifications for the instrument being checked/calibrated in order to get accurate measurements. Do not use the built in flow measurement viewable in the Dashboard. This value is only calculated, not measured.

The rates of sample gas flow and O₃ flow through the analyzer are a key part of the concentration readings, but the readings are only calculated values derived by the CPU. The (sample) Flow Cal and Ozone Flow Cal features under the Utilities>Diagnostics menu are used to check and to calibrate/adjust these calculations.

Such checks are useful for monitoring the actual flow of the instrument, using an external flow meter. A decreasing, actual sample flow may point to slowly clogging pneumatic paths, most likely critical flow orifices or sintered filters (Section 5.6.8).

FLOW CHECK (SAMPLE AND/OR OZONE)

Low flows indicate blockage somewhere in the pneumatic pathway.

To check the Sample flow with the external flow meter:

1. Disconnect the sample inlet tubing from the rear panel SAMPLE port.
2. Attach the outlet port of a suitable flow meter to the rear panel SAMPLE port.
 - Ensure that the inlet to the flow meter is at atmospheric pressure.
3. The sample flow measured with the external flow meter should be within $\pm 10\%$ of the analyzer's Flow specification (Table 1-1).

To check the Ozone flow with the external flow meter:

1. Open the analyzer to gain access to the reaction cell.
2. Disconnect the tube going to the reaction cell's 4 mil fitting.
3. Connect the flow meter to the reaction cell's 4 mil fitting.
4. The ozone flow measured with the external flow meter should be 80 cc/min.

FLOW CALIBRATION (SAMPLE AND/OR OZONE)

To calibrate the Sample flow (Flow Cal) or the O₃ flow (Ozone Flow Cal):

1. In the Utilities>Diagnostics>Flow Cal or Ozone Flow Cal menu (Figure 5-15), edit the Actual Flow value by inputting the reading from the external flow meter obtained in the corresponding check of the flow to be calibrated.
2. Press the Calibrate button.

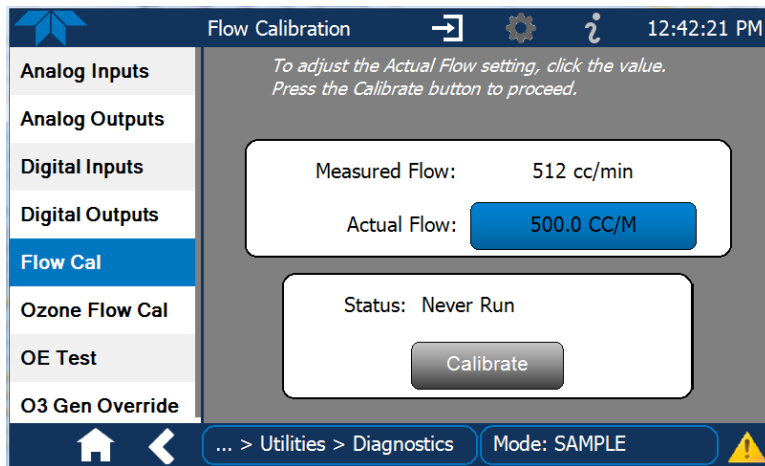

Figure 5-15. Flow Calibration Menu

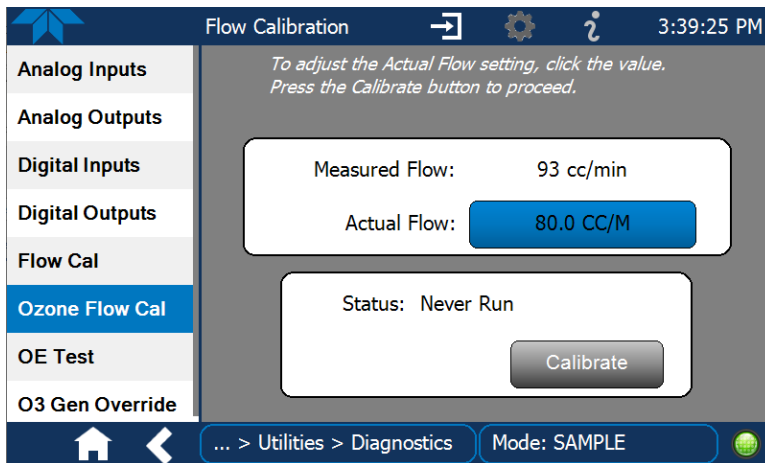

Figure 5-16. Ozone Flow Calibration Menu

5.7. SERVICE AND TROUBLESHOOTING

This Section contains methods to identify the source of performance problems with the analyzer and procedures to service the instrument.

Note

Section 6, Principles of Operation, provides information about how the instrument works, to support your understanding of the technical details of maintenance.



CAUTION

The operations outlined in this Section must be performed by qualified maintenance personnel only.



WARNING – RISK OF ELECTRICAL SHOCK

Some operations need to be carried out with the analyzer open and running.

Exercise caution to avoid electrical shocks and electrostatic or mechanical damage to the analyzer.

Do not drop tools into the analyzer or leave them after your procedures.

Do not short or touch electric connections with metallic tools while operating inside the analyzer.

Use common sense when operating inside a running analyzer.

The analyzer has been designed so that problems can be rapidly detected, evaluated and repaired. During operation, it continuously performs diagnostic tests and provides the ability to evaluate its key operating parameters without disturbing monitoring operations.

A systematic approach to troubleshooting will generally consist of the following five steps:

1. Note any Alerts and take corrective action as necessary (see Table 5-4).
2. Examine the values of all basic functions in the Dashboard and compare them to factory values. Note any major deviations from the factory values and take corrective action.
3. Use the internal electronic status LEDs to determine whether the electronic communication channels are operating properly.
 - Verify that the DC power supplies are operating properly by checking the voltage test points on the relay PCA.
 - Note that the analyzer's DC power wiring is color-coded and these colors match the color of the corresponding test points on the relay PCA.

4. Suspect a leak first!
 - Customer service data indicate that the majority of all problems are eventually traced to leaks in the internal pneumatics of the analyzer or the diluent gas and source gases delivery systems.
 - Check for gas flow problems such as clogged or blocked internal/external gas lines, damaged seals, punctured gas lines, damaged / malfunctioning pumps, etc.

5. Follow the procedures defined in Section 2.3.4.3 to confirm that the analyzer's vital functions are working (power supplies, CPU, relay PCA, touchscreen, PMT cooler, etc.).

5.7.1. FAULT DIAGNOSIS WITH ALERTS

Table 5-4 lists brief descriptions of warning Alerts that may occur during start up and describes their possible causes for diagnosis and trouble shooting..

It should be noted that if more than two or three warning Alerts occur at the same time, it is often an indication that some fundamental sub-system (power supply, relay PCA, motherboard) has failed rather than an indication of the specific failures referenced by the warnings.

Table 5-4. Warning Alerts, Fault Conditions and Possible Causes

WARNING	FAULT CONDITION	POSSIBLE CAUSES
AUTO ZERO WARN XXX.X MV	AutoZero reading too high. (Auto-zero reading above 200 mV). Value shown in message indicates auto-zero reading at time warning was displayed.	AUTO ZERO valve not working Valve control driver failed Bad Relay PCA Failed +12 VDC power supply Gas leak across AUTO ZERO Valve ports Dirty Reaction Cell O ₃ flow problem to RCELL
BOX TEMP WARNING	Temperature of chassis is outside specified limits. (typically < 7°C or > 48°C)	Box Temperature typically runs ~7°C warmer than ambient temperature Poor/blocked ventilation to the analyzer Stopped Exhaust-Fan Ambient Temperature outside of specified range
CANNOT DYN SPAN ²	Dynamic Span operation failed. (Contact closure span calibration failed while <i>DYN_SPAN</i> was set to <i>ON</i>).	Measured concentration value is too high or low Concentration Slope value to high or too low
CANNOT DYN ZERO ³	Dynamic Zero operation failed. (Contact closure zero calibration failed while <i>DYN_ZERO</i> was set to <i>ON</i>).	Measured concentration value is too high Concentration Offset value to high
CONFIG INITIALIZED	Configuration and Calibration data reset to original Factory state or erased.	Failed Disk on Module User erased data

WARNING	FAULT CONDITION	POSSIBLE CAUSES
CONV TEMP WARNING	NO ₂ to NO converter temperature too high or too low to efficiently convert NO ₂ to NO. (NO ₂ to NO converter temperature < 305°C or > 325°C).	Heater configured for wrong voltage type Failed converter Temperature Sensor Relay controlling the Heater is not working Failed Relay Board
DATA INITIALIZED	Data Storage in DAS was erased before the last power up occurred.	Failed Disk-on-Module User cleared data.
HVPS WARNING	High voltage power supply output is too high or too low for proper operation of the PMT. (Outside of warning limits).	No +15 VDC power supply to Preamplifier PCA Drive voltage not adjusted properly Failed PMT Preamplifier PCA Dirty reaction cell Bad pneumatic flow
OZONE FLOW WARNING	Ozone gas flow is too high or too low for accurate gas concentration readings. (O ₃ flow rate < 50 cc/min or > 150 cc/min).	Failed Sample Pump Blocked O ₃ dryer Blocked inlet/outlet to O ₃ purifier Dirty O ₃ dryer DFU Leak downstream of RCELL Failed O ₃ Flow Sensor
OZONE GEN OFF ⁴	Ozone generator is off. This is the only warning message that automatically clears itself. It clears itself when the ozone generator is turned on. Upon power up the Ozone generator will remain off for 30 minutes, which allows the ozone dryer to reach its working dew point.	O ₃ generator override is turned ON. Electrical connection between motherboard and generator is faulty. Bad +15VDC power supply
PMT TEMP WARNING	PMT temperature outside of warning limits. (Sample temperature is < 5°C or > 12°C).	PMT fan not operating Failed PMT Temperature Sensor TEC not functioning Failed PMT Preamp PCA
RCELL PRESS WARN	Reaction cell pressure is too high or too low for accurate gas concentration readings. (RCELL pressure is < 0.5 in-Hg or >15 in-Hg). Nominal range 4-7 in-Hg.	Pump may not be functioning properly, Or if Reaction Cell Pressure is < 0.5 in-Hg: <ul style="list-style-type: none"> •Blocked Particulate Filter •Blocked Sample Inlet/Gas Line •Failed Pressure Sensor/circuitry If Sample Pressure is > 15 in-Hg: <ul style="list-style-type: none"> •Blocked vacuum manifold •Broken Ozone Dryer
RCELL TEMP WARN	Reaction cell temperature is too high or too low for accurate gas concentration readings. (RCELL temperature is < 45°C or > 55°C).	Heater configured for wrong voltage type Failed RCELL Temperature Sensor Relay controlling the heater is not working Failed Relay Board I ² C Bus
REAR BOARD NOT DET	Motherboard not detected on power up. (CPU unable to communicate with motherboard).	This warning only appears on Serial I/O COM Port(s). Front panel display will be frozen, blank or will not respond. Failure of motherboard
RELAY BOARD WARN	The CPU unable to communicate with the Relay PCA.	I ² C Bus failure Failed Relay Board Loose connectors/wiring

WARNING	FAULT CONDITION	POSSIBLE CAUSES
SAMPLE FLOW WARN	The flow rate of the sample gas is outside the specified limits. (Sample flow rate is < 350 cc/min or > 600 cc/min).	Failed Sample Pump Blocked Sample Inlet/Gas Line Dirty Particulate Filter Leak downstream of RCELL Critical Flow Orifice Failed Sample Pressure Sensor Failed Vacuum Pressure Sensor
SAMPLE PRESS WARN	Sample pressure is too high or too low for accurate readings. (Sample Pressure is <15 in-Hg or > 35 in-Hg). Normally 29.92 in-Hg at sea level decreasing at 1 in-Hg per 1000 ft of altitude (with no flow – pump disconnected).	If Sample Pressure is < 15 in-Hg: •Blocked Particulate Filter •Blocked Sample Inlet/Gas Line •Failed Pressure Sensor/circuitry If Sample Pressure is > 35 in-Hg: •Bad Pressure Sensor/circuitry •Pressure too high at Sample Inlet.
SYSTEM RESET	The computer has rebooted.	This message occurs at power on. If it is confirmed that power has not been interrupted: Failed +5 VDC power Fatal Error caused software to restart Loose connector/wiring

- ¹ Clears 45 minutes after power up.
- ² Clears the next time successful zero calibration is performed.
- ³ Clears the next time successful span calibration is performed.
- ⁴ Clears 30 minutes after power up.
- ⁵ Only appears if the IZS option is installed.

5.7.2. FAULT DIAGNOSIS WITH DASHBOARD FUNCTIONS

In addition to being useful as predictive diagnostic tools, the functions viewable in the Dashboard can be used to isolate and identify many operational problems when combined with a thorough understanding of the analyzer's principles of operation (see Section 6).

The acceptable ranges for these functions are listed in the "Nominal Range" column of the analyzer *Final Test and Validation Data Sheet* shipped with the instrument. Values outside these acceptable ranges indicate a failure of one or more of the analyzer's subsystems. Functions whose values are still within acceptable ranges but have significantly changed from the measurement recorded on the factory data sheet may also indicate a failure.

Make note of these values for reference in troubleshooting.

Note

If no value displays for any of these Dashboard functions, it indicates an OUT OF RANGE reading.

Note

Sample Pressure measurements are represented in terms of "Absolute Atmospheric Pressure" because this is the least ambiguous method for reporting gas pressure. Absolute atmospheric pressure is about 29.92 in-Hg-A at sea level. It decreases about 1 in-Hg per 1000 ft gain in altitude. A variety of factors such as air conditioning systems, passing storms, and air temperature, can also cause changes in the absolute atmospheric pressure.

Table 5-5. Dashboard Functions - Indicated Failures

DASHBOARD FUNCTION	INDICATED FAILURE(S)
Stability	Unstable concentrations; leaks
Sample Flow	Leaks; clogged critical flow orifice
O3 Flow	Leaks; clogged critical flow orifice
PMT Signal	Calibration off; HVPS problem; no flow (leaks)
Normalized PMT	Auto Zero too high
Auto Zero	Leaks; malfunctioning NO, NO _x , TN _x or Auto Zero valve; O ₃ air filter cartridge exhausted
HVPS	Calibration off; preamp board circuit problems
Rx Cell Temp	Malfunctioning heater; relay board communication (I ² C bus); relay burnt out
Box Temp	Environment out of temperature operating range; broken thermistor
PMT Temp	TEC cooling circuit broken; relay board communication (I ² C bus); 12 V power supply
I _{ZS} Temp (option)	Malfunctioning heater; relay board communication (I ² C bus); relay burnt out
Moly Temp	Malfunctioning heater; disconnected or broken thermocouple; relay board communication (I ² C bus); relay burnt out; incorrect AC voltage configuration
Rx Cell Press	Leak; malfunctioning valve; malfunctioning pump; clogged flow orifices
Sample Pressure	Leak; malfunctioning valve; malfunctioning pump; clogged flow orifices; sample inlet overpressure
NO _x Slope	HVPS out of range; low-level (hardware) calibration needs adjustment; span gas concentration incorrect; leaks
NO _x Norm Offset	Incorrect span gas concentration; low-level calibration off
NO Slope	HVPS out of range; low-level calibration off; span gas concentration incorrect; leaks
NO Norm Offset	Incorrect span gas concentration; low-level calibration off
TN _x Slope	HVPS out of range; low-level (hardware) calibration needs adjustment; span gas concentration incorrect; leaks
TN _x Norm Offset	Incorrect span gas concentration; low-level calibration off

5.7.3. USING THE DIAGNOSTIC SIGNAL I/O FUNCTIONS

The signal I/O functions in the Utilities>Diagnostics menu allows access to the digital and analog I/O in the analyzer. Some of the digital signals can be controlled through the Setup menu. These signals, combined with a thorough understanding of the instrument’s principles of operation (Section 6), are useful for troubleshooting in three ways:

- The technician can view the raw, unprocessed signal level of the analyzer’s critical inputs and outputs.
- Many of the components and functions that are normally under algorithmic control of the CPU can be manually exercised.
- The technician can directly control the signal level Analog and Digital Output signals.

This allows the technician to observe systematically the effect of directly controlling these signals on the operation of the analyzer. Use the Utilities>Diagnostics menu to view the raw voltage of an input signal or the Setup menu to control the state of an output voltage or control signal.

5.7.4. USING THE ANALOG OUTPUT CHANNELS

Signals available for output over the analyzer's analog output channel (configured in the Setup>Analog Outputs menu; see Section 2.5.8) can also be used as diagnostic tools through the Utilities>Diagnostics menu. Some of the outputs and their descriptions and causes are presented in Table 5-6.

Table 5-6. Analog Outputs as Diagnostic Tools

TEST CHANNEL	DESCRIPTION	ZERO	FULL SCALE	CAUSES OF EXTREMELY HIGH / LOW READINGS
PMT	The output of the PMT detector converted to a 0 to 5 VDC scale.	0 mV	5000 mV	Failed PMT PMT Temperature too High/Low Bad PMT Preamp PCA Failed HVPS Misadjusted HVPS drive Voltage Light Leak in reaction cell
O3 Flow	The flow rate of O ₃ through the analyzer as measured by the O ₃ flow sensor	0 cm ³ /min	1000 cm ³ /min	Check for Gas Flow problems in the O ₃ gas lines.
Sample Flow	The calculated flow rate for sample gas through the analyzer.	0 cm ³ /min	1000 cm ³ /min	Check for Gas Flow problems in the sample gas lines.
Sample Press	The pressure of the sample gas measured upstream of the Auto Zero Valve	0 In-Hg-A	40 In-Hg-A	Check for Gas Flow problems in the sample gas lines.
Rx Cell Press	The pressure of gas inside the reaction cell of the sensor module	0 In-Hg-A	40 In-Hg-A	Check for Gas Flow problems in all gas lines.
Rx Cell Temp	The temperature of gas inside the reaction cell of the sensor module	0 °C	70 °C	Heater configured for wrong voltage type Failed RCELL Temperature Sensor Relay controlling the heater is not working Failed Relay Board I ² C Bus
PMT Temp	The temperature inside PMT	0 °C	50 °C	PMT fan not operating Failed PMT Temperature Sensor TEC not functioning Failed PMT Preamp PCA
Box Temp	The temperature inside the analyzer's chassis	0 °C	70 °C	Box Temperature typically runs ~7°C warmer than ambient temperature Poor/blocked ventilation to the analyzer Stopped Exhaust-Fan Ambient Temperature outside of specified range

5.7.5. USING THE INTERNAL ELECTRONIC STATUS LEDs

Several LEDs are located inside the instrument to assist in determining if the analyzer's CPU, I²C bus and Relay PCA are functioning properly.

5.7.5.1. CPU STATUS INDICATOR

DS5, a red LED located on the motherboard (Figure 5-17), flashes when the CPU is running the main program loop. After power-up, approximately 30 – 60 seconds, DS5 should flash on and off. If the front panel displays properly but DS5 does not flash, then the program files have become corrupted, contact Teledyne API's Technical Support Department (see Section 5.9) because it may be possible to recover operation of the analyzer. If after 30 – 60 seconds, neither DS5 is flashing nor does the front panel display properly then the CPU is bad and must be replaced.

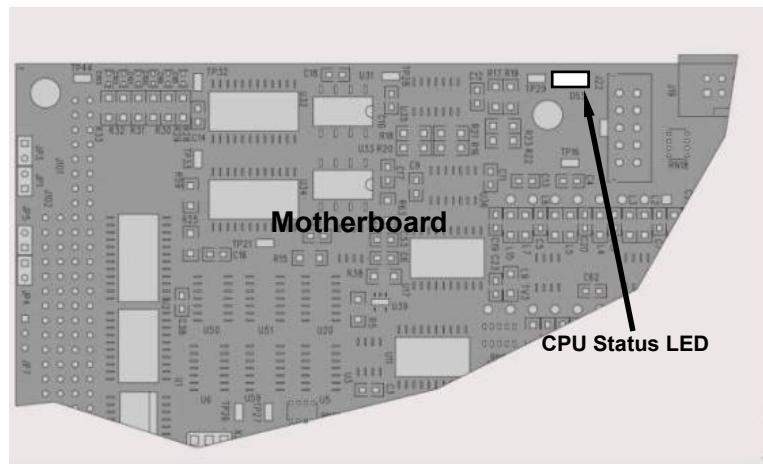

Figure 5-17. CPU Status Indicator

5.7.5.2. RELAY PCA WATCHDOG AND STATUS LEDS

There are sixteen LEDs located on the Relay PCA (some are not used on this model). The most important of the LEDs is D1, which indicates the health of the I²C bus.

RELAY PCA STATUS LEDS

LEDs and their respective components are described in Table 5-7.

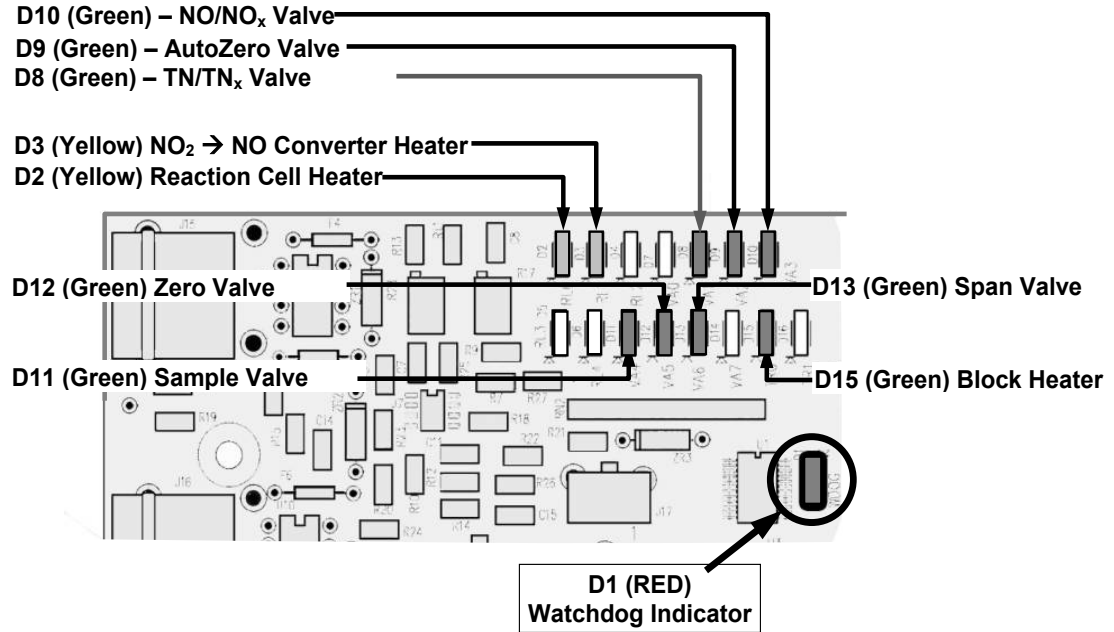

Figure 5-18. Relay PCA Status LEDS Used for Troubleshooting

Table 5-7. Relay PCA Watchdog and Status LED Descriptions and Failure Indications

LED	TYPICAL STATUS BEHAVIORS		POSSIBLE CAUSES IF FAILURE OCCURS
	LIT (ON)	NOT LIT (OFF)	
D1 (red) I ² C bus Health (Watchdog Circuit)	Cycles ON/OFF (blinks) every 3 seconds under direct control of the analyzer's CPU. When solid lit ON or solid OFF for 30 seconds, the CPU or I ² C bus has stopped functioning, this Watchdog Circuit automatically shuts all valves and turns off all heaters.		Failed/Halted CPU. Faulty Motherboard, Touchscreen or Relay PCA. Faulty Connectors/Wiring between Motherboard, Touchscreen or Relay PCA. Failed/Faulty +5 VDC Power Supply (PS1).
D2 (yellow) Reaction cell heater	Reaction cell heater is heating	Not Heating	Heater broken or disconnected; thermistor broken or disconnected; or bad Relay AC
D3 (yellow) NO ₂ converter heater	Converter heater is heating	Not Heating	Heater broken or disconnected; thermocouple broken or disconnected; bad thermal switch; or bad Relay AC
D8 (green) TN _x valve	TN/TN _x valve: gas flow routed THROUGH the 501 converter	Gas Flow BYPASSES the converter	Valve broken or stuck; valve driver chip broken
D9 (green)	A/Z valve: sample gas flow BYPASSES the reaction cell	Sample gas flow is routed THROUGH the reaction cell	Valve broken or stuck; valve driver chip broken

LED	TYPICAL STATUS BEHAVIORS		POSSIBLE CAUSES IF FAILURE OCCURS
	LIT (ON)	NOT LIT (OFF)	
Auto-zero valve			
D10 (green) NO/NO _x valve	NO/NO _x valve: gas flow routed THROUGH the converter	Gas Flow BYPASSES the converter	Valve broken or stuck; valve driver chip broken
D11 (green) Sample valve	Sample valve: OPEN to Sample gas inlet	OPEN to SPAN2 inlet	Valve broken or stuck; valve driver chip broken
D12 (green) Zero valve	Zero valve: OPEN to Zero Air inlet	Zero gas flow OPEN	Valve broken or stuck; valve driver chip broken
D13 (green) Span valve	Span valve: Span gas flow SHUTOFF	Span gas flow OPEN	Valve broken or stuck; valve driver chip broken
D15 (green) Block heater	Block heater is heating	Not Heating	Heater broken or disconnected; thermistor broken or disconnected; or bad Relay AC

5.7.6. FLOW PROBLEMS

The analyzer has two main flow paths, the sample flow and the flow of the ozone supply air. With the Zero/Span valve option installed, there is a third (zero air) and a fourth (span gas) flow path, but either one of those is only controlled by critical flow orifices and not displayed on the front panel or stored to the DAS.

In the two main flow paths, flow problems occur in the following three ways:

- Flow is zero or low
- Flow is too high
- Flow is greater than zero, but is too low, and/or unstable

When troubleshooting flow problems, it is essential to confirm the actual flow rate without relying on the analyzer's flow display. The use of an independent, external flow meter to perform a flow check as described in Section 5.6.10.3 is essential. Refer to the pneumatic flow diagrams as needed for reference.

5.7.6.1. SAMPLE FLOW IS ZERO OR LOW

The analyzer does not actually measure the sample flow but rather calculates it from a differential pressure between sample and vacuum manifold. On flow failure, the unit will display a SAMPLE FLOW WARNING in the Active Alerts page and the respective function reports nothing instead of a numerical value. This message applies to both a flow rate of zero as well as a flow that is outside the standard range (350-600 cc/min).

If the analyzer displays nothing for the sample flow, confirm that the external sample pump is operating and configured for the proper AC voltage.

- Whereas the analyzer can be internally configured for two different power regimes (100-120 V and 220-240 V, either 50 or 60 Hz), the external pump is physically

different for each of three power regimes (100 V / 50 Hz, 115 V / 60 Hz and 230 V / 50 Hz).

- If the pump is not running, use an AC Voltmeter to ensure that the pump is supplied with the proper AC power. If AC power is supplied properly, but the pump is not running, replace the pump.

Note

Sample and vacuum pressures mentioned in this chapter refer to operation of the analyzer at sea level. Pressure values need to be adjusted for elevated locations, as the ambient pressure decreases by about 1 in-Hg per 300 m / 1000 ft.

If the pump is operating but the unit is not reporting gas flow value, take the following three steps:

1. Check for actual sample flow.
 - To check the actual sample flow, disconnect the sample tube from the external 501 sample inlet .
 - Ensure that the unit is in basic SAMPLE mode.
 - Place a finger over the inlet and feel for suction by the vacuum or, more properly, use a flow meter to measure the actual flow.
 - If there is no flow or low flow, continue with the next step.
2. Check pressures.
 - Check that the sample pressure is at or around 28 in-Hg-A at sea level (adjust as necessary when in elevated location, the pressure should be about 1" below ambient atmospheric pressure) and that the Rx Cell pressure is below 10 in-Hg-A.
 - The analyzer will calculate a sample flow up to about 14 in-Hg-A RCEL pressure but a good pump should always provide less than 10 in-Hg-A.
 - If both pressures are the same and around atmospheric pressure, the pump does not operate properly or is not connected properly. The instrument does not get any vacuum.
 - If both pressures are about the same and low (probably under 10 in-Hg-A, or ~20" on sample and 15" on vacuum), there is a cross-leak between sample flow path and vacuum, most likely through the dryer flow paths. Check for leaks (Section 5.6.10).
 - If the sample and vacuum pressures are around their nominal values (28 and <10 in-Hg-A, respectively) and the flow still displays no numerical value, carry out a leak check as described in Section 5.6.10.
 - If gas flows through the instrument during the above tests but goes to zero or is low when it is connected to zero air or span gas, the flow problem is not internal to the analyzer but likely caused by the gas source such as calibrators/generators, empty gas tanks, clogged valves, regulators and gas lines.
 - If the Zero/Span valve option is installed in the instrument, press Start in the Calibration>Zero and Span menus. If the sample flow increases, suspect a bad Sample/Cal valve.

3. If none of these suggestions help, carry out a detailed leak check of the analyzer as described in Section 5.6.10.2.

5.7.6.2. OZONE FLOW IS ZERO OR LOW

If there is zero or a low (<50 cc/min) ozone flow, the unit displays an OZONE FLOW WARNING message in the Alerts page and a value between 0.0 and 50 cc/min for the actual ozone flow as measured by the internal mass flow meter. In this case, carry out the following steps:

- Check the actual flow rate through the ozone dryer by using an external flow meter to the inlet port of the dryer.
 - This inlet port is inside the analyzer at the end of the plastic particle filter (Section 5.6.1 for illustration).
 - If there is nominal flow (about 160 cc/min from 80 cc/min O₃ flow and 80 cc/min purge flow), consult customer service as there is a problem with the firmware or electronics.
 - If the actual flow is low or zero, check if the pump operates properly. The RCEL pressure should be below 10 in-Hg-A at sea level.
 - If it is above 10 in-Hg-A, rebuild the pump (Section 5.6.5.1). Call Tech Support to order pump rebuild kits.
- Check if the particle filter is clogged.
 - Briefly remove the particle filter to see if this improves the flow.
 - Be very cautious when handling the dryer fittings (see Section 5.6.1 on proper handling instructions).
 - If the filter is clogged, replace it with a new unit.
 - If taking off this filter does not solve the problem, continue to the next step.
 - Do not leave the dryer without filter for more than a few seconds, as you may draw in dust, which will reduce the performance of the dryer.
- A leak between the flow meter and the reaction cell (where the flow-determining critical orifice is located) may cause a low flow (the system draws in ambient air through a leak after the flow meter).
 - Check for leaks as described in Section 5.6.10.
 - Repair the leaking fitting, line or valve and re-check.
- The most likely cause for zero or low ozone flow is a clogged critical flow orifice or sintered filter within the orifice assembly.
 - The orifice that sets the ozone flow is located on the reaction cell.
 - Check the actual ozone flow by disconnecting the tube from the reaction cell and measuring the flow going into the cell.
 - If this flow is correct (~80 cc/min), the orifice works properly.
 - If this flow is low, replace the sintered filter.
 - The orifice holder assembly allows a quick and easy replacement of the filter (Section 5.6.8).

5.7.6.3. SAMPLE FLOW TOO HIGH

Flow readings that are significantly higher than the allowed operating range (typically ± 10 - 11% of the nominal flow) should not occur in the analyzer unless a pressurized sample, zero or span gas is supplied to the inlet ports.

- Ensure to vent excess pressure and flow just before the analyzer inlet ports.
- When supplying sample, zero or span gas at ambient pressure, a high flow could indicate a broken critical flow orifice (very unlikely case), allowing more than nominal flow, or were replaced with an orifice of wrong specifications.
- If the flows are within 15% above normal, we recommend measuring and recalibrating the flow electronically (Section 5.6.10.3), followed by a regular review of these flows over time to see if the new setting is retained properly.
- Also, check the flow assembly o-rings and replace as needed.

5.7.6.4. SAMPLE FLOW IS ZERO OR LOW BUT ANALYZER REPORTS CORRECT FLOW

The analyzer can report a correct flow rate even if there is no or a low actual sample flow through the reaction cell.

- The sample flow is only calculated from the sample pressure and critical flow condition is verified from the difference between sample pressure and vacuum pressure.
- If the critical flow orifice assembly is partially or completely clogged, both the sample and vacuum pressures are still within their nominal ranges (the pump keeps pumping, the sample port is open to the atmosphere), but there is no flow possible through the reaction cell.

Although measuring the actual flow is the best method, in most cases, this fault can also be diagnosed by evaluating the two pressure values.

- Since there is no longer any flow, the sample pressure should be equal to ambient pressure, which is about 1 in-Hg-A higher than the sample pressure under normal operation.
- The reaction cell pressure, on the other hand, is significantly lower than under normal operation, because the pump no longer has to evacuate 500 cc/min of sample gas and evacuates the reaction cell much better.
- Those two indicators, taken together with a zero or low actual flow, indicate a clogged sample orifice.

The analyzer features a new orifice holder, which makes switching sample and ozone flow orifices very easy; refer to Section 5.6.8 on how to change the sample orifices.

Again, monitoring the pressures and flows regularly will reveal such problems, because the pressures would slowly or suddenly change from their nominal, mean values. Teledyne API recommends reviewing all test data once per week and to do an exhaustive data analysis for test and concentration values once per month, paying particular attention to sudden or gradual changes in all parameters that are supposed to remain constant, such as the flow rates.

5.7.7. CALIBRATION PROBLEMS

This Section describes possible causes of calibration problems.

5.7.7.1. NEGATIVE CONCENTRATIONS

Negative concentration values can have any of several causes:

- A slight, negative signal is normal when the analyzer is operating under zero gas and the signal is drifting around the zero calibration point.
 - This is caused by the analyzer's zero noise and may cause reported concentrations to be negative for a few seconds at a time down to -20 ppb, but should randomly alternate with similarly high, positive values.
 - The analyzer has a built-in Auto Zero function, which should take care of most of these deviations from zero, but may yield a small, residual, negative value.
 - If larger, negative values persist continuously, check if the Auto Zero feature is functioning.
 - In this case, the sensitivity of the analyzer may be drifting negative.
- A corruption of the Auto Zero filter may also cause negative concentrations.
 - If a short, high noise value was detected during the Auto Zero cycle, that higher reading will alter the Auto Zero filter value.
 - As the value of the Auto Zero filter is subtracted from the current PMT response, it will produce a negative concentration reading.
 - High Auto Zero readings can be caused by:
 - a leaking or stuck Auto Zero valve (replace the valve),
 - an electronic fault in the preamplifier causing it to have a voltage on the PMT output pin during the Auto Zero cycle (replace the preamplifier),
 - a reaction cell contamination causing high background (>40 mV) PMT readings (clean the reaction cell),
 - a broken PMT temperature control circuit, allowing high zero offset (repair the faulty PMT cooler). After fixing the cause of a high Auto Zero filter reading, allow 15 minutes for the filter to clear itself, or
 - an exhausted chemical in the ozone cleanser (see Section 5.6.4).
- Calibration error is the most likely explanation for negative concentration values.
 - If the zero air contained some NO or NO₂ or NH₃ gas (contaminated zero air or a worn-out zero air scrubber) and the analyzer was calibrated to that concentration as "zero", the analyzer may report negative values when measuring air that contains little or no NO_x/ NH₃.
 - The same problem occurs if the analyzer was zero-calibrated using zero gas that is contaminated with ambient air or span gas (valve cross-port leaks or leaks in supply tubing or user not waiting long enough to flush pneumatic systems).
- If the response offset for NO (NO OFFSET) or NO_x (NOX OFFSET) or TNO_x (TNX OFFSET) are greater than 150 mV, a reaction cell contamination is indicated.
 - Clean the reaction cell as described in Section 5.6.7.

5.7.7.2. ABSENCE OF ANALYZER RESPONSE TO SAMPLE GAS

If the instrument shows no response (display value is near zero) even though sample gas is supplied properly and the instrument seems to perform correctly:

1. Carry out an optical test using the OPTIC TEST procedure (Run OTest) in the Utilities>Diagnostics>Optics Test menu. See Optic Test (OTest) in Section 5.7.9.11.
 - If this test results in a concentration signal, then the PMT sensor and the electronic signal path are operating properly.
 - If the analyzer passes the OTest, it is capable of detecting light and processing the signal to produce a reading.
 - Therefore, the problem must be in the pneumatics or the ozone generator, in which case, a leak check should be carried out.
2. Check if the ozone generator is turned on.
 - Usually, the analyzer issues a warning whenever the ozone generator is turned off.
 - Go to Utilities>Diagnostics>O3 Gen Override and see if it shows ON.
 - If it shows OFF, turn it ON and check the O₃ Flow reading in the Dashboard menu.
 - If this is done and the ozone flow is correct, the analyzer should be properly supplied with ozone unless the generator itself is broken.
3. Confirm the lack of response by supplying NO or NO₂ span gas of about 80% of the range value to the analyzer.
4. Check the sample flow and ozone flow rates for proper values.
5. Check for disconnected cables to the sensor module.
6. If the NO₂ signal is zero while NO signal is correct, check the NO/NO_x valve and the NO₂ converter for proper operation.
7. If the NH₃ signal is zero while other gas signals are correct, check the TN/TN_x valve and the external converter for proper operation.

5.7.7.3. UNSTABLE ZERO AND SPAN

Leaks in the external gas supply and vacuum systems are the most common source of unstable and non-repeatable concentration readings.

1. Check for leaks in the pneumatic systems as described in Section 5.6.10.
2. Consider pneumatic components in the gas delivery system outside the analyzer such as a change in zero air source (ambient air leaking into zero air line or a worn-out zero air scrubber) or a change in the span gas concentration due to zero air or ambient air leaking into the span gas line.
3. Once the instrument passes a leak check, do a flow check (this chapter) to ensure that the instrument is supplied with adequate sample and ozone air.
4. Confirm the sample pressure, sample temperature, and sample flow readings are correct and steady.
5. Verify that the sample filter element is clean and does not need to be replaced.

5.7.7.4. INABILITY TO SPAN - DEACTIVATED SPAN BUTTON

In general, the analyzer will deactivate certain buttons whenever the actual value of a parameter is outside of the expected range for that parameter. If the Span is grayed out, the actual concentration must be outside of the range of the expected span gas concentration, which can have several causes.

1. Verify that the expected concentration is set properly to the actual span gas concentration in the CONC sub-menu.
2. Confirm that the NO_x span gas source is accurate.
 - This can be done by comparing the source with another calibrated analyzer, or by having the NO_x source verified by an independent traceable photometer.
3. Check for leaks in the pneumatic systems as described in Section 5.6.10.
 - Leaks can dilute the span gas and, hence, the concentration that the analyzer measures may fall short of the expected concentration defined in the CONC sub-menu.
4. If the low-level, hardware calibration has drifted (changed PMT response) or was accidentally altered by the user, a low-level calibration may be necessary to get the analyzer back into its proper range of expected values.
 - One possible indicator of this scenario is a slope or offset value that is outside of its allowed range (0.7-1.3 for slope, -20 to 150 for offsets). See Section 5.7.10.4 on how to carry out a low-level hardware calibration.

5.7.7.5. INABILITY TO ZERO - DEACTIVATED ZERO BUTTON

In general, the analyzer will deactivate certain buttons whenever the actual value of a parameter is outside of the expected range for that parameter. If the Zero button is grayed out, the actual gas concentration must be significantly different from the actual zero point (as per last calibration), which may be for any of several reasons.

1. Confirm that there is a good source of zero air. Check any zero air scrubber for performance. It may need to be replaced (Section 5.6.5.2).
2. Check to ensure that there is no ambient air leaking into zero air line. Check for leaks in the pneumatic systems as described in Section 5.6.10.

5.7.7.6. NON-LINEAR RESPONSE

The analyzer was factory calibrated to a high level of NO and should be linear to within 1% of full scale. Common causes for non-linearity are:

- Leaks in the pneumatic system:
 - Leaks can add ambient air, zero air or span gas to the current sample gas stream, which may be changing in concentrations as the linearity test is performed.
 - Check for leaks as described in Section 5.6.10.
- The calibration device is in error:
 - Check flow rates and concentrations, particularly when using low concentrations.
 - If a mass flow calibrator is used and the flow is less than 10% of the full scale flow on either flow controller, you may need to purchase lower concentration standards.
- The standard gases may be mislabeled as to type or concentration.

- Labeled concentrations may be outside the certified tolerance.
- The sample delivery system may be contaminated.
 - Check for dirt in the sample lines or reaction cell.
 - Calibration gas source may be contaminated (NO₂ in NO gas is common).
 - Dilution air contains sample or span gas.
- Ozone concentration too low because of wet air in the generator.
 - Generator system needs to be cleaned and dried with dry supply air.
 - Check the dryer for leaks.
 - This mostly affects linearity at the low end.
- Ozone stream may be contaminated with impurities.
 - An exhausted ozone cleanser chemical will let compounds such as HNO₃ and ammonia derivatives break through to the reaction cell.
 - Check the contents of the ozone cleanser and replace as necessary (Section 5.6.4).
 - This also will affect linearity mostly at the low level.
- Sample inlet may be contaminated with gas exhaust from this or other analyzers.
 - Verify proper venting of the pump exhaust.
 - Span gas overflow is not properly vented and creates a back-pressure on the sample inlet port.
 - Also, if the span gas is not vented at all and does not supply enough sample gas, the analyzer may be evacuating the sample line.
 - Ensure to create and properly vent excess span gas.
- Diffusion of oxygen into Teflon-type tubing over long distances.
 - PTFE or related materials can act as permeation devices.
 - When using very long supply lines (> 1 m) between high concentration span gases and the dilution system, oxygen from ambient air can diffuse into the line and react with the gas to form another gas.
 - This reaction is dependent on gas concentration and accelerates with increasing gas concentration, hence, affects linearity only at high levels.
 - Using stainless steel for long span gas supply lines avoids this problem.

5.7.7.7. DISCREPANCY BETWEEN ANALOG OUTPUT AND DISPLAY

If the concentration reported through the analog outputs does not agree with the value reported on the front panel, you may need to recalibrate the analog outputs.

- This becomes more likely when using a low concentration or low analog output range.
- Analog outputs running at 0.1 V full scale should always be calibrated manually.
- See Section 2.5.8.1 for a detailed description of this procedure.

5.7.7.8. DISCREPANCY BETWEEN NO AND NO_x SLOPES

If the slopes for NO and NO_x are significantly different after software calibration (more than 1%), consider the following three problems:

- NO₂ impurities in the NO calibration gas. NO gases often exhibit NO₂ on the order of 1-2% of the NO value.
 - This will cause differences in the calibration slopes. If the NO₂ impurity in NO is known, it can easily be accounted for by setting the expected values for NO and NO₂ accordingly to different values, e.g., 448 ppb NO and 450 ppb NO_x.
 - This problem is worse if NO gas is stored in a cylinder with balance air instead of balance gas nitrogen or large amounts of nitrous oxide (N₂O), because the oxygen in the air slowly reacts with NO to yield NO₂, increasing over time.
- The expected concentrations for NO and NO_x in the calibration menu are set to different values.
 - If a gas with 100% pure NO is used, this would cause a bias.
 - See Section 4.2 on how to set expected concentration values.

5.7.8. OTHER PERFORMANCE PROBLEMS

Dynamic problems (i.e., problems that only manifest themselves when the analyzer is monitoring sample gas) can be the most difficult and time consuming to isolate and resolve. The following Section provides an itemized list of the most common dynamic problems with recommended troubleshooting checks and corrective actions.

5.7.8.1. EXCESSIVE NOISE

Excessive noise levels under normal operation usually indicate leaks in the sample supply or the analyzer itself.

- Ensure that the sample or span gas supply is leak-free and carry out a detailed leak check as described earlier in this chapter.

Another possibility of excessive signal noise may be the preamplifier board, the high voltage power supply and/or the PMT detector itself.

- Contact the factory on troubleshooting these components.

5.7.8.2. SLOW RESPONSE

If the analyzer starts responding too slow to any changes in sample, zero or span gas, check for the following:

- Dirty or plugged sample filter or sample lines.
- Sample inlet line is too long.
- Leaking TN_x/NO_x or NO/NO_x valve. Carry out a leak check.
- Dirty or plugged critical flow orifices. Check flows, pressures and, if necessary, change orifices (Section 5.6.8).
- Wrong materials in contact with sample – use materials as laid out in Section 2.3.2.1.
- Dirty reaction cell. Clean the reaction cell.

- Insufficient time allowed for purging of lines upstream of the analyzer. Wait until stability is low.
- Insufficient time allowed for NO or NO₂ calibration gas source to become stable. Wait until stability is low.
- Moly temperature is too low. Check for proper temperature.

5.7.8.3. AUTO ZERO WARNINGS

Auto Zero warnings occur if the signal measured during an Auto Zero cycle is higher than 200 mV.

Note The Auto-Zero warning displays the value of the Auto Zero reading when the warning occurs.

- If this value is higher than 150 mV, check that the Auto Zero valve is operating properly.
 - To do so, use the Utilities>Diagnostics>Digital Outputs menu to toggle the valve on and off.
 - Listen if the valve is switching, see if the respective LED on the relay board is indicating functionality.
- Alternatively, navigate to the Dashboard and observe the PMT value change between the two valve states.
 - If the valve is operating properly, you should be able to hear it switch (once a minute under normal operation or when manually activated from the Utilities>Diagnostics>Digital Outputs menu):
 - the PMT value should drop from span gas reading (e.g., 800-900 mV at 400 ppb NO) to less than 150 mV, and
 - the LED on the relay board should light up when the valve is activated.
 - If the PMT value drops significantly but not to less than 150 mV, the valve is probably leaking across its ports.
 - In this case, replace the valve.
 - If the PMT value does not change at all, the valve is probably not switching at all.
 - Check the power supply to the valve (12 V to the valve should turn on and off when measured with a voltmeter).

Note It takes only a small leak across the ports of the valve to show excessive Auto Zero values when supplying high concentrations of span gas.

Another reason for high (although not necessarily out-of-range) values for Auto Zero could be the ozone air filter cartridge, if its contents have been exhausted and must be replaced.

- This filter cartridge chemicals that can cause chemiluminescence and, if saturated, these chemicals can break through to the reaction cell, causing an erroneously high Auto Zero value (background noise).

A dirty reaction cell can cause high Auto Zero values.

- Clean the reaction cell according to Section 5.6.7.

Finally, a high HVPS voltage value may cause excess background noise and a high Auto Zero value.

- The HVPS value changes from analyzer to analyzer and could show nominal values between 450 and 800 V.
- Check the low-level hardware calibration of the preamplifier board and, if necessary, recalibrate exactly as described in Section 5.7.10.4 in order to minimize the HVPS.

5.7.9. SUBSYSTEM CHECK FOR TROUBLESHOOTING

The preceding sections of this manual discussed a variety of methods for identifying possible sources of failures or performance problems within the analyzer. In most cases this included a list of possible causes and, in some cases, quick solutions or at least a pointer to the appropriate sections describing them. This Section describes how to determine if a certain component or subsystem is actually the cause of the problem being investigated.

5.7.9.1. AC MAIN POWER

The analyzer's electronic systems will operate with any of the specified power regimes. As long as system is connected to 100-120 VAC or 220-240 VAC at either 50 or 60 Hz it will turn on and after about 30 seconds show a front panel display.

- Internally, the status LEDs located on the Relay PCA, Motherboard and CPU should turn on as soon as the power is supplied.
 - If they do not, check the circuit breaker built into the ON/OFF switch on the instrument's front panel.
- If the configuration plug is set for 115 or 100 VAC and the unit is plugged into a 230 VAC circuit, the circuit breaker built into the ON/OFF Switch on the front panel will trip to the OFF position immediately after power is switched on.



WARNING – ELECTRICAL SHOCK HAZARD

Should the AC power circuit breaker trip, investigate and correct the condition causing this situation before turning the analyzer back on.

5.7.9.2. DC POWER SUPPLY

If the analyzer's AC mains power is working, check the DC output with a voltmeter at the test points described in 5-8 and shown in Figure 5-19. Refer to Table 5-9 for acceptable values.

Check for excessive noise (> 100 mV p-p), using an oscilloscope in AC mode with band limiting turned on.

Table 5-8. DC Power Test Point and Wiring Color Codes

NAME	TEST POINT#	COLOR	DEFINITION
DGND	1	Black	Digital ground
+5V	2	Red	
AGND	3	Green	Analog ground
+15V	4	Blue	
-15V	5	Yellow	
+12R	6	Purple	12 V return (ground) line
+12V	7	Orange	

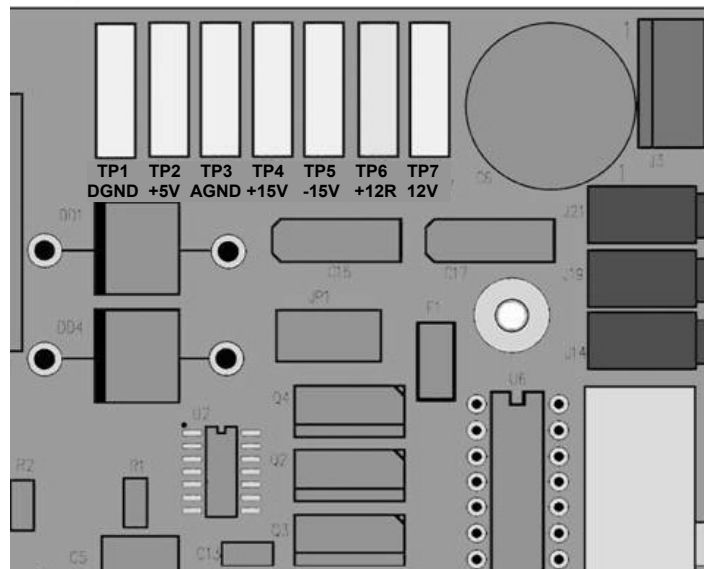

Figure 5-19. Location of DC Power Test Points on Relay PCA

Table 5-9. DC Power Supply Acceptable Levels

POWER SUPPLY	VOLTAGE	CHECK RELAY BOARD TEST POINTS				MIN V	MAX V
		FROM Test Point		TO Test Point			
		NAME	#	NAME	#		
PS1	+5	DGND	1	+5	2	+4.85	+5.25
PS1	+15	AGND	3	+15	4	+13.5	+16.0
PS1	-15	AGND	3	-15V	5	-13.5	-16.0
PS1	AGND	AGND	3	DGND	1	-0.05	+0.05
PS1	Chassis	DGND	1	Chassis	N/A	-0.05	+0.05
PS2	+12	+12V Ret	6	+12V	7	+11.8	+12.5
PS2	DGND	+12V Ret	6	DGND	1	-0.05	+0.05

5.7.9.3. I²C BUS

Verify operation of the I²C bus by checking whether the LEDs are flashing at the Relay PCA's D1 and the Valve Driver PCA's D2. If both are solid lit or are not on, and the DC power supplies are operating properly, there is a problem with the I²C bus.

5.7.9.4. LCD/DISPLAY MODULE

Assuming that there are no wiring problems and that the DC power supplies are operating properly, the display screen should light and show the splash screen and other indications of its state as the CPU goes through its initialization process.

5.7.9.5. RELAY PCA

The Relay PCA can be most easily checked by observing the condition of its status LEDs (see Section 5.7.5.2), and using the Utilities>Diagnostics>Digital Outputs menu (see Section 5.7.3) to toggle each LED ON or OFF.

If D1 on the Relay PCA is flashing and the status indicator for the output in question (Heater power, Valve Drive, etc.) toggles properly using the Signal I/O function, then the associated control device on the Relay PCA is bad.

Several of the control devices are in sockets and can be easily replaced. The following Table lists the control device associated with a particular function:

Table 5-10. Relay PCA Control Devices

FUNCTION	CONTROL DEVICE	SOCKETED
All valves	U5	Yes
Reaction Cell Heater	K1	Yes
NO ₂ -to-NO Heater	K2	Yes

5.7.9.6. MOTHERBOARD

A/D FUNCTIONS

The simplest method to check the operation of the A-to-D converter on the motherboard is to navigate to the Dashboard and check the two A/D reference voltages and input signals that can be easily measured with a voltmeter (configure the Dashboard to show the necessary parameters).

1. Navigate to the Dashboard to view the value of Ref 4096mV and Ref Ground.
 - If both are within 3 mV of nominal (4096 and 0), and are stable (± 0.2 mV) then the basic A/D is functioning properly. If not then the motherboard is bad.
2. Choose a parameter in the Dashboard function list such as O3FLOW.
 - Compare the voltage at its origin (see the interconnect drawing in Appendix B) with the voltage displayed through the signal I/O function.
 - If the wiring is intact but there is a large difference between the measured and displayed voltage (± 10 mV) then the motherboard is bad.

STATUS OUTPUTS

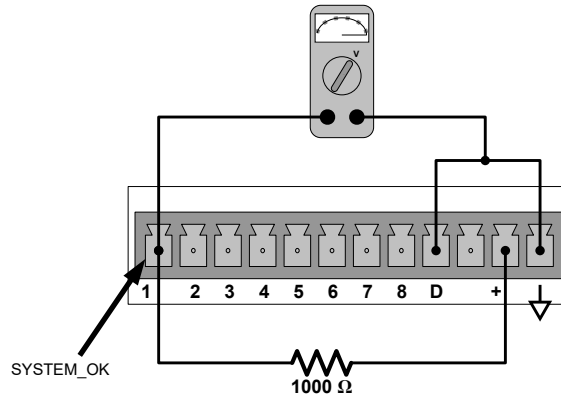

Figure 5-20. Typical Set Up of Status Output Test

To test the status output electronics:

1. Connect a jumper between the “D” pin and the “▽” pin on the status output connector.
2. Connect a 1000 ohm resistor between the “+” pin and the pin for the status output that is being tested.
3. Connect a voltmeter between the “▽” pin and the pin of the output being tested.
4. In the Utilities>Diagnostics>Digital Outputs menu (see Section 5.7.3), scroll through the outputs until you get to the output in question.
5. Alternatively, turn on and off the output noting the voltage on the voltmeter.
 - It should vary between 0 volts for ON and 5 volts for OFF.

CONTROL INPUTS

The control input bits can be tested by applying a trigger voltage to an input and watching changes in the status of the associated function in the Utilities>Diagnostics menu:

EXAMPLE: to test the “A” and “B” control inputs:

1. Under the Utilities>Diagnostics>Digital Inputs menu, scroll through the signals to find EXTERNAL_ZERO_CAL.
2. Connect a jumper from the “+” pin on the appropriate connector to the “U” on the same connector.
3. Connect a second jumper from the “▽” pin on the connector to the “A” pin.
4. The status of EXTERNAL_ZERO_CAL should change to read “ON”.
5. Connect a second jumper from the “▽” pin on the connector to the “B” pin.
6. The status of EXTERNAL_HIGHSPAN_CAL should change to read “ON.”

Table 5-11. Control Input Pin Assignments and Corresponding Signal I/O Functions

INPUT	CORRESPONDING I/O SIGNAL
A	EXT_ZERO_CAL
B	EXT_HIGHSPAN_CAL
C, D, E & F	NOT USED

5.7.9.7. PRESSURE / FLOW SENSOR ASSEMBLY

The flow and pressure sensors are located on a PCA just behind the PMT sensor (see Figure 2-4) can be checked with a voltmeter.

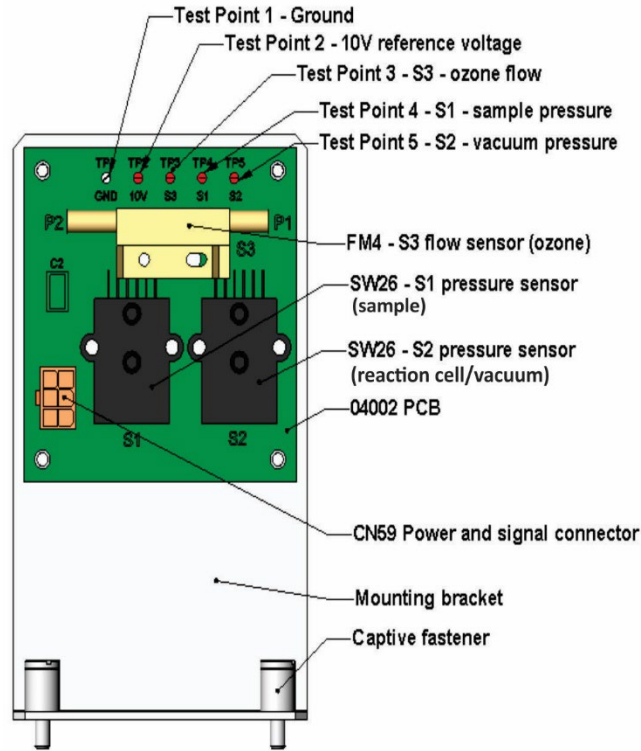

Figure 5-21. Pressure / Flow Sensor Assembly

The following procedure assumes that the wiring is intact and that the motherboard and power supplies are operating properly:

BASIC PCA OPERATION CHECK

- Measure the voltage between TP2 and TP1. It should be 10 VDC \pm 0.25 VDC. If not then the board is bad. Replace the PCA.

SAMPLE PRESSURE SENSOR CHECK

1. Measure the pressure on the inlet side of S1 with an external pressure meter.
2. Measure the voltage across TP4 and TP1.
 - The expected value for this signal should be:

$$\text{Expected mVDC} = \left(\frac{\text{Pressure}}{30.0_{\text{Hg-in-A}}} \times 4660_{\text{mVDC}} \right) + 250_{\text{mVDC}} \quad \pm 10\%_{\text{rdg}}$$

EXAMPLE: If the measured pressure is 20 Hg-in-A, the expected voltage level between TP4 and TP1 would be between 2870 mVDC and 3510 mVDC.

EXAMPLE: If the measured pressure is 25 Hg-in-A, the expected voltage level between TP4 and TP1 would be between 3533 mVDC and 4318 mVDC.

- If this voltage is out of range, then either pressure transducer S1 is bad, the board is bad or there is a pneumatic failure preventing the pressure transducer from sensing the absorption cell pressure properly. Replace the PCA.

VACUUM PRESSURE SENSOR CHECK

1. Measure the pressure on the inlet side of S2 with an external pressure meter.
2. Measure the voltage across TP5 and TP1.
3. Evaluate the reading in the same manner as for the sample pressure sensor.

O₃ FLOW SENSOR CHECK

- Measure the voltage across TP3 and TP1.
 - With proper flow (80 cc³/min through the O₃ generator), this should be approximately 2V ± 0.25 (this voltage will vary with altitude).
 - With flow stopped (Vacuum pump turned Off) the voltage should be approximately 1V.
 - If the voltage is incorrect, the flow sensor S3 is bad, or the board is bad (replace the PCA) or there is a leak upstream of the sensor.

5.7.9.8. CPU

There are two major types of CPU board failures, a complete failure and a failure associated with the Disk on Module (DOM). If either of these failures (described next) occurs, contact the factory.

For a complete failure, assuming that the power supplies are operating properly and the wiring is intact, the CPU is faulty if on power-on, the watchdog LED on the motherboard is not flashing.

- In some rare circumstances, this failure may be caused by a bad IC on the motherboard, specifically U57, the large 44 pin device on the lower right hand side of the board. If this is true, removing U57 from its socket will allow the instrument to start up but the measurements will be invalid.

- For a failure associated with the DOM, the analyzer could stop during initialization (the front panel display shows a fault or warning message), a likely indicator that the DOM, the firmware or the configuration and data files have been corrupted.

5.7.9.9. RS-232 COMMUNICATIONS

GENERAL RS-232 TROUBLESHOOTING

Teledyne API's analyzers use the RS-232 communications protocol to allow the instrument to be connected to a variety of computer-based equipment. Problems with RS-232 connections usually center around five general areas:

- Incorrect cabling and connectors. See Section 2.3.1.8 under RS-232 Connection for connector and pin-out information.
- The BAUD rate and protocol are incorrectly configured. See Section 2.3.1.8 under RS-232 Connection.
- If a modem is being used, additional configuration and wiring rules must be observed. See Sections 3.1 and 3.2.
- Incorrect setting of the DTE – DCE Switch. See Section 3.1 to set correctly.
- Possible improper/incomplete seating of the cable (P/N 03596) that connects the serial COM ports of the CPU to J12 of the motherboard.

TROUBLESHOOTING ANALYZER/MODEM OR TERMINAL OPERATION

These are the general steps for troubleshooting problems with a modem connected to a Teledyne API's analyzer.

1. Check cables for proper connection to the modem, terminal or computer.
2. Check to ensure that the DTE-DCE is in the correct position as described in Section 3.1.
3. Check to ensure that the set up command is correct.
4. Verify that the Ready to Send (RTS) signal is at logic high. The analyzer sets pin 7 (RTS) to greater than 3 volts to enable modem transmission.
5. Ensure that the BAUD rate, word length, and stop bit settings between modem and analyzer match.
6. Use the RS-232 test function to send “w” characters to the modem, terminal or computer.
7. Get your terminal, modem or computer to transmit data to the analyzer (holding down the space bar is one way); the green LED should flicker as the instrument is receiving data.
8. Ensure that the communications software or terminal emulation software is functioning properly.

5.7.9.10. CONVERTERS (NO₂ → NO AND TN_x → NO)

Provided that oxygen was present in the Sample stream during operation for each of the converters (internal to the analyzer and the external 501) to function properly, either converter assembly can fail in two ways:

- An electrical failure of the band heater and/or the thermocouple control circuit and;
- A performance failure of the converter itself.

CONVERTER ELECTRICAL FAILURE

Converter heater failures can be divided into two possible categories:

- Temperature is reported properly but heater does not heat to full temperature.
 - In this case, the heater is either disconnected or broken or the power relay is broken.
 - Disconnect the heater cable coming from the relay board and measure the resistance between any two of the three heater leads with a multi-meter.
 - The resistance between A and B should be about 1000 Ω .
 - The resistance between A and C should be the same as between B and C, about 500 Ω each.
 - If any of these resistances is near zero or without continuity, the heater is broken.
 - Temperature reports zero or overload (near 500° C).
 - This indicates a disconnected or failing thermocouple or a failure of the thermocouple circuit.
 - Check that the thermocouple is connected properly and the wire does not show signs of a broken or kinked pathway.
 - If it appears to be properly connected, disconnect the yellow thermocouple plug (marked K) from the relay board and measure the voltage (not resistance) between the two leads with a multi-meter capable of measuring in the low mV range.
 - The voltage should be about 12 mV (ignore the sign) at 315° C and about 0 mV at room temperature.
 - Measure the continuity with an Ohm-meter.
 - It should read close to zero Ω . If the thermo-couple does not have continuity, it is broken.
 - If it reads zero voltage at elevated temperatures, it is broken.
 - To test the thermocouple at room temperature, heat up the converter can (e.g., with a heat gun) and see if the voltage across the thermocouple leads changes.
 - If the thermocouple is working properly, the electronic circuit is broken.

ATTENTION

COULD DAMAGE INSTRUMENT AND VOID WARRANTY

If the thermocouple is broken, do NOT replace the thermocouple without first consulting the factory; using the wrong Type could cause permanent damage to the instrument. The Type K thermocouple has a red and a yellow wire. If in doubt, consult the factory.

CONVERTER FAILURE

The efficiency at which either converter changes NO₂ or NH₃ to NO directly affects the accuracy of the gas measurements. As previously described in Section 4.1.9, the analyzer's firmware includes a Converter Efficiency (CE) gain factor that is used to calculate the final concentrations for each gas.

To ensure accurate operation, it is important to check the CE periodically. See Section 4.5 for checking and calculating the NO₂ CE and Section 4.2.1.3 for NH₃ CE (noting that the analyzer's CE check procedure should be completed prior to the procedure for the external converter).

- For the converter to function correctly, the CE readings (Conv Eff NH₃ and Conf Eff NO₂) must be greater than 0.9600 (96% conversion efficiency) as per US-EPA requirements.
- If the converter's efficiency is below this limit, the converter should be replaced.
- The current converter efficiency level is also recorded along with the calibration data in the DAS for documentation and performance analysis (Section 2.5.1).

5.7.9.11. PHOTOMULTIPLIER TUBE (PMT) SENSOR MODULE

The PMT detects the light emitted by the reaction of NO with ozone. It has a gain of about 500,000 to 1,000,000. It is not possible to test the detector outside of the instrument in the field. The basic method to diagnose a PMT fault is to eliminate the other components using ETEST, OTEST and specific tests for other sub-assemblies.

OPTIC TEST (OTEST)

The optic test function tests the response of the PMT sensor by turning on an LED located in the cooling block of the PMT (see Figure 5-23). The analyzer uses the light emitted from the LED to test its photo-electronic subsystem, including the PMT and the current to voltage converter on the pre-amplifier board.

- To ensure that the analyzer measures only the light coming from the LED, the analyzer should be supplied with zero air.
- The optic test should produce a PMT signal of about 2000±1000 mV.

To activate the optics test, go to the Utilities>Diagnostics>OE Test menu and press the Run OTest button.

Note

This is a coarse test for functionality and not an accurate calibration tool. The resulting PMT signal can vary significantly over time and also changes with low-level calibration.

ELECTRICAL TEST (ETEST)

The electrical test function creates a current, which is substituted for the PMT signal and feeds it into the preamplifier board.

- This signal is generated by circuitry on the pre-amplifier board itself and tests the filtering and amplification functions of that assembly along with the A/D converter on the motherboard.

- It does not test the PMT itself.
- The electrical test should produce a PMT signal of about 2000 ± 1000 mV.

To activate the electrical test, go to the Utilities>Diagnostics>OETest menu and press the Run ETest button.

5.7.9.12. PMT PREAMPLIFIER BOARD

To check the correct operation of the preamplifier board, perform an optics test (Utilities>Diagnostics>OE Test>Run OTest) and an electrical test (Utilities>Diagnostics>OE Test>Run ETest) described in Section 5.7.9.11 above.

- If the instrument passes the OTEST but fails the ETEST, the preamplifier board may be faulty or need a hardware calibration.

5.7.9.13. HIGH VOLTAGE POWER SUPPLY (HVPS)

The HVPS is located in the interior of the sensor module and is plugged into the PMT tube. It requires two voltage inputs.

- The first is +15 V, which powers the supply.
- The second is the programming voltage which is generated on the preamplifier board.
- Adjustment of the HVPS is covered in the factory calibration procedure in Section 5.7.10.4.

This power supply has 10 independent power supply steps, one to each pin of the PMT. The following test procedure below allows you to test each step.

1. Turn off the instrument.
2. Remove the cover and disconnect the two connectors at the front of the NOx sensor module.
3. Remove the end cap from the sensor (four screws).
4. Remove the HVPS/PMT assembly from the cold block inside the sensor (two plastic screws).
5. Disconnect the PMT from the HVPS.
6. Re-connect the 7-pin connector to the sensor end cap, and power-up the instrument.
7. Navigate to the HVPS parameter in the Dashboard (if not shown, configure the Dashboard to display HVPS, Section 2.5.3).
8. Divide the displayed HVPS voltage by 10 and test the pairs of connector points as shown in the example below.
9. Check the overall voltage (should be equal to the HVPS value displayed in the Dashboard and the voltages between each pair of pins of the supply).

EXAMPLE: if the HVPS signal is 700 V the pin-to-pin voltages should be 70 V.

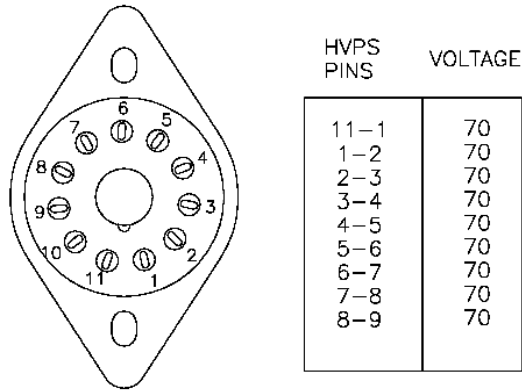

10. Turn off the instrument power, and reconnect the PMT, and then reassemble the sensor.
 - If any faults are found in the test, you must obtain a new HVPS as there are no user serviceable parts inside the supply.

5.7.9.14. PMT TEMPERATURE CONTROL PCA

The temperature control PCA is located on the sensor housing assembly, under the slanted shroud, next to the cooling fins and directly above the cooling fan.

If the red LED located on the top edge of this assembly is not glowing the control circuit is not receiving power. Check the analyzer's power supply, the relay board's power distribution circuitry and the wiring connecting them to the PMT temperature control PCA.

TEC CONTROL TEST POINTS

Four test points are also located at the top of this assembly and they are numbered left to right, starting with the T1 point immediately to the right of the power status LED. These test points provide information regarding the functioning of the control circuit.

- To determine the current running through the control circuit, measure the voltage between T1 and T2. Multiply that voltage by 10.
 - To determine the drive voltage being supplied by the control circuit to the TEC, measure the voltage between T2 and T3.
 - If this voltage is zero, the TEC circuitry is most likely open.
- or,
- If the voltage between T2 and T3 = 0 VDC and the voltage measured between T1 and T2 is 0 VDC, there is most likely an open circuit or failed op amp on control PCA itself.
 - If the voltage between T2 and T3 is 0 VDC and the voltage measured between T1 to T2 is some voltage other than 0 VDC, the TEC is most likely shorted.
 - T4 is tied directly to ground. To determine the absolute voltage on any one of the other test points make a measurement between that test point and T4.

5.7.9.15. O₃ GENERATOR

The ozone generator can fail in two ways, electronically (printed circuit board) and functionally (internal generator components). Assuming that air is supplied properly to the generator, the generator should automatically turn on 30 minutes after the instrument is

powered up or if the instrument is still warm. See Section 6.2.3 for ozone generator functionality. Accurate performance of the generator can only be determined with an ozone analyzer connected to the outlet of the generator. However, if the generator appears to be working properly but the sensitivity or calibration of the instrument is reduced, suspect a leak in the ozone generator supply air.

A leak in the dryer or between the dryer and the generator can reduce sensitivity and cause performance drift. Carry out a leak check (Section 5.6.10).

O₃ GENERATOR OVERRIDE

This feature in the Utilities>Diagnostics menu is used to manually turn the ozone generator off and on. This should be done before disconnecting the generator, to prevent ozone from leaking out, or after a system restart if the user does not want to wait for 30 minutes during warm-up time.

Note

The ozone generator does not turn on if the ozone flow conditions are out of specification, e.g., if there is no flow through the system or the pump is broken.

5.7.9.16. TEMPERATURE SENSOR

BOX TEMPERATURE SENSOR

The box temperature sensor (thermistor) is mounted on the motherboard below the bottom edge of the CPU board when looking at it from the front. It cannot be disconnected to check its resistance.

- Box temperature will vary with, but will usually read about 5° C higher than, ambient (room) temperature because of the internal heating zones from the NO₂ converter, reaction cell and other devices.
- To check the box temperature functionality, we recommend checking the Box Temp signal voltage in the Utilities>Diagnostics>Analog Inputs menu (Section 5.7.3).
- At about 30° C, the signal should be around 1500 mV.
- To check the accuracy of the sensor, use a calibrated external thermometer / temperature sensor to verify the accuracy of the box temperature by:
- Placing it inside the chassis, next to the thermistor labeled XT1 (above connector J108) on the motherboard.
- Compare its reading to the value of the PMT TEMP.

PMT TEMPERATURE SENSOR CONTROL

The temperature of the PMT should be low and constant. It is more important that this temperature is maintained at a constant level than it is to be a specific temperature.

The PMT cooler uses a Peltier, thermo-electric cooler element supplied with 12 V DC power from the switching power supply PS2. The temperature is controlled by a proportional temperature controller located on the preamplifier board.

- Voltages applied to the cooler element vary from 0.1 to 12 VDC.
- The temperature set point (hard-wired into the preamplifier board) will vary by ± 2 ° C.
- The actual temperature will be maintained to within 0.1° C around that set point.

To check the operation of the PMT temperature control system:

1. Turn off the analyzer and let its internal components cool / heat to ambient temperature.
2. Turn on the analyzer.
3. Set the front panel to show the PMT TEMP test function (Setup>Dashboard).
 - The temperature should fall steadily to 6-10° C.
 - If the temperature fails to reach this point after 60 minutes, there is a problem in the cooler circuit.
 - If the control circuit on the preamplifier board is faulty, a temperature of -1° C will be reported.

5.7.10. SERVICE PROCEDURES

This Section contains some procedures that may need to be performed when a major component of the analyzer requires repair or replacement.

Note

Regular maintenance procedures are discussed in Section 5.5 and are not listed here). Also, there may be more detailed service notes for some of the below procedures. Contact Teledyne API's Technical Support Department.



WARNING – ELECTRICAL SHOCK HAZARD

Unless the procedure being performed requires the instrument to be operating, turn it off and disconnect power before opening the analyzer and removing, adjusting or repairing any of its components or subsystems.



CAUTION – QUALIFIED TECHNICIAN

The operations outlined in this chapter are to be performed by qualified maintenance personnel only.

5.7.10.1. DISK-ON-MODULE REPLACEMENT PROCEDURE

ATTENTION

COULD DAMAGE INSTRUMENT AND VOID WARRANTY

Servicing of circuit components requires electrostatic discharge protection, i.e. ESD grounding straps, mats and containers. Failure to use ESD protection when working with electronic assemblies will void the instrument warranty. For information on preventing ESD damage, refer to the manual, Fundamentals of ESD, PN 04786, which can be downloaded from our website at <http://www.teledyne-api.com> under Help Center > Product Manuals in the Special Manuals section.

Replacing the Disk-on-Module (DOM) will cause loss of all DAS data; it may also cause loss of some instrument configuration parameters unless the replacement DOM carries the exact same firmware version. Whenever changing the version of installed software, the

memory must be reset. Failure to ensure that memory is reset can cause the analyzer to malfunction, and invalidate measurements. After the memory is reset, the A/D converter must be re-calibrated, and all information collected in Step 1 below must be re-entered before the instrument will function correctly. Also, zero and span calibration should be performed.

1. Document all analyzer parameters that may have been changed, such as range, auto-cal, analog output, serial port and other settings before replacing the DOM.
2. Turn off power to the instrument, fold down the rear panel by loosening the mounting screws.
3. While looking at the electronic circuits from the back of the analyzer, locate the Disk-on-Module in the right-most socket of the CPU board.
4. The DOM should carry a label with firmware revision, date and initials of the programmer.
5. Remove the nylon standoff clip that mounts the DOM over the CPU board, and lift the DOM off the CPU. Do not bend the connector pins.
6. Install the new Disk-on-Module, making sure the notch at the end of the chip matches the notch in the socket.
7. It may be necessary to straighten the pins somewhat to fit them into the socket. Press the chip all the way in.
8. Close the rear panel and turn on power to the machine.
9. If the replacement DOM carries a firmware revision, re-enter all of the setup information.

5.7.10.2. O₃ GENERATOR REPLACEMENT

The ozone generator is a black, brick-shaped device with a printed circuit board attached to its rear and two tubes extending out the right side in the front of the analyzer (see Figure 2-4). The board has a red LED that, when lit, indicates ozone is being generated. To replace the ozone generator:

1. Turn off the analyzer power; remove the power cord and the analyzer cover.
2. Disconnect the 1/8" black tube from the ozone cleanser and the 1/4" clear tube from the plastic extension tube at the brass fitting nearest to the ozone generator.
3. Unplug the electrical connection on the rear side of the brick.
4. Unscrew the two mounting screws that attach the ozone generator to the chassis and take out the entire assembly.
5. If you received a complete replacement generator with circuit board and mounting bracket attached, simply reverse the above steps to replace the current generator.

Note

Ensure to carry out a leak check (Section 5.6.10) and a recalibration after the analyzer has warmed up for about 60 minutes.

5.7.10.3. SAMPLE AND OZONE DRYER REPLACEMENT

The analyzer's standard configuration is equipped with a dryer for the ozone supply air. An optional dryer is available for the sample stream, and a combined dryer for both gas streams can also be purchased. To change one or both of these dryers:

1. Turn off power to the analyzer and pump, and remove the power cord and the analyzer cover.
2. Locate the dryer(s), and *gently* disconnect all tubing that extends out of the dryer assembly.

Note

Do not twist any of the white plastic fittings on the dryer: they connect the inner drying tube to the outer purge tube and are delicate. See Section 5.6.1.

3. Make note of the dryer's orientation on the bracket in order to correctly position the replacement dryer.
4. Cut the tie wraps that hold the dryer to the mounting bracket and take out the old dryer.
 - If necessary, unscrew the two mounting screws on the bracket and take out the entire assembly.
5. Attach the replacement dryer to the mounting bracket in the same orientation as the old dryer.
6. Fix the dryer to the bracket using new tie wraps.
7. Cut off excess length of the wraps.
8. Put the assembly back into the chassis and tighten the mounting screws.
9. Use at least two wrenches to carefully re-attach the tubes to vacuum manifold, flow meter and/or NO/NOx valve using at least two wrenches.

Note

Avoid twisting the dryer's white plastic fittings, as this will result in large leaks, which are difficult to trouble-shoot or fix.

10. Carry out a detailed leak check (see Section 5.6.10.2),
11. Close the analyzer and reconnect the power cord.
12. Power up pump and analyzer and re-calibrate the instrument after it stabilizes.

5.7.10.4. PMT SENSOR HARDWARE CALIBRATION

The sensor module hardware calibration is used in the factory to adjust the slope and offset of the PMT output and to optimize the signal output and HVPS.

- If the instrument's slope and offset values are outside the acceptable range and all other more obvious causes for this problem have been eliminated, the hardware calibration can be used to adjust the sensor as was done in the factory.

- This procedure is also recommended after replacing the PMT or the preamplifier board.

To calibrate the PMT preamplifier PCA:

1. Perform a full zero point calibration using zero air (see Section 4.2.1.1).
2. Display the NOX Stability value either on the NOX plot by clicking the NOX label or value in the display, or if configured in a Home page meter (Section 2.5.6) or in the Dashboard (Section 2.5.3).
3. Locate the preamplifier board (PMT Preamp PCA) (see Figure 2-4).
4. Locate the following components on the preamplifier board (Figure 5-22):
 - HVPS coarse adjustment switch (Range 0-9, then A-F).
 - HVPS fine adjustment switch (Range 0-9, then A-F).
 - Gain adjustment potentiometer (Full scale is 10 turns).
5. Turn the gain adjustment potentiometer 12 turns clockwise or to its maximum setting.
6. Feed NO gas into the analyzer.
 - This should be 90% of the upper limit setting for the T201's reporting range:

EXAMPLE: if the reporting range is set at 500 ppb, use 450 ppb NO.

7. Wait until the Stability is below 0.5 ppb

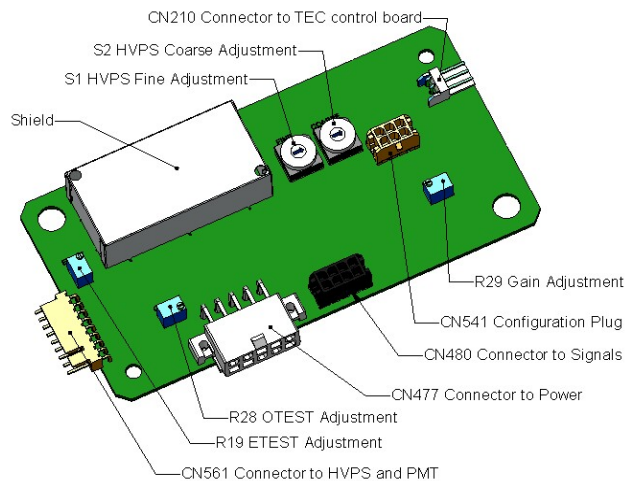

Figure 5-22. Pre-Amplifier Board Layout

8. Scroll to the Normalized PMT function in the analyzer's Dashboard.
9. With the NO gas concentrations mentioned in Step 5 above, the Normalized PMT value should be 900 mV.
10. Set the HVPS coarse adjustment to its minimum setting (0).
11. Set the HVPS fine adjustment switch to its maximum setting (F).
 - Set the HVPS coarse adjustment switch to the lowest setting that will give you just above the target value for Normalized PMT signal.
12. Adjust the HVPS fine adjustment such that the Normalized PMT value is close to the target value.

- It may be necessary to go back and forth between coarse and fine adjustments if the proper value is at the threshold of the min/max coarse setting.

ATTENTION

COULD DAMAGE INSTRUMENT AND VOID WARRANTY

Do not overload the PMT by accidentally setting both adjustment switches to their maximum setting. Start at the lowest setting and increment slowly: no sooner than every 10 seconds between adjustments.

Note

During these adjustments, the Normalized PMT value will fluctuate as the analyzer continues to switch between streams as well as between measure and Auto Zero modes.

13. Perform a span point calibration (Section 4.2.1.2) to normalize the sensor response to its new PMT sensitivity.
14. Review the slope and offset values:
 - The slope values should be 1.000 ± 0.300 .
 - The offset values should be approximately 0.0 (-20 to +150 mV is allowed).

5.7.10.5. PMT, HVPS OR TEC REPLACEMENT

The photo multiplier tube (PMT) should last for the lifetime of the analyzer, however, the high voltage power supply (HVPS) or the thermo-electric cooler (TEC) components may fail. Replacing any of these components requires opening the sensor module. This is a delicate assembly and it is recommend that you ensure the PMT, HVPS or TEC modules are, indeed, faulty before unnecessarily opening of the module.

CAUTION – QUALIFIED PERSONNEL



While the PMT or HVPS can be removed through the front panel without un-mounting the entire sensor module, we recommend turning off the instrument, opening its top cover and removing the entire assembly so that further repairs can be carried out at an anti-ESD workstation.

Follow the guidelines for preventing electrostatic damage to electronic components, defined in the manual, Fundamentals of ESD, PN 04786, which can be downloaded from our website at <http://www.teledyne-api.com> under Help Center > Product Manuals in the Special Manuals section..

1. Turn OFF the analyzer and disconnect the power cord.
2. Remove the cover.
3. Disconnect all pneumatic and electrical connections from the sensor assembly.
4. Remove the sensor assembly.

5. If the TEC is to be replaced, remove the reaction cell assembly at this point by unscrewing two holding screws.
 - This is necessary only if the repair being performed involves removing the PMT cold block.

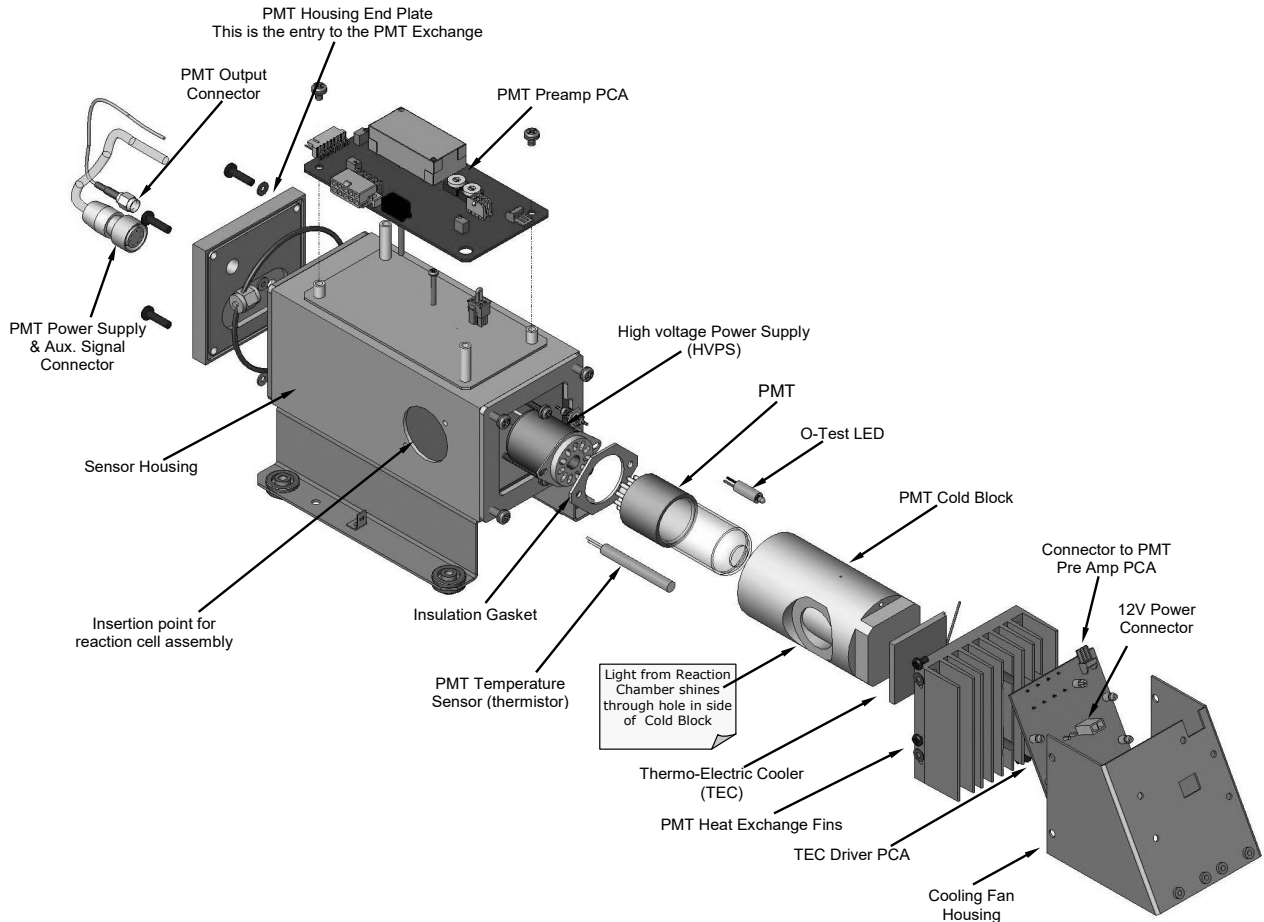

Figure 5-23. Sensor Assembly

6. Remove the two connectors on the PMT housing end plate facing towards the front panel.
7. Remove the end plate itself (4 screws with plastic washers).

Note

Any time the black PMT housing end plate for the Sensor Assembly is removed, replace the five desiccant bags inside the housing.

8. Remove the desiccant bags from the PMT housing.
9. Unscrew the PMT assembly, which is held to the cold block by two plastic screws.
10. Discard the plastic screws and replace with new screws at the end of this procedure (the threads get stripped easily and it is recommended to use new screws).
11. Along with the plate, slide out the optic test (O-Test) LED and the thermistor that measures the PMT temperature.

- Thermistor will be coated with a white, thermal conducting paste.
 - Do not contaminate the inside of the housing with this grease, as it may contaminate the PMT glass tube on re-assembly.
12. Carefully take out the assembly consisting of the HVPS, the insulation gasket and the PMT.
 13. Change the PMT or the HVPS or both, clean the PMT glass tube with a clean, anti-static wipe and do not touch it after cleaning.
 14. If the cold block or TEC is to be changed:
 - Disconnect the TEC driver board from the preamplifier board, remove the cooler fan duct (4 screws on its side) including the driver board.
 - Disconnect the driver board from the TEC and set the sub-assembly aside.
 15. Remove the end plate with the cooling fins (4 screws) and slide out the PMT cold block assembly, which contains the TEC.
 16. Unscrew the TEC from the cooling fins and the cold block and replace it with a new unit.
 17. Reassemble this TEC subassembly in reverse order.
 - Ensure to use thermal grease between TEC and cooling fins as well as between TEC and cold block and that the side opening in the cold block will face the reaction cell when assembled.
 - Evenly tighten the long mounting screws for good thermal conductivity.

CAUTION – QUALIFIED PERSONNEL



The thermo-electric cooler needs to be mounted flat to the heat sink.

If there is any significant gap, the TEC might burn out. Ensure to apply heat sink paste before mounting it and tighten the screws evenly and cross-wise.

18. Reinsert the TEC subassembly in reverse order.
 - Ensure that the O-ring is seated properly and the assembly is tightened evenly.
19. Insert the O-Test LED and thermistor into the cold block, insert new desiccant bags and carefully replace the end plate by making sure that the O-ring is properly in place.
 - Improperly placed O-rings will cause leaks, which – in turn – cause moisture to condense on the inside of the cooler and likely cause a short in the HVPS.
20. Reinsert the PMT/HVPS subassembly in reverse order.
 - Don't forget the insulation gasket between HVPS and PMT.
 - Use new plastic screws to mount the PMT assembly on the PMT cold block.
21. Install new silica gel packets (desiccant bags).
22. Reconnect the cables and the reaction cell (evenly tighten these screws).
23. Replace the sensor assembly into the chassis and fasten with four screws and washers.
24. Reconnect all electrical and pneumatic connections.

25. Leak check the system (see Section 5.6.10).
26. Turn ON the analyzer.
27. Verify the basic operation of the analyzer using the ETEST and OTEST features (Section 5.7.9.11) or zero and span gases, then carry out a hardware calibration of the analyzer followed by a zero/span point calibration Section 4.2.1).

5.7.10.6. REMOVING / REPLACING THE RELAY PCA FROM THE INSTRUMENT

This is the most commonly used version of the Relay PCA. It includes a bank of solid state AC relays. This version is installed in analyzers where components such as AC powered heaters must be turned ON & OFF.

A retainer plate is installed over the relay to keep them securely seated in their sockets.

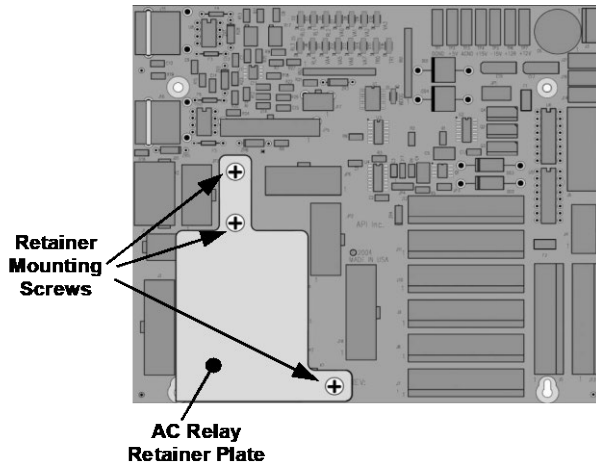

Figure 5-24. Relay PCA with AC Relay Retainer In Place

The Relay retainer plate installed on the relay PCA covers the lower right mounting screw of the relay PCA. Therefore, when removing the relay PCA, the retainer plate must be removed first.

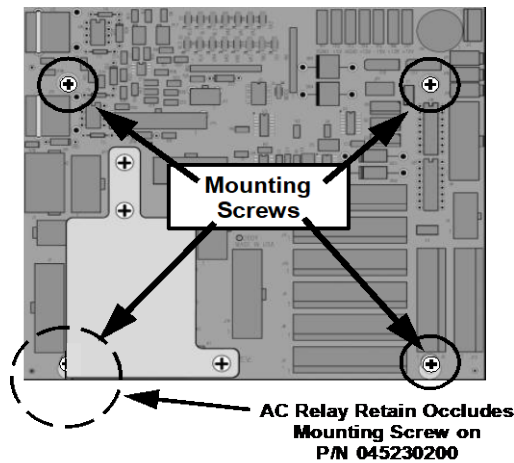

Figure 5-25. Relay PCA Mounting Screw Locations

5.8. FREQUENTLY ASKED QUESTIONS

The following list was compiled from the Teledyne API's Technical Support Department's ten most commonly asked questions relating to the analyzer.

QUESTION	ANSWER
Why does the ENTR button sometimes disappear on the front panel display?	Sometimes the ENTR button will disappear if you select a setting that is invalid or out of the allowable range for that parameter, such as trying to set the 24-hour clock to 25:00:00 or a range to less than 1 or more than 20000 ppb. Once you adjust the setting to an allowable value, the ENTR button will re-appear.
Why is the ZERO or SPAN button deactivated during calibration?	This happens when the measured gas concentration differs significantly from the span or zero gas concentration value entered by the user. This prevents accidental recalibration of the analyzer to an out-of-range response curve. EXAMPLE: The span set point is 400 ppb but gas concentration being measured is only 50 ppb.
How do I enter or change the value of my Span Gas?	See Section 4.2.1.2.
Can I automate the calibration of my analyzer?	Any analyzer with the zero/span valve option can be automatically calibrated using the instrument's AutoCal feature (Section 4.3).
Can I use the Zero/Span option to calibrate the analyzer?	Yes.
How do I measure the sample flow?	For accurate measurement, attach a calibrated flow meter to the sample inlet port, and get a reading while the instrument is operating. The sample flow should be as specified in Table 1-1. (To calibrate, use the Utilities>Diagnostics menu; refer to Section 5.6.10.3).
How often do I need to change the particulate filter?	Refer to the Maintenance Schedule in Table 5-1. Keep in mind that highly polluted sample air may require more frequent changes.
How long does the sample pump last?	The sample pump should last one to two years and the pump head should be replaced when necessary. If the reaction cell pressure value goes above 10 in-Hg-A, on average, the pump head needs to be rebuilt.
Why does my RS-232 serial connection not work?	There are several possible reasons: <ul style="list-style-type: none"> • The wrong cable: please use the provided or a generic "straight-through" cable (do not use a "null-modem" type cable) and ensure the pin assignments are correct (Section 2.3.1.8 under RS-232 Connection). • The DCE/DTE switch on the back of the analyzer is not set properly; ensure that both green and red lights are on (Section 3.1). • The baud rate of the analyzer's COM port does not match that of the serial port of your computer/data logger (Table 2-13).
How do I make the instrument's display and my data logger agree?	This most commonly occurs when an independent metering device is used besides the data logger/recorder to determine gas concentration levels while calibrating the analyzer. These disagreements result from the analyzer, the metering device and the data logger having slightly different ground levels. Use the data logger itself as the metering device during calibration procedures.

QUESTION	ANSWER
Do the critical flow orifices of my analyzer require regular replacement?	No. The o-rings and the sintered filter associated with them require replacement once a year, but the critical flow orifices do not. See Section 5.6.8 for instructions.
How do I set up and use the contact closures (Control Inputs) on the rear panel of the analyzer?	See Section 2.3.1.5.

5.9. TECHNICAL ASSISTANCE

If this manual and its troubleshooting & service section do not solve your problems, technical assistance may be obtained from:

Teledyne API Technical Support
9970 Carroll Canyon Road
San Diego, California 92131-1106 USA

Toll-free Phone: +1 800-324-5190

Phone: +1 858-657-9800

Fax: +1 858-657-9816

Email: api-techsupport@teledyne.com

Website: <http://www.teledyne-api.com/>

6. PRINCIPLES OF OPERATION

The Teledyne-API Model T201 analyzer measures ammonia (NH₃) by oxidizing it to nitric oxide (NO) by the following reaction:

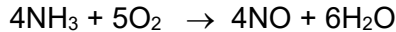

The resulting nitric oxide is then measured by the chemiluminescent reaction with ozone (see Section 6.1 for nitric oxide measurement details).

The analyzer uses two converters to oxidize the different sample gases. The 501 NH₃ is an external high temperature catalytic converter that converts NH₃ and NO_x into NO creating the TN_x channel. A second converter, housed inside the T201 analyzer and consisting of heated molybdenum, converts all of the NO_x in the sample to NO producing the NO_x channel. The nitric oxide channel is measured while bypassing both the 501 NH₃ and molybdenum converter. A sample dryer operated in reflux mode, is installed prior to the molybdenum converter and the AutoZero valve. The dryer removes ammonia and water from the switched stream. The ammonia would have otherwise been converted by the molybdenum and registered as NO_x. This location provides the dryer with continuous flow, thereby allowing it to stabilize faster.

Note Due to the sample dryer, the analyzer has a maximum ammonia range of 2.0 PPM.

The calculated gas concentrations, ammonia and nitrogen dioxide, are computed from the differences between the measured channels, as outlined in the following equations:

NO (Nitric Oxide) Concentration = Measured

TN_x (Total Nitrogen) Concentration = Measured (NH₃ + NO₂ + NO)

NO_x (Total Nitrogen – Ammonia) Concentration = Measured (NO₂ + NO)

NH₃ (Ammonia) Concentration = Calculated as follows:

$$[(\text{TN}_x - \text{NO}_x) / (\text{NH}_3_CE_FACTOR1)]$$

NO₂ (Nitrogen Dioxide) Concentration = Calculated as follows:

$$[(\text{NO}_x - \text{NO}) / (\text{NO}_2_CE_FACTOR1)]$$

6.1. MEASUREMENT PRINCIPLES

To determine the concentration of nitric oxide (NO), total nitrogen oxides (NO_x, the sum of NO and NO₂) and nitrogen dioxide (NO₂), a sample gas is drawn through the analyzer's reaction cell where the sample gas is exposed to ozone (O₃), initiating a chemical reaction that gives off light (hv), known as chemiluminescence. The instrument measures the amount of chemiluminescence to determine the amount of NO in the sample gas (details are presented in Sections 6.1.1 and 6.1.2). A catalytic-reactive converter converts NO₂ in the sample gas to NO which, along with the NO present in the sample, is reported as NO_x. NO₂ is calculated as the difference between NO_x and NO.

This same principle applies in the 501, where the external converter converts the NH₃ and the NO₂ into NO, with the sample gas being exposed to ozone to get the TN_x measurement.

Calibration of the instrument is performed in software and usually does not require physical adjustments to the instrument. During calibration, the microprocessor measures the sensor output signal when gases with known amounts of NO or NO₂ are supplied and stores these results in memory. The microprocessor uses these calibration values along with the signal from the sample gas and data of the current temperature and pressure of the gas to calculate a final NO_x / TN_x concentrations.

The concentration values and the original information from which it was calculated are stored in the unit's internal data acquisition system and are reported to the user through the front panel display, the output ports, and through the Data Logger feature through the Setup menu.

6.1.1. CHEMILUMINESCENCE CREATION IN THE REACTION CELL

The analyzer measures the amount of NO present in a gas by detecting the chemiluminescence which occurs when nitrogen oxide (NO) is exposed to ozone (O₃). This reaction is a two-step process:

- In the first step, one molecule of NO and one molecule of O₃ collide and chemically react to produce one molecule of oxygen (O₂) and one molecule of nitrogen dioxide (NO₂). Some of the NO₂ molecules created by this reaction retain excess energy from the collision and exist in an excited state, where one of the electrons of the NO₂ molecule resides in a higher energy state than normal (denoted by an asterisk in the following equation).

Equation 6-1

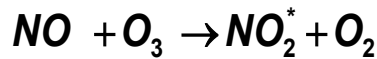

- The second step occurs because the laws of thermodynamics require that systems seek the lowest stable energy state available, therefore the excited NO₂ molecule quickly returns to its ground state, releasing the excess energy. This release takes the form of a quantum of light ($h\nu$). The distribution of wavelengths for these quanta range between 600 and 3000 nm, with a peak at about 1200 nm.

Equation 6-2

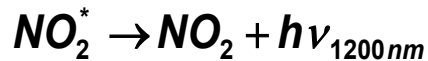

- All things being constant (temperature, pressure, amount of ozone present, etc.), the relationship between the amount of NO present in the reaction cell and the amount of light emitted from the reaction is very linear. If more NO is present, more IR light is produced. By measuring the amount of IR light produced with a sensor sensitive in the near-infrared spectrum (see Figure 6-2) the amount of NO present can be determined.

In addition, sometimes the excited NO₂ collides with other gaseous molecules in the reaction cell chamber or even the molecules of the reaction cell walls and transfers its excess energy to this collision partner (represented by M in Equation 6-3 below) without emitting any light at all. In fact, by far the largest portion of the excited NO₂ returns to the ground state this way, leaving only a few percent yield of usable chemiluminescence.

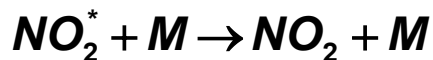

The probability of a collision between the NO_2^* molecule and a collision partner M increases proportionally with the reaction cell pressure. This non-radiating collision with the NO_2^* molecules is usually referred to as *third body quenching*, an unwanted process further described in Section 6.1.6.2.

Even under the best conditions only about 20% of the NO_2 that is formed by the reaction described in equation 12-1 is in the excited state. In order to maximize chemiluminescence, the reaction cell is maintained at reduced pressure (thereby reducing the amount of available collision partners) and is supplied with a large, constant excess of ozone (about 3000-5000 ppm) from the internal ozone generator.

6.1.2. CHEMILUMINESCENCE DETECTION IN THE REACTION CELL

Chemiluminescence is detected through the use of a photomultiplier tube and an optical filter in the process of measuring and calculating gases.

6.1.2.1. THE PHOTO MULTIPLIER TUBE (PMT)

The analyzer uses a special kind of vacuum tube, called a photo-multiplier tube (PMT), to detect the amount of light created by the NO and O_3 reaction in the reaction cell.

Photons enter the PMT and strike a negatively charged photo cathode causing it to emit electrons. These electrons are accelerated by an applied high voltage and multiplied through a sequence of similar acceleration steps (dynodes) until a useable current signal is generated (see Section 6.5 for a more detailed description). The more light present (in this case photons given off by the chemiluminescent reaction described above), the more current is produced. Therefore, the more NO present in the reaction cell the more current is produced by the PMT.

The current produced by the PMT is then converted to a voltage and amplified by the preamplifier board and communicated to the analyzer's CPU via the A \rightarrow D converter circuitry on the analyzer.

6.1.2.2. OPTICAL FILTER

A high pass optical filter, only transparent to wavelengths of light above 645nm, placed between the reaction cell and the PMT (see Figure 6-1) in conjunction with the response characteristics of the PMT creates a very narrow window of wavelengths of light to which the analyzer will respond.

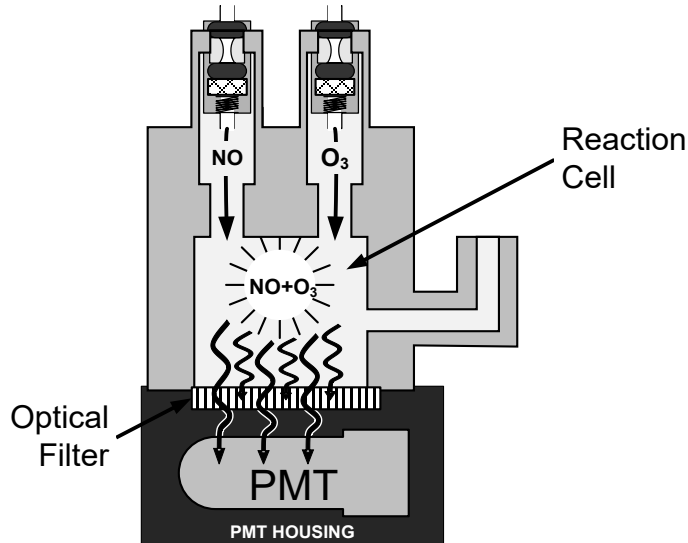

Figure 6-1. Reaction Cell with PMT Tube and Optical Filter

The narrowness of this band of sensitivity allows the analyzer to ignore extraneous light and radiation that might interfere with the analyzer's measurement. For instance, some oxides of sulfur can also be chemiluminescent emitters when in contact with O₃ but give off light at much shorter wavelengths (usually around 260nm to 480nm).

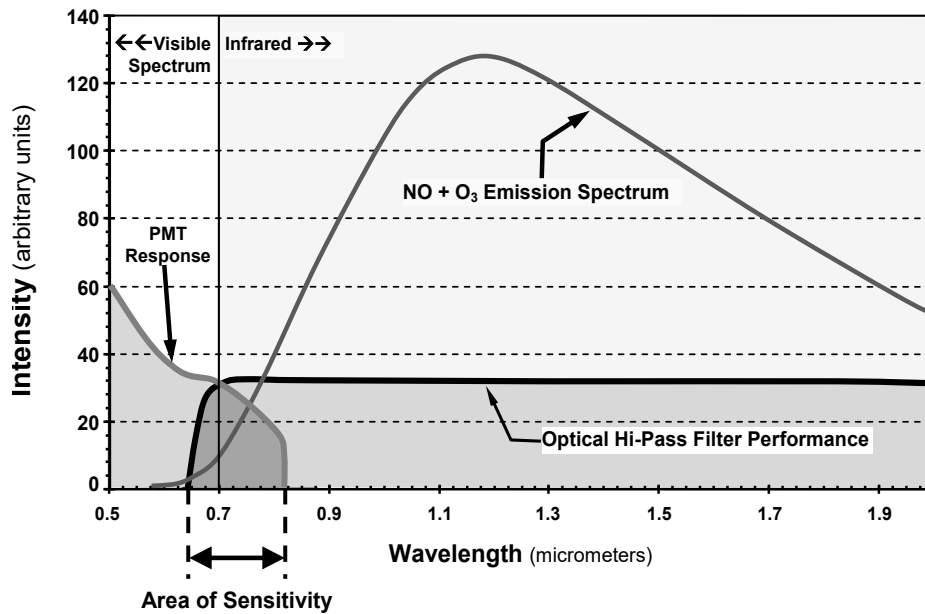

Figure 6-2. Sensitivity Spectrum

6.1.3. NO_x AND NO₂ DETERMINATION

The only gas that is actually measured by the T201 is NO. NO₂, and therefore NO_x (which is defined here as the sum of NO and NO₂ in the sample gas), contained in the gas is not detected because NO₂ does not react with O₃ to create chemiluminescence.

In order to measure the concentration of NO₂, and therefore the concentration of NO_x, the analyzer periodically switches the sample gas stream so that the pump pulls it through a special converter cartridge filled with molybdenum (“moly”) chips that are heated to a temperature of 315°C.

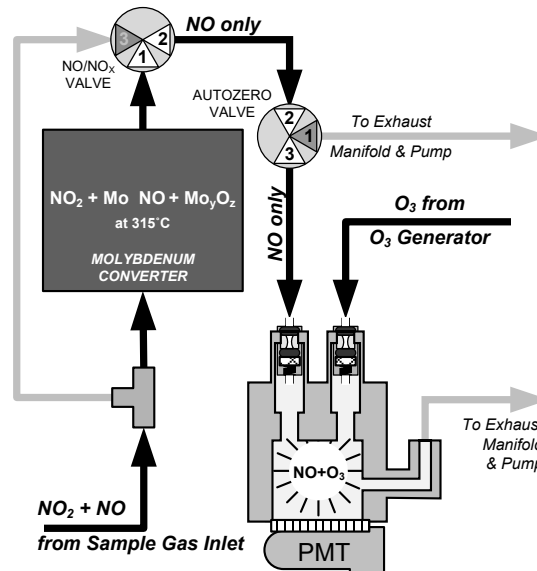
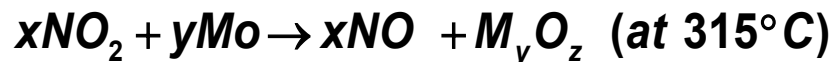

Figure 6-3. NO₂ → NO Conversion

The heated molybdenum reacts with NO₂ in the sample gas and produces a NO gas and a variety of molybdenum.

Equation 6-4



Once the NO₂ in the sample gas has been converted to NO, it is routed to the reaction cell where it undergoes the chemiluminescence reaction described in Equation 6-1 and Equation 6-2.

By converting the NO₂ in the sample gas into NO, the analyzer can measure the total NO_x content of the sample gas (i.e. the NO present + the converted NO₂ present). By switching the sample gas stream in and out of the “moly” converter every 6 - 10 seconds, the T201 analyzer is able to quasi-continuously measure both the NO and the total NO_x content.

Finally, the NO₂ concentration is not directly measured but calculated by subtracting the known NO content of the sample gas from the known NO_x content.

6.1.4. MINIMIZING PMT DRIFT: AUTO ZERO

Inherent in the operation of any PMT is a certain amount of noise. This is due to a variety of factors such as black body infrared radiation given off by the metal components of the reaction cell, unit to unit variations in the PMT units and even the constant universal background radiation that surrounds us at all times. In order to reduce this amount of noise and offset, the PMT is kept at a constant 7° C (45° F) by a Thermo-Electric Cooler (TEC).

While this intrinsic noise and offset is significantly reduced by cooling the PMT, it is not eradicated. To determine how much noise remains, once every minute for a short period the analyzer diverts the sample gas flow directly to the vacuum manifold, bypassing the reaction cell. During this period, only O₃ is present in the reaction cell, effectively turning off the chemiluminescence reaction. Once the cell is completely dark (“zero” light), the analyzer records the output of the PMT and keeps a running average of these Auto Zero (Azero) values. This average offset value is subtracted from the raw PMT readings to arrive at an Auto Zero corrected reading, thus improving zero baseline stability.

6.1.5. PURGING THE REACTION CELL

As with many chemical reactions the conversion of ammonia in the presence of other oxides of nitrogen is complicated. It is important to note that the valve DWELL time for an AZERO measurement has a default setting of 8 seconds. Shortening this value may not allow enough time to properly purge the reaction cell of excess nitric oxide from the previous measurements.

In the molybdenum converter operating at 315°C the following significant reactions are taking place:



The 501 NH₃ ammonia converter operates at 825°C. At this high temperature, several reactions occur:

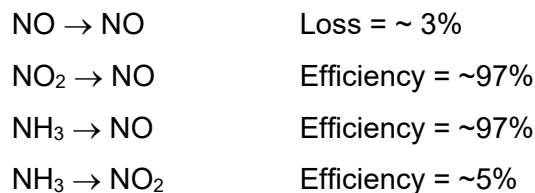

As can be seen from the above reactions, the calculation of the ammonia concentration and overall calibration of the instrument must be done carefully if accurate ammonia concentrations are to be measured.

6.1.6. MEASUREMENT INTERFERENCES

Interferences in the chemiluminescence method come from a number of sources. The analyzer has been successfully tested for its ability to reject interference from most of these sources.

6.1.6.1. DIRECT INTERFERENCE

Some gases can directly alter the amount of light detected by the PMT due to chemiluminescence in the reaction cell. This can either be a gas that undergoes chemiluminescence by reacting with O₃ in the reaction cell or a gas that reacts with other compounds and produces excess NO upstream of the reaction cell.

6.1.6.2. THIRD BODY QUENCHING

As described by Equation 6-3, other molecules in the reaction cell can collide with the excited NO₂^{*}, causing the excited NO₂^{*} to return to its ground state without releasing a photon of light. This is known as third party quenching.

Quenching is an unwanted phenomenon and the extent to which it occurs depends on the properties of the collision partner.

- Larger, more polarized molecules such as H₂O and CO₂ are the most significant quenching interferents of NO chemiluminescence.
- The influence of water vapor on the analyzer's measurement can be eliminated with an optional, internal sample gas dryer.
- The interference of varying CO₂ amounts at low concentrations (less than 0.5%) is negligible.
- In cases with excessively high CO₂ concentrations (larger than 0.5%), the effect can be calibrated out by using calibration gases with a CO₂ content equal to the measured air.
- Only very high and highly variable CO₂ concentrations will then cause a measurable interference. For those applications, it is recommended to use other analyzer models. Please consult Teledyne API's Sales Department or our website (front cover, this manual).
- Smaller less polar and electronically more stable molecules such as N₂ and O₂ can cause interference of this type as well; however, the concentrations of N₂ and O₂ are virtually constant in ambient air measurements, hence provide a constant amount of quenching that is accounted for in the calibration of the instrument .

6.1.6.3. LIGHT LEAKS

The sensitivity curve includes a small portion of the visible light spectrum (see Figure 6-2), therefore it is important to ensure that the reaction cell is completely sealed with respect to light. To ensure this:

- All pneumatic tubing leading into the reaction cell is opaque in order to prevent light from entering the cell.
- Light penetration is prevented by stainless steel filters and orifices.

6.1.6.4. REACTION CELL TEMPERATURE CONTROL

The stability of the chemiluminescence reaction between NO and O₃ can be affected by changes in the temperature and pressure of the O₃ and sample gases in the reaction cell. In order to reduce temperature effects, the reaction cell is maintained at a constant 50° C, just above the high end of the instrument's operation temperature range.

Two AC heaters, one embedded into the bottom of the reaction cell, the other embedded directly above the chamber's exhaust fitting, provide the heat source. These heaters operate off of the instrument's main AC power and are controlled by the CPU through a power relay on the relay board (see Section 6.3.3.4).

A thermistor, also embedded in the bottom of the reaction cell, reports the cell's temperature to the CPU through the thermistor interface circuitry of the motherboard (see Section 6.3.2.3).

6.2. PNEUMATIC OPERATION

Important

IMPACT ON READINGS OR DATA

The sample gas is the most critical flow path in the analyzer. At any point before and in the reaction cell, the integrity of the sample gas must not be compromised. Therefore, it is important that the sample airflow system is both leak tight and not pressurized over ambient pressure.

Regular leak checks should be performed on the analyzer as presented in the maintenance schedule, Table 5-1. Procedures for correctly performing leak checks can be found in Section 5.6.10.

6.2.1. SAMPLE GAS FLOW

Note

In this section of the manual vacuum readings are given in inches of mercury absolute (In-Hg-A). This pressure value is referenced against zero (a perfect vacuum).

The sample gas flow is created by an external vacuum pump that is located pneumatically downstream from the rest of the instrument's components.

- The pump creates a vacuum of approximately 5 in-Hg-A which is distributed to various pneumatic components by a vacuum manifold, located just in front of the rear panel (see Figure 2-4).

Gas flow is created by keeping the analyzer's sample gas inlet near ambient pressure, usually by means of a small vent installed in the sample line at the inlet, in effect pulling the gas through the instrument's pneumatic systems.

By placing the pump downstream from the analyzer's reaction cell, several problems are avoided.

- First, the pumping process heats and compresses the sample air complicating the measurement process.
- Additionally, certain physical parts of the pump itself are made of materials that might chemically react with the sample gas.
- Finally, in certain applications where the concentration of the target gas might be high enough to be hazardous, maintaining a negative gas pressure relative to ambient means that should a minor leak occur, no sample gas would be pumped into the atmosphere surrounding the analyzer.

6.2.1.1. VACUUM MANIFOLD

The vacuum created by the analyzer's pump is supplied to all of the gas streams for the analyzer through the vacuum manifold (also called the exhaust manifold).

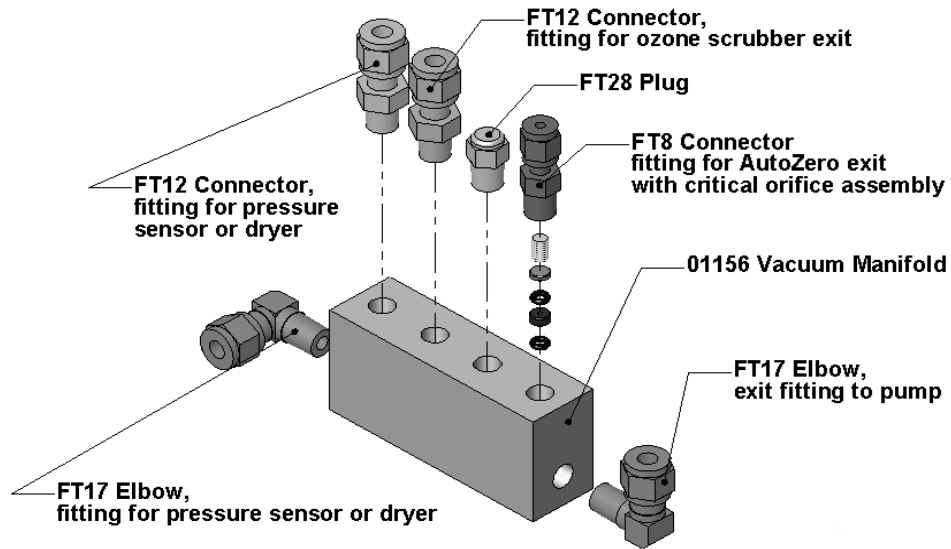

Figure 6-4. Vacuum Manifold, Standard Configuration

Configurations will vary depending on the optional equipment that is installed. For example:

- An optional internal span gas generator installed will add another FT8 connector and orifice assembly to the manifold where the FT28 fitting is as shown in the above drawing.
- An optional sample gas dryer will add a Tee-fitting so that two ¼" tubes can be connected to the same port.

6.2.1.2. SAMPLE GAS FLOW VALVES AND ROUTING

The measurement of TN_x, NH₃, NO_x, NO and NO₂ requires that the sample gas flow cycles through different states that include and exclude various scrubbers and converters. There are several valves that perform this function, as indicated in Table 6-1, below.

Table 6-1. Valve Cycle Phases

PHASE	TN/TNX VALVE STATUS	AUTO ZERO VALVE STATUS	NO/ NOX VALVE STATUS	TIME INDEX	ACTIVITY
TN _x Measure	ON	OFF	ON	0 – 4 s	Wait period for TN _x measurement
				4 – 8 s	Analyzer reads the TN _x measurement.
NO _x Measure	OFF	OFF	ON	8 – 12 s	Wait period (NO dwell time). Ensures reaction cell has been flushed of previous gas.
				12 – 16 s	Analyzer measures chemiluminescence in reaction cell.
NO Measure	OFF	OFF	OFF	16 – 20 s	Wait period (NO _x dwell time). Ensures reaction cell has been flushed of previous gas.
				20 – 24 s	Analyzer measures NO + O ₃ chemiluminescence in reaction cell.
Cycle repeats every ~24 seconds for two times (total 48 seconds), and then enters Auto Zero Phase for 12 seconds					
Auto Zero	OFF	ON	OFF	0 – 4 s	Wait period (AZERO pre-dwell time). Ensures reaction cell has been flushed of sample gas and chemiluminescence reaction is stopped.
				4 – 6 s	Analyzer measures background noise without sample gas, and re-zeros the PMT's mV reading.
Post Auto Zero	OFF	OFF	OFF	6 – 12 s	Wait period (AZERO post-dwell time). Ensures sample gas is reintroduced so that chemiluminescence reaction is restarted before returning to the TN _x Measure phase.
Cycle repeats every minute.					

6.2.2. FLOW RATE CONTROL - CRITICAL FLOW ORIFICES

Sample gas flow in the analyzer is created via the use of several flow control assemblies (see Figure 6-5 for an example) located in various places in the gas streams of the instrument. These assemblies consist of:

- a critical flow orifice
- two o-rings, Located just before and after the critical flow orifice, the o-rings seal the gap between the walls of assembly housing and the critical flow orifice
- a sintered filter
- a spring (applies mechanical force needed to form the seal between the o-rings, the critical flow orifice and the assembly housing)

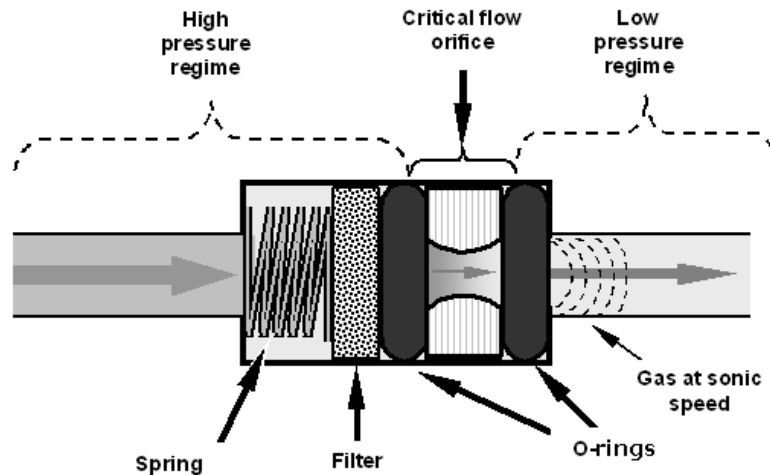

Figure 6-5. Flow Control Assembly & Critical Flow Orifice

6.2.2.1. CRITICAL FLOW ORIFICE

The most important component of each flow control assembly is the critical flow orifice. Critical flow orifices are a simple means to regulate stable gas flow rates. They operate without moving parts by taking advantage of the laws of fluid dynamics. By restricting the flow of gas through the orifice, a pressure differential is created. This pressure differential, created by the analyzer's external pump, draws the gas through the orifice.

As the pressure on the downstream side of the orifice (the pump side) continues to drop, the speed that the gas flows through the orifice continues to rise. Once the ratio of upstream pressure to downstream pressure is greater than 2:1, the velocity of the gas through the orifice reaches the speed of sound. As long as that ratio stays at least 2:1, the gas flow rate is unaffected by any fluctuations, surges, or changes in downstream pressure because such variations only travel at the speed of sound themselves and are therefore cancelled out by the sonic shockwave at the downstream exit of the critical flow orifice.

The actual flow rate of gas through the orifice (volume of gas per unit of time), depends on the size and shape of the aperture in the orifice. The larger the holes, the more gas molecules (moving at the speed of sound) pass through the orifice.

In addition to controlling the gas flow rates into the reaction cell, the two critical flow orifices at the inlets of the reaction cell also maintain an under-pressure inside it, effectively reducing the number of molecules in the chamber and the corresponding incidence of third body quenching (see Section 6.1.6.2), and thereby increasing the chemiluminescence yield.

- The analyzer reaches its peak sensitivity at about 2 in-Hg-A, below which the sensitivity drops due to there being too few molecules present and a corresponding decrease in chemiluminescence.

6.2.2.2. LOCATIONS AND DESCRIPTIONS OF CRITICAL FLOW ORIFICES

Several critical flow orifices (Figure 6-6) are used to create and maintain the proper flow rate of gas through its various components. (Please note that Figure 6-6 represents the standard configuration and is provided for reference).

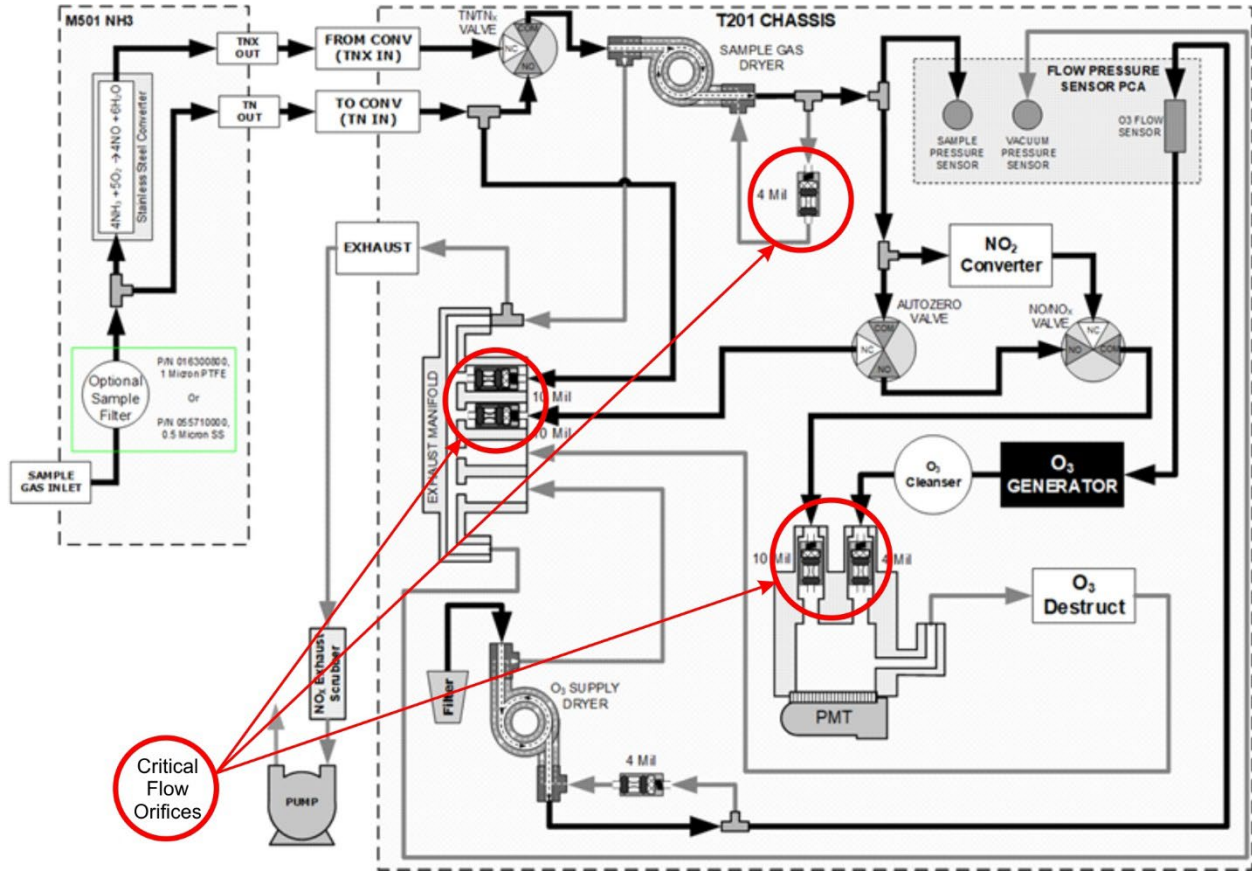

Figure 6-6. Location of Flow Control Assemblies & Critical Flow Orifices

The necessary 2:1 ratios across the critical flow orifices is largely exceeded by the pumps supplied with the analyzer which are designed to accommodate a wide range of possible variability in atmospheric pressure and age related degradation of the pump itself. Once the pump does degrade, the ratio between sample and vacuum pressures may fall to less than 2:1. At this point, the instrument will display an invalid sample flow rate measurement.

Note

The diameter of a critical flow orifice may change with temperature because of expansion of the orifice material and, hence, the most crucial critical flow orifices (those controlling the sample gas and O₃ flow into the cell itself) are located in the reaction cell where they can be maintained at a constant temperature.

6.2.3. OZONE GAS GENERATION AND AIR FLOW

The excess ozone needed for reaction with NO in the reaction cell is generated inside the analyzer because of the instability and toxicity of ozone. Besides the ozone generator itself, this requires a dry air supply and filtering of the gas before it is introduced into the reaction cell.

Due to its toxicity and aggressive chemical behavior, O₃ must also be removed from the gas stream before it can be vented through the exhaust outlet.

CAUTION – GENERAL SAFETY HAZARD



Ozone (O₃) is a toxic gas.

Obtain a Material Safety Data Sheet (MSDS) for this gas. Read and rigorously follow the safety guidelines described there.

Always ensure that the plumbing of the O₃ generation and supply system is maintained and leak-free.

6.2.3.1. THE O₃ GENERATOR

The analyzer uses a dual-dielectric, Corona Discharge (CD) tube for creating its O₃, which is capable of producing high concentrations of ozone efficiently and with low excess heat (see Figure 6-7). The primary component of the generator is a glass tube with hollow walls of which the outermost and innermost surfaces are coated with electrically conductive material.

Air flows through the glass tube, between the two conductive coatings, in effect creating a capacitor with the air and glass acting as the dielectric. The layers of glass also separate the conductive surfaces from the air stream to prevent reaction with the O₃. As the capacitor charges and discharges, electrons are created and accelerated across the air gap and collide with the O₂ molecules in the air stream splitting them into elemental oxygen.

Some of these oxygen atoms recombine with O₂ to O₃. The quantity of ozone produced is dependent on factors such as the voltage and frequency of the alternating current applied to the CD cells. When enough high-energy electrons are produced to ionize the O₂ molecules, a light emitting, gaseous plasma is formed, which is commonly referred to as a corona, hence the name corona discharge generator.

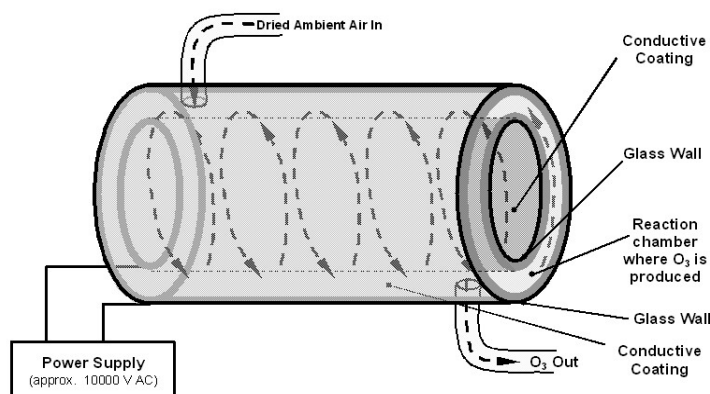

Figure 6-7. Ozone Generator Principle

6.2.3.2. OZONE GENERATOR DRY AIR SUPPLY

Ambient air usually contains enough water vapor to greatly diminish the yield of ozone produced by the ozone generator. Water also reacts with chemicals inside the O₃ Generator to produce caustic substances such as ammonium sulfate or highly corrosive nitric acid that will damage the optical filter located between the reaction cell and the PMT.

To prevent this, the air supply for the O₃ generator is dried using a special single tube permeation dryer. The dryer consists of a single tube of Nafion[®] that is mounted within an outer, flexible plastic tube. Nafion[®] is a co-polymer that absorbs water very well but not most other chemicals. As gas flows through the inner Nafion[®] tube, water vapor is absorbed into the membrane walls. The absorbed water is transported through the membrane wall and evaporated into the dry purge gas flowing through the outer tube, countercurrent to the gas in the inner tube.

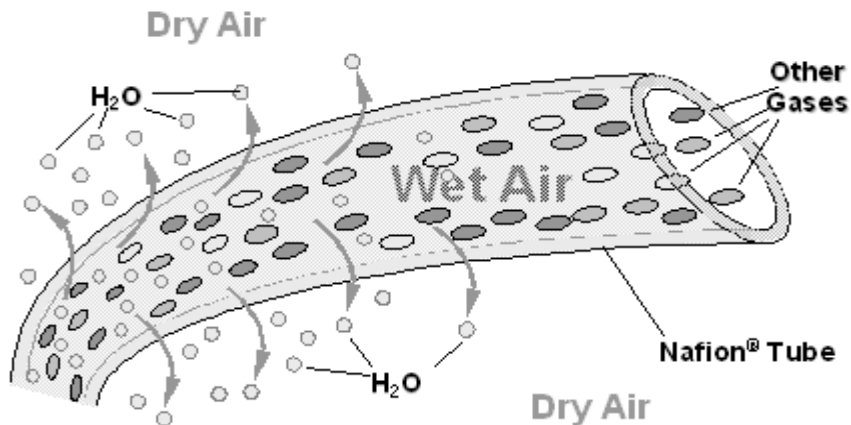

Figure 6-8. Semi-Permeable Membrane Drying Process

The process by which the water vapor molecules are collected and transported through Nafion[®] material is called per-evaporation and is driven by the humidity gradient between the inner and outer tubes as well as the flow rates and pressure difference between inner and outer tubing. Unlike micro-porous membrane permeation, which transfers water through a relatively slow diffusion process, per-evaporation is a simple kinetic reaction. Therefore, the drying process occurs quickly, typically within milliseconds.

Because this chemical reaction is based on hydrogen bonds between the water molecule and the Nafion[®] material most other chemical components of the gas to be dried are usually unaffected. Specifically, the gases of interest, NO and NO₂, do not get absorbed and pass the dryer unaltered.

On the other hand, other small polar gases that are capable of hydrogen bonds such as ammonia (NH₃) can be absorbed this way, too. This is an advantage since gases such as NH₃ can cause interference for the measurement of NO_x, NO and NO₂.

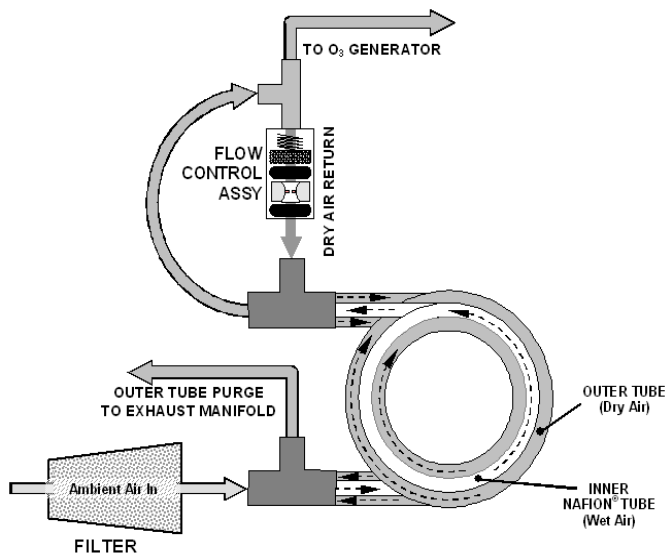

Figure 6-9. Sample Dryer

To provide a dry purge gas for the outer side of the Nafion[®] tube, the analyzer returns some of the dried air from the inner tube to the outer tube. This means that any time the analyzer

is turned on after having been OFF for 30 minutes or more, the humidity gradient between the inner and outer tubes is not very large and the dryer's efficiency is low. It takes a certain amount of time for the humidity gradient to become large enough for the Sample Dryer operate efficiently, in such cold start cases the O₃ Generator is not turned on until 30 minutes has passed in order to ensure that it is not operating until its air supply is properly dry.

Note

When rebooting the instrument within less than 30 minutes of power-down, the generator is turned on immediately.

The Sample Dryer is capable of adequately drying ambient air to a dewpoint of $\leq -5^{\circ}\text{C}$ (~ 4000 ppm residual H₂O) at a flow rate of 1 standard liter per minute (slpm) or down to $\leq -15^{\circ}\text{C}$ (~ 1600 ppm residual H₂O) at 0.5 slpm. The Sample Dryer is also capable of removing ammonia from the sample gas up to concentrations of approximately 1 ppm.

6.2.3.3. OZONE SUPPLY AIR FILTER

The analyzer uses ambient air as the supply gas for the O₃ generator and may produce a variety of byproducts. Small amounts of water, ammonia and various sulfur oxides can combine to create ammonium sulfate, ammonium nitrate, nitric acid and other compounds. Whereas sulfates and nitrates can create powdery residues inside the reaction cell causing sensitivity drift, nitric acid is a very aggressive compound, which can deteriorate the analyzer's components. In order to remove these chemical byproducts from the O₃ gas stream, the output of the O₃ generator flows through a special filter between the generator and the reaction cell.

The small amount of NO_x produced in the generator (from the reaction of O₂ or O₃ and N₂ in the air) will not affect the analyzer's ability to measure NO_x, NO and NO₂ as it is accounted for and removed from the concentration calculations by the analyzer's Auto Zero feature (see Section 6.1.4).

6.2.3.4. OZONE DESTRUCT

Even though ozone is unstable and typically reacts to form O₂, the break-down is not quite fast enough to ensure that it is completely removed from the exhaust gas stream by the time the gas exits the analyzer. Due to the high toxicity and reactivity of O₃, a highly efficient catalytic converter scrubs or converts all of the O₃ from the gas exiting the reaction cell. The conversion process is very safe. It only converts ozone to oxygen and does not produce any toxic or hazardous gases.

The O₃ destruct is located just inside the NO₂ converter. As this is a true catalytic converter, there are no maintenance requirements as would be required for charcoal-based ozone destructs.

A certain amount of fine, black dust may exit the catalyst, particularly if the analyzer is subjected to sudden pressure drops (for example, when disconnecting the running pump without letting the analyzer properly and slowly equilibrate to ambient pressure). To prevent the dust from entering the reaction cell or the pump, the ozone destruct is equipped with a quartz wool filter material.

6.2.4. PNEUMATIC SENSORS

Note

The analyzer displays all pressures in inches of mercury absolute (in-Hg-A), i.e. absolute pressure referenced against zero (a perfect vacuum).

Three pneumatic sensors verify the flow and pressure levels of the gas streams. They are located on a printed circuit assembly, called the pneumatic pressure/flow sensor board, located just behind the sensor assembly. The measurements made by these sensors are used for a variety of important calculations and diagnostics.

6.2.4.1. SAMPLE PRESSURE SENSOR

An absolute pressure transducer connected to the input of the NO/NO_x valve is used to measure the pressure of the sample gas before it enters the analyzer's reaction cell.

- In conjunction with the measurement made by the vacuum pressure sensor, this "upstream" measurement is used to compute the sample gas sample flow rate and to validate the critical flow condition (2:1 pressure ratio) through the sample gas critical flow orifice (Section 6.2.2).
- If the Temperature/Pressure Compensation (TPC) feature is turned on (Section 6.9.2), the output of this sensor is also used to supply pressure data for that calculation.

6.2.4.2. VACUUM PRESSURE SENSOR

An absolute pressure transducer connected to the exhaust manifold is used to measure the pressure downstream from and inside the instrument's reaction cell.

- The output of the sensor is used by the CPU to calculate the pressure differential between the gas upstream of the reaction cell and the gas downstream from it and is also used as the main diagnostic for proper pump operation.
- If the ratio between the upstream pressure and the downstream pressure falls below 2:1, an Alert is triggered, and the sample flow rate will not display an actual value.
- If this pressure exceeds 10 in-Hg-A, an Rx Press Alert is issued, even though the analyzer will continue to calculate a sample flow up to ~14 in Hg.
- If the Temperature/Pressure Compensation (TPC) feature is turned on (see Section 6.9.2), the output of this sensor is also used to supply pressure data for that calculation.

6.2.4.3. SAMPLE GAS FLOW CALCULATION

Sample gas flow in the analyzer is not a directly measured value, but is rather calculated based on the measured pressure differential across the sample gas critical flow orifice. Specifically, the upstream reading of the sample pressure sensor is compared to the downstream pressure reading of the vacuum pressure sensor, and this differential is used by the analyzer's CPU to derive the gas flow rate through the reaction cell.

- The results of this calculation are viewable in the Dashboard and/or in the Home page meter if configured to display Sample Flow. (To configure, see Section 2.5.3 for Dashboard, and Section 2.5.6 for Home page meter).

6.2.4.4. O₃ SUPPLY AIR FLOW SENSOR

In contrast to the sample gas flow, the ozone flow is measured with a mass flow sensor, which is mounted on the flow/pressure sensor PCA just behind the PMT sensor assembly. Pneumatically, it lies between the sample dryer and the O₃ generator. This mass flow sensor has a full scale range of 0-1000 cc/min and can be calibrated through software to its span point (Section 4.5).

Since the flow value displayed on the front panel is an actual measurement (and not a calculated value), short term variability in the measurement may be higher than that of the sample flow, which is based on a calculation from (more stable) differential pressures. On the other hand, any sustained drift, i.e. long-term change, in the ozone flow rate may usually indicate a flow problem.

This information is used to validate the O₃ gas flow rate.

- If the flow rate exceeds $\pm 15\%$ of the nominal flow rate (80 cc/min), an O₃ Flow message appears in the Alerts page, and the O₃ generator is turned off, triggering a corresponding message in the Alerts page.
- The value for this flow measurement is viewable as O₃ Flow.

As with all other test parameters, we recommend to monitor the ozone flow over time for predictive diagnostics and maintenance evaluation.

6.3. ELECTRONIC OPERATION

The core of the analyzer is a microcomputer/central processing unit (CPU) that controls various internal processes, interprets data, makes calculations, and reports results using specialized firmware developed by Teledyne API. It communicates with the user as well as receives data from and issues commands to a variety of peripheral devices via a separate printed circuit assembly onto which the CPU is mounted: the motherboard.

The motherboard is directly mounted to the inside rear panel and collects data, performs signal conditioning duties and routes incoming and outgoing signals between the CPU and the analyzer's other major components.

Data are generated by the sensor module which outputs an analog signal corresponding to the amount of chemiluminescence present in the reaction cell. This signal is converted into digital data by a unipolar, analog-to-digital converter, located on the motherboard.

A variety of sensors report the physical and operational status of the analyzer's major components, again through the signal processing capabilities of the motherboard. These status reports are used as data for the various concentration calculations and as trigger events for certain warning messages and control commands issued by the CPU. This information is stored in memory by the CPU and in most cases can be viewed by the user via the front panel display.

The CPU issues commands via a series of relays and switches (also over the I²C bus) located on a separate printed circuit assembly, called the Relay PCA, to control the function of key electromechanical devices such as heaters and valves. It also issues some commands directly to the Sensor module (e.g. initiate Electric Test or Optical Test).

By controlling the state of various valves the CPU directs the flow of sample gas through the various gas paths of the analyzer (NO measurement path; NO_x measurement path; Auto Zero Path). Based on which path is active, the CPU interprets the sensor output to derive raw data representing concentrations for NO_x, NO and zero (dark condition), accesses the operational data stored in memory then calculates final concentrations for NO_x, NO and NO₂.

The CPU communicates with the user and the outside world in several ways:

- Through the analyzer's front panel LCD touch-screen interface
- Through the serial I/O channels
- Various analog voltage and current outputs
- Several sets of Digital I/O channels
- Ethernet

6.3.1. CPU

The unit's CPU card, installed on the motherboard located inside the rear panel, is a low power (5 VDC, 720mA max), high performance, Vortex86SX-based microcomputer running Windows CE. Its operation and assembly conform to the PC 104 specification. The CPU includes two types of non-volatile data storage: a Disk-on-Module (DOM) and an embedded flash chip. The DOM is a 44-pin IDE flash drive with storage a 512 MB capacity. It is used to store the computer's operating system, the Teledyne API firmware, and most of the operational data generated by the analyzer's internal data acquisition system (DAS). The non-volatile, embedded flash chip includes 2MB of storage for calibration data as well as a backup of the analyzer configuration.

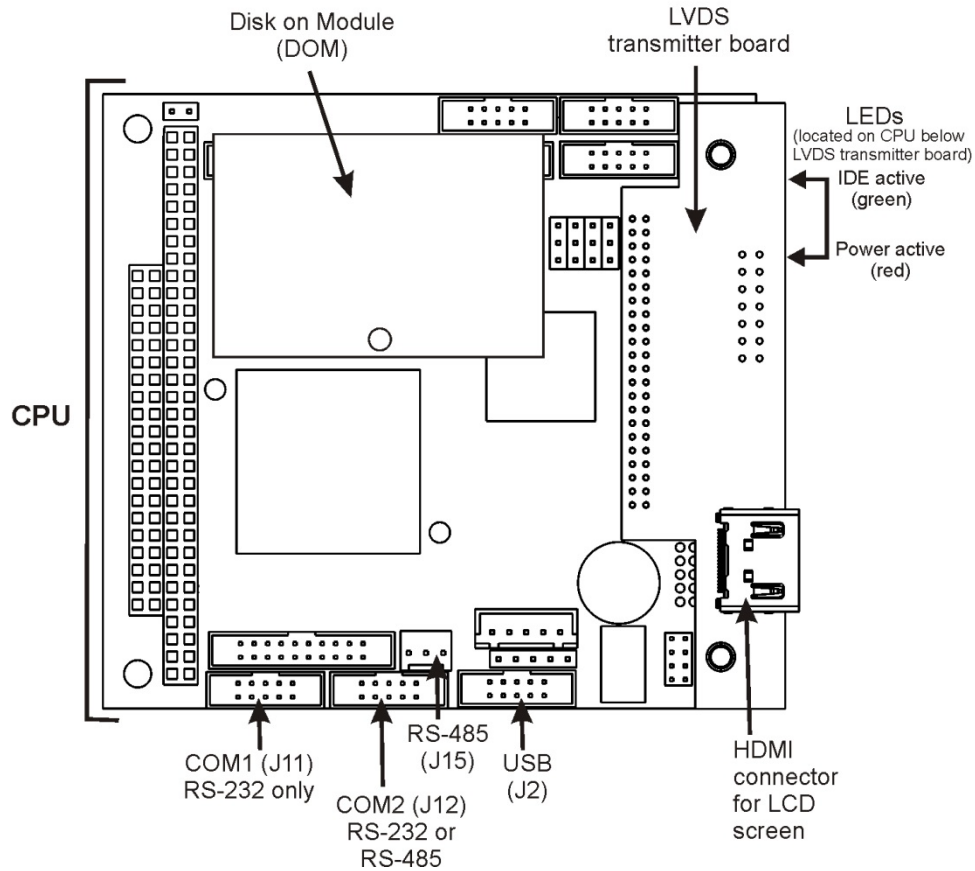

Figure 6-10. CPU Board

6.3.2. MOTHERBOARD

This PCA provides a multitude of functions including, A/D conversion, digital input/output, PC-104 to I²C translation, temperature sensor signal processing and is a pass through for the RS-232 and RS-485 signals.

6.3.2.1. A TO D CONVERSION

Analog signals, such as the voltages received from the analyzer's various sensors, are converted into digital signals that the CPU can understand and manipulate by the analog to digital (A/D) converter. Under the control of the CPU, this functional block selects a particular signal input and then converts the selected voltage into a digital word.

The A/D converter consists of a Voltage-to-Frequency (V-F) converter, a Programmable Logic Device (PLD), three multiplexers, several amplifiers and other associated devices. The V-F converter produces a frequency proportional to its input voltage. The PLD counts the output of the V-F during a specified time, and sends the result of that count, in the form of a binary number, to the CPU.

The A/D can be configured for several different input modes and ranges, but in this analyzer it is used in unipolar mode with a +5V full scale. The converter includes a 1% over and under-range. This allows signals from -0.05V to +5.05V to be fully converted.

For calibration purposes, two reference voltages are supplied to the A/D converter: Reference ground and +4.096 VDC. During calibration, the device measures these two voltages, outputs their digital equivalent to the CPU. The CPU uses these values to compute the converter's offset and slope and uses these factors for subsequent conversions.

6.3.2.2. SENSOR INPUTS

The key analog sensor signals are coupled to the A/D through the master multiplexer from two connectors on the motherboard. 100K terminating resistors on each of the inputs prevent cross talk from appearing on the sensor signals.

PMT DETECTOR OUTPUT: The PMT detector output from the PMT preamplifier is used in the computation of the NO, NO_x, NO₂ and TN_x, NH₃ concentrations displayed in the Dashboard and reported through the instrument's analog outputs and COM ports.

HIGH VOLTAGE POWER SUPPLY (HVPS) LEVEL: The PMT high voltage is based on the drive voltage from the preamplifier board. It is digitized and sent to the CPU which then calculates the voltage setting of the HVPS.

PMT TEMPERATURE: The PMT temperature is measured with a thermistor inside the PMT cold block. Its signal is amplified by the PMT temperature feedback circuit on the preamplifier board and is digitized and sent to the CPU which calculates the current temperature of the PMT.

SAMPLE GAS PRESSURE SENSOR: Located on the flow/pressure sensor PCA, this sensor measures the sample chamber's gas pressure.

VACUUM PRESSURE SENSOR: Also located on the flow/pressure sensor PCA, this sensor measures the pressure of the gas mixture inside the reaction cell.

O₃ FLOW SENSOR: Located on the flow/pressure sensor PCA as well, this sensor measures the flow rate of the O₃ gas stream as it is supplied to the reaction cell.

6.3.2.3. THERMISTOR INTERFACE

This circuit provides excitation, termination and signal selection for several negative coefficient, thermistor temperature sensors located inside the analyzer.

REACTION CELL TEMPERATURE (Rx Cell Temp) SENSOR: A thermistor that measures the temperature inside the reaction cell manifold, which is used by the CPU to control the reaction cell heating circuit and as a parameter in the temperature/pressure compensation algorithm.

BOX TEMPERATURE (Box Temp) SENSOR: A thermistor that measures the analyzer's inside temperature, which is then reported through the front panel display. It is also used as part of the NO, NO_x and NO₂ calculations when the instrument's Temperature/Pressure Compensation feature is enabled (Setup>Vars>TPC Enable).

INTERNAL SPAN GAS GENERATOR (Option) OVEN_TEMPERATURE: This thermistor reports the temperature of the optional internal span gas generator's NO₂ permeation source to the CPU as part of a control loop that keeps the tube at a high constant temperature (necessary to ensure that the permeation rate of NO₂ is constant).

Note

There are two thermistors that monitor the temperature of the PMT assembly:

One is embedded in the cold block of the PMT's TEC. Its signal is conditioned by the PMT preamplifier PCA and reported to the CPU via the motherboard (see Section 6.3.2.2).

The second is located on the PMT Preamplifier PCA and is used only as a reference for the preamplifier circuitry. Its output is neither reported nor stored.

6.3.2.4. ANALOG OUTPUTS

The analyzer comes equipped with four configurable analog outputs on the instrument's rear panel analog connector, labeled A1, A2, A3 and A4. A variety of scaling measurement and electronic factors apply to these signals.

OUTPUT LOOP-BACK: All of the functioning analog outputs are connected back to the A/D converter through a Loop-back circuit. This permits the voltage outputs to be calibrated by the CPU without need for any additional tools or fixtures.

6.3.2.5. EXTERNAL DIGITAL I/O

The external digital I/O controls the Status Outputs and the Control Inputs.

6.3.2.6. INTERNAL DIGITAL I/O

The internal Digital I/O controls some subsystems, such as the electrical and optical tests, the PMT preamplifier range control, and the O₃ generator.

6.3.2.7. I²C DATA BUS

I²C is a two-way, clocked, bi-directional digital serial I/O bus that is used widely in commercial and consumer electronic systems. A transceiver on the Motherboard converts data and control signals from the PC-104 bus to I²C format. The data are then fed to the relay board and valve driver board circuitry.

6.3.2.8. POWER-UP CIRCUIT

This circuit monitors the +5V power supply during start-up and sets the analog outputs, external digital I/O ports, and I²C circuitry to specific values until the CPU boots and the instrument software can establish control.

6.3.3. RELAY PCA

The CPU issues commands via a series of relays and switches located on a separate printed circuit assembly, called the Relay PCA (Figure 6-11), to control the function of key electromechanical devices such as heaters and valves. The Relay PCA receives instructions in the form of digital signals over the I²C bus, interprets these digital instructions and activates its various switches and relays appropriately.

The Relay PCA is located in the right-rear quadrant of the analyzer and is mounted vertically on the backside of the same bracket as the instrument's DC power supplies.

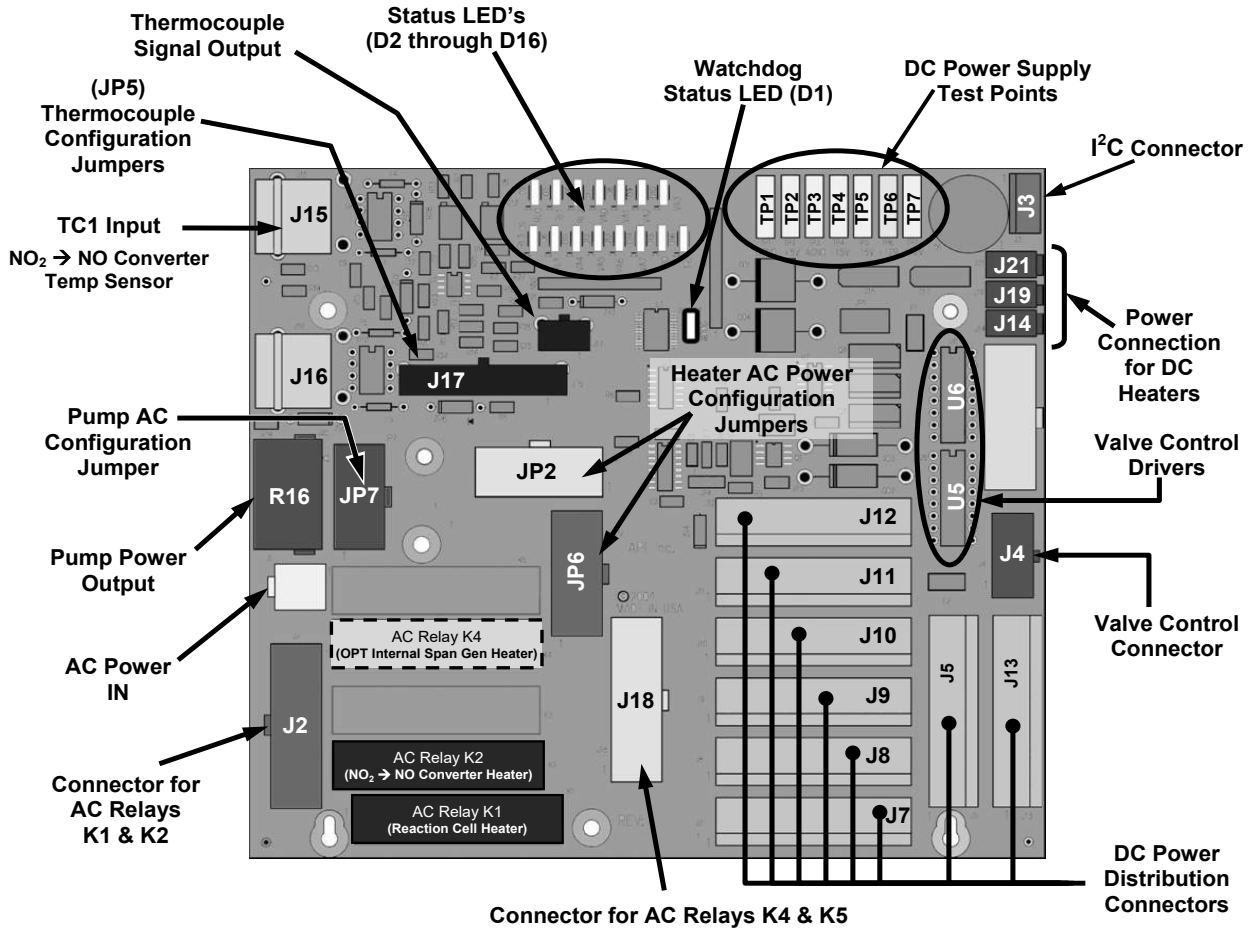

Figure 6-11. Relay PCA Layout (P/N 045230100)

WARNING – ELECTRICAL SHOCK HAZARD

Only those relays actually required by the configuration of the analyzer are populated.



A protective retainer plate is installed over the AC power relays to keep them securely seated in their sockets and prevent accidental contact with those sockets that are not populated see Figure 6-12).

Never remove this retainer while the instrument is plugged in and turned on. The contacts of the AC relay sockets beneath the shield carry high AC voltages even when no relays are present.

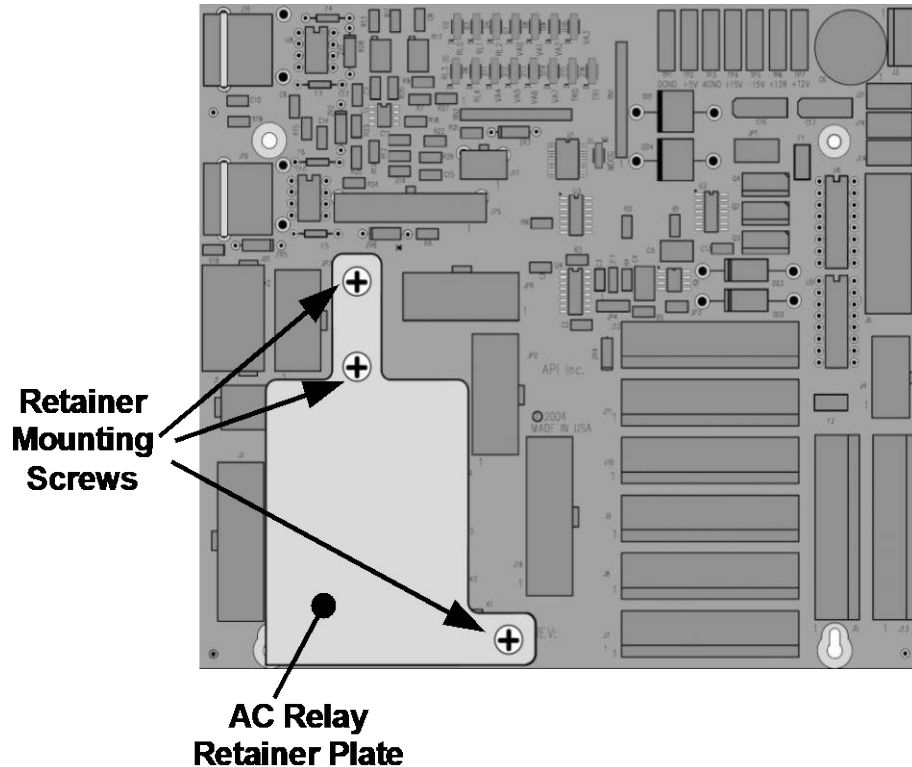

Figure 6-12. Relay PCA P/N 045230100 with AC Relay Retainer in Place

6.3.3.1. STATUS LED'S

LEDs located on the analyzer's Relay PCA show the current status on the various control functions performed by the Relay PCA. Their on/off states, functions and fault descriptions were presented in Table 5-7.

6.3.3.2. WATCHDOG CIRCUITRY

The most important of the status LED's on the relay board is the red I²C bus watch-dog LED. It is controlled directly by the analyzer's CPU over the I²C bus. Special circuitry on the Relay PCA watches the status of D1. Should this LED ever stay ON or OFF for 30 seconds, indicating that the CPU or I²C bus has stopped functioning, this Watchdog Circuit automatically shuts all valves and turns off all heaters.

6.3.3.3. VALVE CONTROL

The relay board also hosts valve driver chips, each of which can drive up to four valves. The valve assemblies include the NO/NO_x TN_x/TN_x, Auto-Zero, Sample, Zero, and Span valves. These valves are actuated with 12 V supplied from the relay board and under the control of the CPU through the I²C bus.

6.3.3.4. HEATER CONTROL

For a variety of reasons, such as efficiency of certain chemical reactions, stabilization of sample gas temperature and pressure, etc., various subcomponents are heated/cooled.

Two types of sensors are used to gather temperature data for the CPU:

- **THERMISTORS:** These are used in areas where the temperature control point is at or near ambient temperature (e.g. the reaction cell temperature, internal chassis temperate).
 - Thermistors change resistance as they heat up and cool down. A DC signal is sent from the Mother board of a set voltage and current. As the thermistor changes resistance, the returning voltage rises and falls in direct relationship to the change in temperature.
 - The output signal from the thermistors is received by the motherboard, converted into digital data which is forwarded to the CPU.
- **THERMOCOUPLES:** These are used where the target temperature is high.
 - Thermocouples generate DC voltage that rises and falls as the thermocouple heats up and cools down.
 - This DC signal is interpreted, conditioned and amplified by the Relay PCA then transmitted to the motherboard where it is also converted into digital data and forwarded to the CPU.

All of the heaters used are AC powered which are turned ON/OFF by AC relays located on the Relay PCA in response to commands issued by the CPU.

Note

The PMT temperature is maintained by a separate control loop that does not involve the relay PCA (see Section 6.5.2).

6.3.3.5. THERMOCOUPLE INPUTS AND CONFIGURATION JUMPER (JP5)

Although the Relay PCA supports two thermocouple inputs, these analyzers only utilize one. It is used to sense the temperature of the Ozone Destruct.

- This single thermocouple input is plugged into the TC1 input (J15).
- TC2 (J16) is currently not used (see Figure 6-11 for location of J15 and J16).
- The type and operating parameters of this thermocouple are set using a jumper plug (JP5).

The default configuration for this thermocouple is:

- Type-K
- Temperature compensated for Type-K
- Isolated

Table 6-2. Thermocouple Configuration Jumper (JP5) Pin-Outs

TC INPUT	JUMPER PAIR	DESCRIPTION	FUNCTION
TC1	1 – 11	Gain Selector	Selects preamp gain factor for J or K TC OUT = K TC gain factor; IN = J TC gain factor
	2 – 12	Output Scale Selector	Selects preamp gain factor for J or K TC OUT = 10 mV / °C; IN = 5 mV / °C
	3 – 13	Type J Compensation	When present, sets Cold Junction Compensation for J type Thermocouple
	4 – 14	Type K Compensation	When present, sets Cold Junction Compensation for K type Thermocouple
	5 – 15	Termination Selector	Selects between Isolated and grounded TC IN = Isolate TC; OUT = Grounded TC
TC2	NOT USED		

ATTENTION

COULD DAMAGE INSTRUMENT AND VOID WARRANTY
 The correct Thermocouple Type must be used if there is ever the need for replacement. If in doubt, please consult Teledyne API Technical Support.

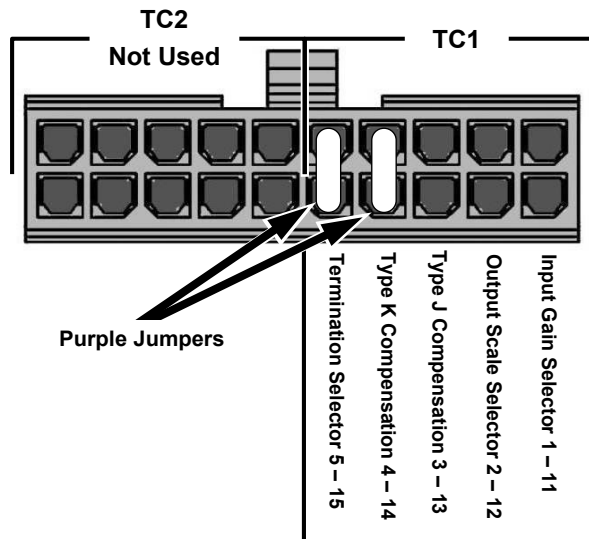

Figure 6-13. Thermocouple Configuration Jumper (JP5) Pin-Outs

6.4. SENSOR MODULE

The sensor assembly (Figure 5-23) consists of several subassemblies, each with different tasks:

- The Photo Multiplier Tube (PMT) detects the intensity of the light from the chemiluminescence reaction between NO and O₃ in the reaction cell. It outputs a current signal that varies in relationship with the amount of light in the reaction cell.
- The PMT Preamplifier PCA converts the current output by the PMT into a voltage and amplifies it to a signal strong enough to be usable by the motherboard's A → D converter. It also supplies the drive voltage and gain adjustment for the PMT's High Voltage Power Supply (HVPS)
- The Thermo-Electric Cooler (TEC) controls the temperature of the PMT to ensure the accuracy and stability of the measurements.

6.5. PHOTO MULTIPLIER TUBE (PMT)

The analyzers use a photo multiplier tube (Figure 5-23) to detect the amount of chemiluminescence created in the Reaction Cell.

A typical PMT is a vacuum tube containing a variety of specially designed electrodes. Photons from the reaction are filtered by an optical high-pass filter, enter the PMT and strike a negatively charged photo cathode causing it to emit electrons. A high voltage potential across these focusing electrodes directs the electrons toward an array of high voltage dynodes.

The dynodes in this electron multiplier array are designed so that each stage multiplies the number of emitted electrons by emitting multiple, new electrons. The greatly increased numbers of electrons emitted from one end of the electron multiplier are collected by a positively charged anode at the other end, which creates a useable current signal. This current signal is amplified by the preamplifier board and then reported to the motherboard.

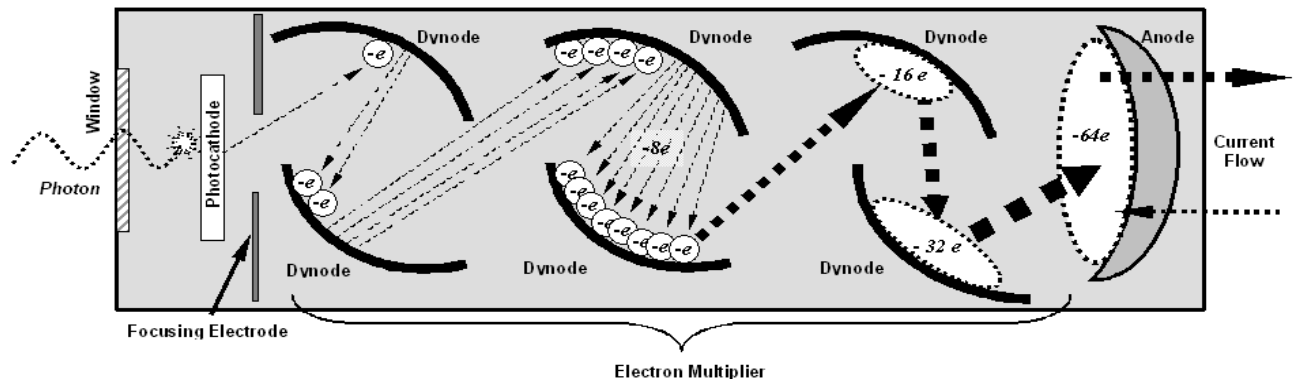

Figure 6-14. Basic PMT Design

A significant performance characteristic of the PMT is the voltage potential across the electron multiplier. The higher the voltage, the greater the number of electrons emitted from each dynode of the electron multiplier, in effect, making the PMT more sensitive and responsive to smaller variations in light intensity, but also more noisy (this is referred to as “dark noise”).

- The gain voltage of the PMT is usually set between 400 V and 800 V.
- This parameter is viewable in the Dashboard as HVPS.
- For information on when and how to set this voltage, see Section 5.7.10.4.

The PMT is housed inside the PMT module assembly (see Figure 5-23). This assembly also includes the high voltage power supply required to drive the PMT, an LED used by the instrument’s optical test function, a thermistor that measures the temperature of the PMT and various components of the PMT cooling system including the TEC.

6.5.1. PMT PREAMPLIFIER

The PMT preamplifier board provides a variety of functions:

- Amplifies the PMT Signal into a useable analog voltage that can be processed by the motherboard into a digital signal to be used by the CPU to calculate the NO, NO₂ and NO_x concentrations of the gas in the sample chamber.
- Supplies the drive voltage for the HVPS.
- Includes the circuitry for switching between the two physical ranges.
- Amplifies the signal output by the PMT Temperature sensor and feeds it back to the thermoelectric cooler driver PCA. This amplified signal is also sent to the Motherboard to be digitized and forwarded to the CPU.
- Provides the means for adjusting the electronic signal output from the PMT.

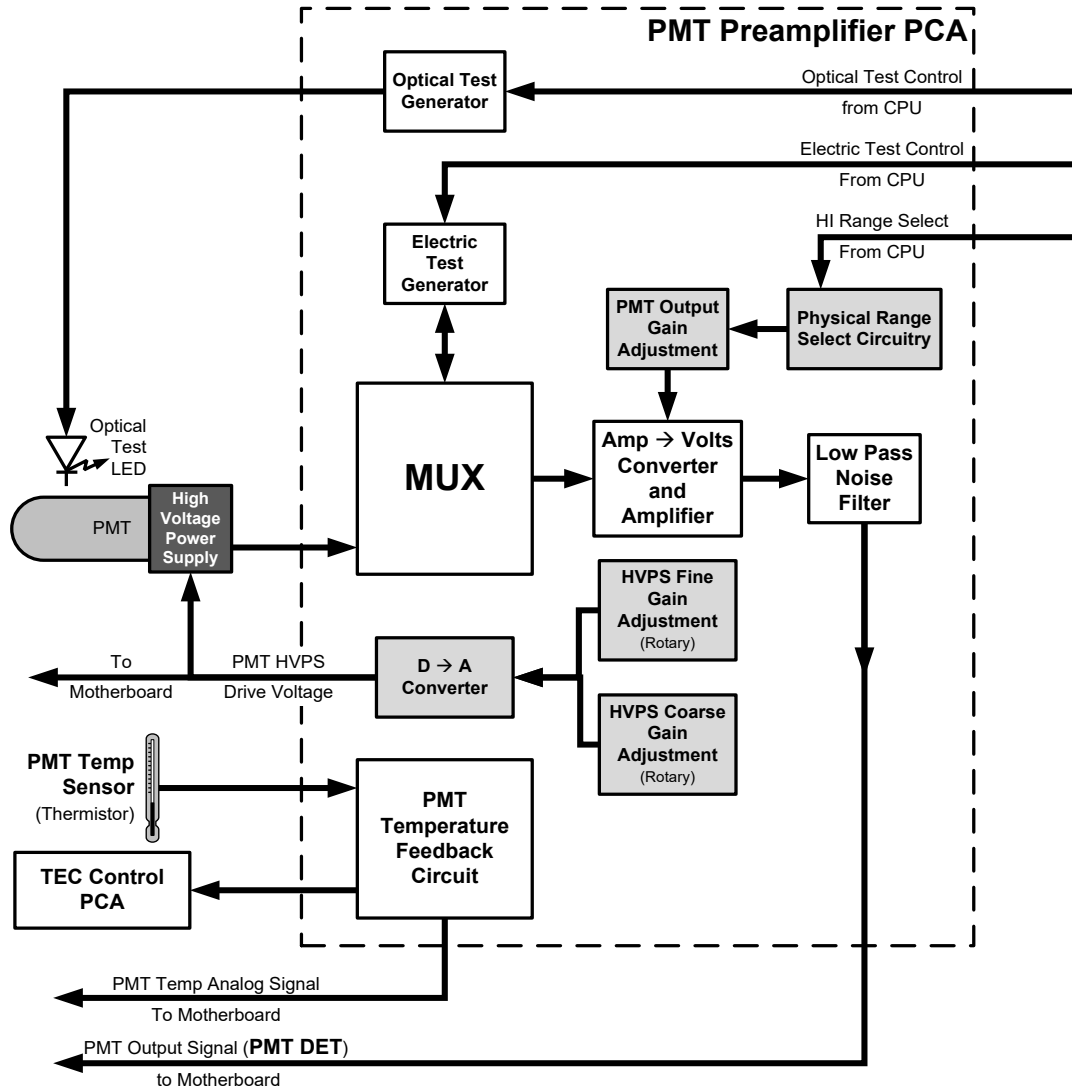

Figure 6-15. PMT Preamp Block Diagram

The PMT preamplifier PCA also operates two different tests used to calibrate and check the performance of the sensor module.

- The electrical test (Utilities>Diagnostics>OE Test, ETest) circuit generates a constant, electronic signal intended to simulate the output of the PMT (after conversion from current to voltage). By bypassing the detector's actual signal, it is possible to test most of the signal handling and conditioning circuitry on the PMT preamplifier board.
- The optical test (Utilities>Diagnostics>OE Test, OTest) feature causes an LED inside the PMT cold block to create a light signal that can be measured with the PMT. If zero air is supplied to the analyzer, the entire measurement capability of the sensor module can be tested including the PMT and the current to voltage conversion circuit on the PMT preamplifier board.

6.5.2. PMT COOLING SYSTEM

The performance of the analyzer’s PMT is significantly affected by temperature. Variations in PMT temperature are directly reflected in the signal output of the PMT. Also the signal to noise ratio of the PMT output is radically influenced by temperature as well. The warmer the PMT is, the noisier its signal becomes until the noise renders the concentration signal useless.

To alleviate this problem, the instrument uses a special cooling system called a thermoelectric cooler (TEC), which is a solid-state active heat pump that transfers heat from a heat absorbing “cool” side to a heat releasing “hot” side via a series of DC powered semiconductor junctions. The effectiveness of the pump at moving heat away from the cold side is reliant on the amount of current flowing through the semiconductor junctions and how well the heat from the hot side can be removed.

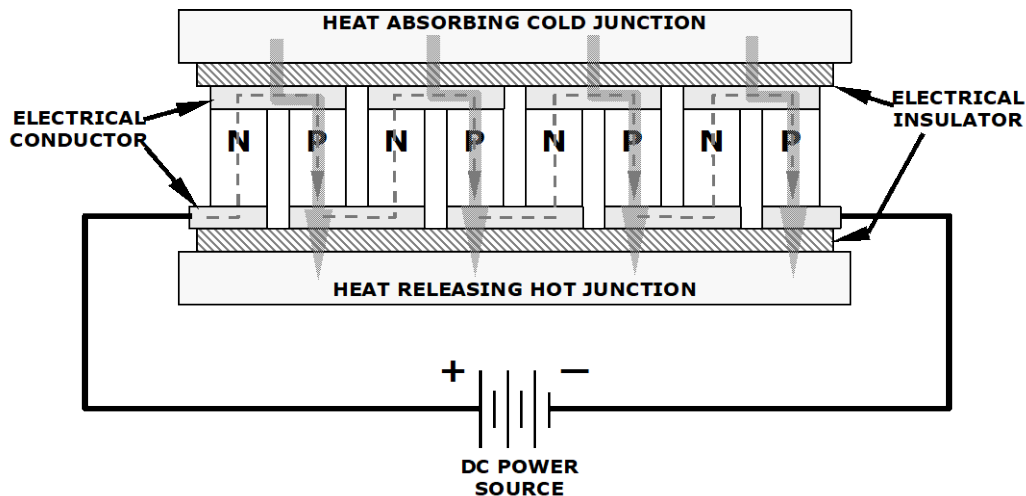

Figure 6-16. Typical Thermo-Electric Cooler

In this case, the current flow is controlled by the TEC Control PCA which adjusts the amount of current applied to the TEC based on the temperature sensed by a thermistor embedded in the PMT’s cold block. The higher the temperature of the PMT, the more current is pumped through the TEC. The “hot” side of the TEC is cooled by a constant flow of ambient air that is directed across a set of heat sinks by a fan.

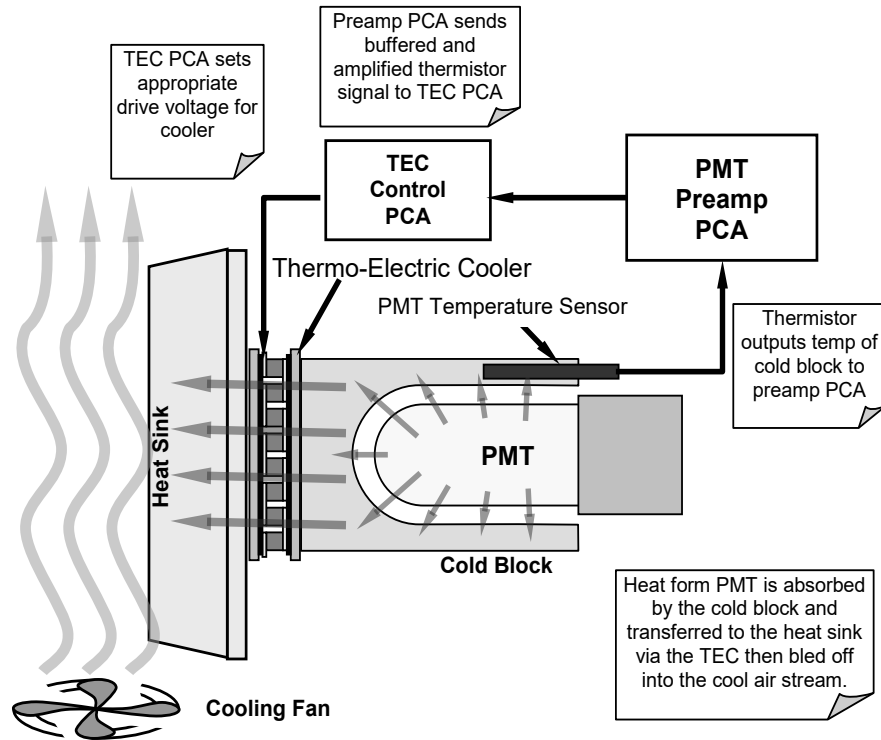

Figure 6-17. PMT Cooling System Block Diagram

The target temperature at which the TEC system keeps the PMT is approximately 8.0°C. Arriving at this temperature may take up to 30 minutes after the instrument is turned on.

The actual temperature of the PMT can be viewed in the Dashboard.

6.5.2.1. TEC CONTROL BOARD

The TEC control PCA is located on the sensor housing assembly, under the slanted shroud, next to the cooling fins and directly above the cooling fan. Using the amplified PMT temperature signal from the PMT preamplifier board (see Section 6.5.1), it sets the drive voltage for the thermoelectric cooler. The warmer the PMT gets, the more current is passed through the TEC causing it to pump more heat to the heat sink.

- A red LED located on the top edge of this circuit board indicates that the control circuit is receiving power.
- Four test points are also located at the top of this assembly.
- For the definitions and acceptable signal levels of these test points see Section 5.7.9.14.

6.6. PNEUMATIC SENSOR BOARD

The flow and pressure sensors of the analyzer are located on a printed circuit assembly just behind the PMT sensor. The signals of this board are supplied to the motherboard for further signal processing. All sensors are linearized in the firmware and can be span calibrated from the front panel.

6.7. POWER SUPPLY/CIRCUIT BREAKER

The analyzer operates on 100 VAC, 115 VAC or 230 VAC power at either 50 Hz or 60Hz. Individual instruments are set up at the factory to accept any combination of these five attributes. A 6.75 amp circuit breaker is built into the ON/OFF switch. In case of a wiring fault or incorrect supply power, the circuit breaker will automatically turn off the analyzer.

- Under normal operation, the analyzer draws about 1.5 A at 115 V and 2.0 A during start-up.



WARNING – ELECTRICAL SHOCK HAZARD

Should the AC power circuit breaker trip, investigate and correct the condition causing this situation before turning the analyzer back on.

Power enters the analyzer through a standard International Electrotechnical Commission (IEC) 320 power receptacle located on the rear panel of the instrument. From there it is routed through the ON/OFF Switch located in the lower right corner of the front panel. AC Line power is stepped down and converted to DC power by two DC power supplies (PS).

- One PS provides +5 VDC (3 A) and ± 15 VDC (1.5/0.5 A) for logic and analog circuitry as well as the power for the O₃ generator.
- The second PS provides +12 VDC (5 A), for the PMT's thermoelectric cooler, fans and as well as the various gas stream valves (both standard and optional).

All AC and DC Voltages, except for the dedicated 24 VDC, are distributed via the relay PCA.

6.7.1. AC POWER CONFIGURATION

The analyzer's digital components will operate with any of the specified power regimes. As long as instrument is connected to 100-120 VAC or 220-240 VAC at either 50 or 60 Hz. Internally, the status LEDs located on the Relay PCA, Motherboard and CPU should turn on as soon as the power is supplied.

However, some of the analyzer's non-digital components, such as the AC-powered heaters for the NO₂ – NO converter or the reaction cell, must be properly configured for the type of power being supplied to the instrument.

Configuration of the power circuits is set using several jumper sets located on the instrument's Relay PCA.

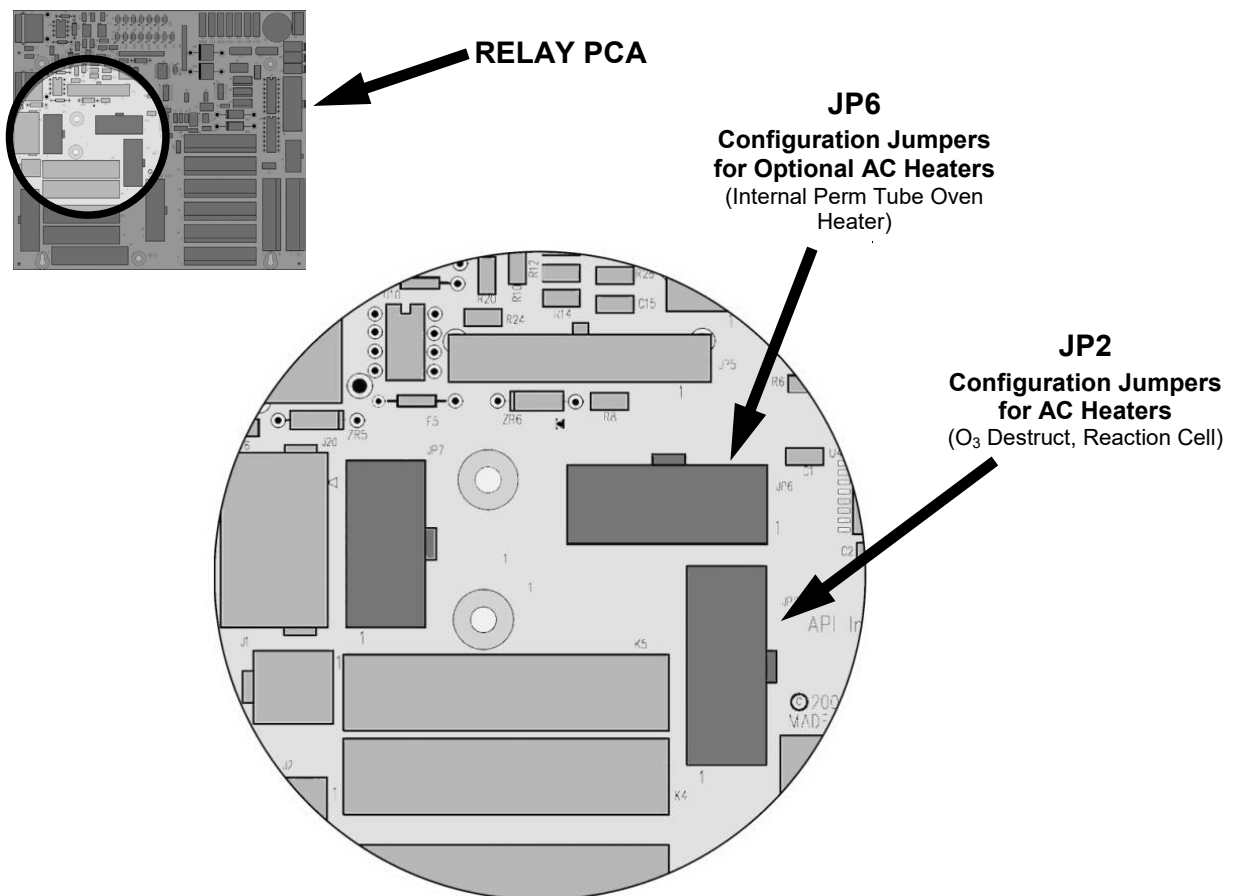

Figure 6-18. Location of AC power Configuration Jumpers

6.7.1.1. AC CONFIGURATION – STANDARD HEATERS (JP2)

Power configuration for the AC the standard heaters is set using Jumper set JP2 (see Figure 6-19 for the location of JP2).

Table 6-3. Power Configuration for Standard AC Heaters (JP2)

LINE VOLTAGE	JUMPER COLOR	HEATER(S)	JUMPER BETWEEN PINS	FUNCTION
110 VAC / 115 VAC 50Hz & 60 Hz	WHITE	Reaction Cell / Sample Chamber Heaters	1 to 8	Common
			2 to 7	Neutral to Load
			4 to 9	Neutral to Load
		Moly Converter Heater	3 to 10	Common
			4 to 9	Neutral to Load
			6 to 11	Neutral to Load
220 VAC / 240 VAC 50Hz & 60 Hz	BLUE	Reaction Cell / Sample Chamber Heaters	1 to 7	Load
		Moly Converter Heater	3 to 9	Load

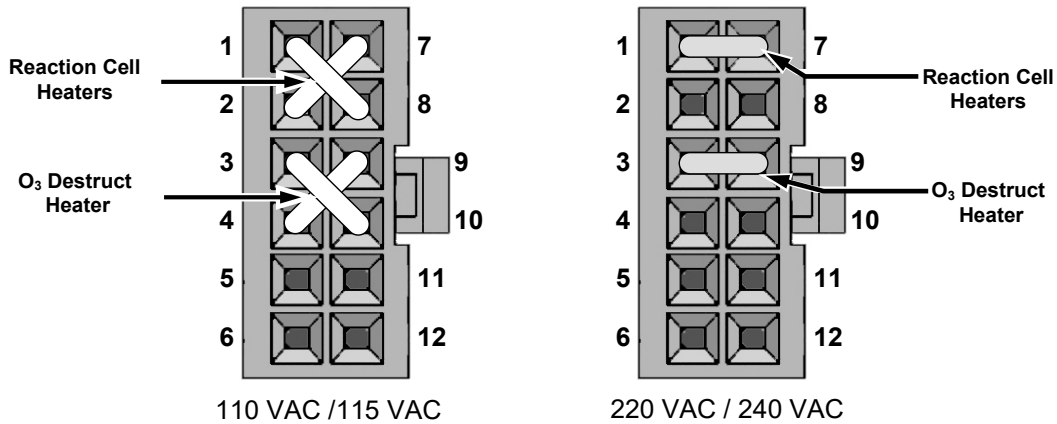

Figure 6-19. Typical Set Up of AC Heater Jumper Set (JP2)

6.8. FRONT PANEL TOUCHSCREEN/DISPLAY INTERFACE

Users can input data and receive information directly through the front panel touchscreen display. The LCD display is controlled directly by the CPU board. The touchscreen is interfaced to the CPU by means of a touchscreen controller that connects to the CPU via the internal USB bus and emulates a computer mouse.

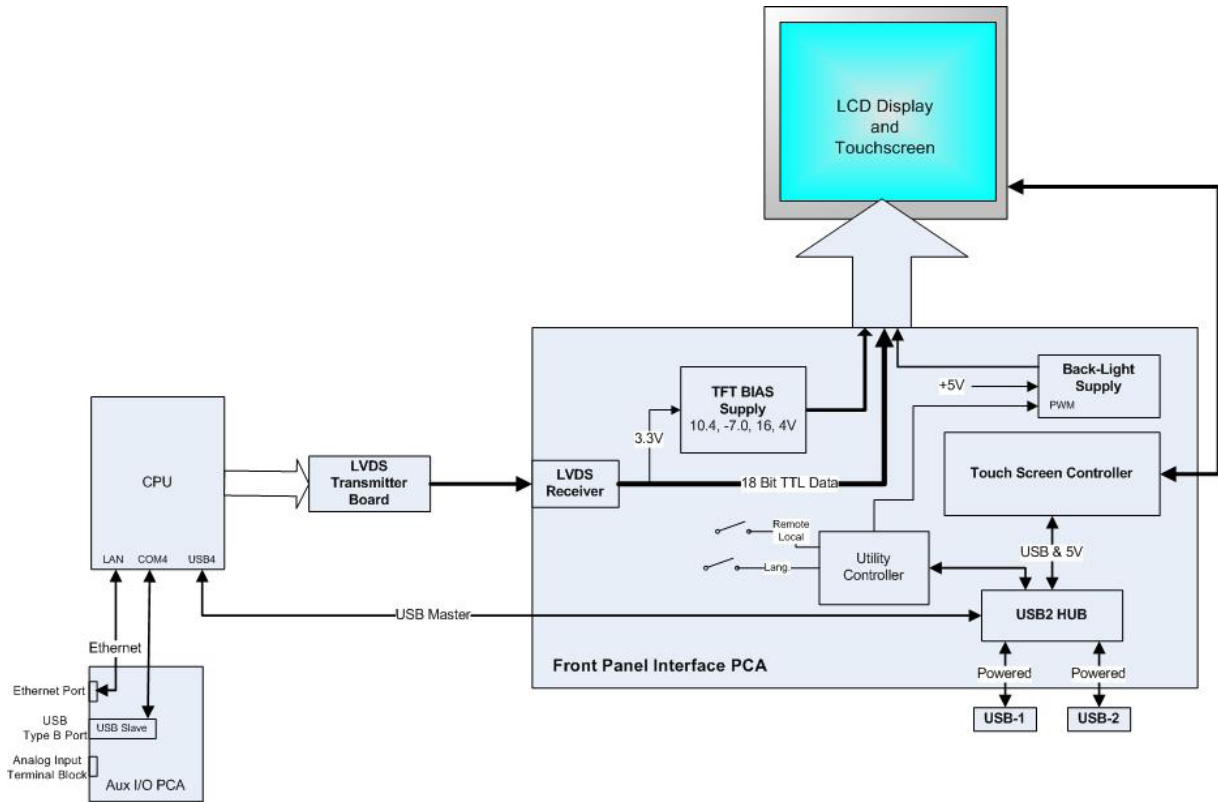

Figure 6-20. Front Panel and Display Interface Block Diagram

6.8.1. LVDS TRANSMITTER BOARD

The LVDS (low voltage differential signaling) transmitter board converts the parallel display bus to a serialized, low voltage, differential signal bus in order to transmit the video signal to the LCD interface PCA.

6.8.2. FRONT PANEL TOUCHSCREEN/DISPLAY INTERFACE PCA

The front panel interface PCA controls the various functions of the display and touchscreen. For driving the display it provides connection between the CPU video controller and the LCD display module. This PCA also contains:

- power supply circuitry for the LCD display module
- USB hub for communications with the touchscreen controller and the two front panel USB device ports
- circuitry for powering the display backlight

6.9. SOFTWARE OPERATION

The analyzer has a high performance, 86-based microcomputer running Windows CE. Inside the WINDOWS CE shell, special software developed by Teledyne API interprets user commands via the various interfaces, performs procedures and tasks, stores data in the CPU's various memory devices and calculates the concentration of the sample gas.

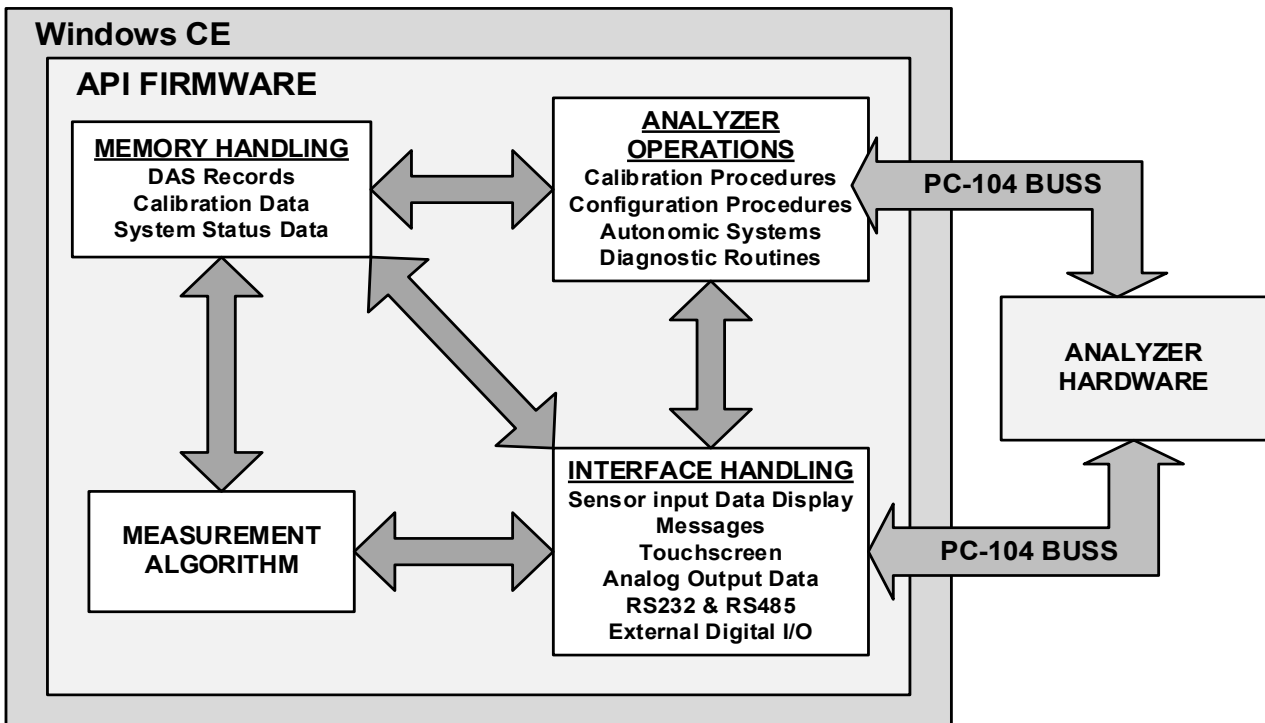

Figure 6-21. Basic Software Operation

6.9.1. ADAPTIVE FILTER

The analyzer software processes sample gas concentration data through a built-in adaptive filter. Unlike other analyzers that average the output signal over a fixed time period, these analyzers average over a defined number of samples. This technique is known as boxcar filtering. During operation, the software may automatically switch between two different filter lengths based on the conditions at hand.

During constant or nearly constant concentrations, the software, by default, computes an average sample value using the long filter. This provides smooth and stable readings and averages out a considerable amount of random noise for an overall less noisy concentration reading.

If the filter detects rapid changes in concentration, the filter reduces its size thus allowing the analyzer to respond more quickly. Two conditions must be simultaneously met to switch to the short filter. First, the instantaneous concentration must differ from the average in the long filter by an absolute amount. Second, the instantaneous concentration must differ from the average in the long filter by at least a set percentage of the average in the long filter.

6.9.2. TEMPERATURE/PRESSURE COMPENSATION (TPC)

The software includes a feature that compensates for some temperature and pressure changes that might affect concentration measurements.

When the TPC feature is enabled (default setting), the analyzer divides the value of the PMT output signal (PMT Signal) by a value called TP_FACTOR, which is calculated using the following four parameters:

- Box Temp: The temperature inside the analyzer's case measured in K. This is typically about 5 K higher than room temperature.
- Rx Cell Temp: The temperature of the reaction cell, measured in K.
- Rx Cell Press: The pressure of the gas in the vacuum manifold, measured in in-Hg-A.
- Sample Press: The pressure of the sample gas before it reaches the reaction cell, measured in in-Hg-A. This measurement is ~1 in-Hg-A lower than atmospheric pressure.

As Rx Cell Temp, Box Temp, Rx Cell Press and Sample Press increase, the value of TP_FACTOR increases and, hence, the PMT Signal value decreases. These adjustments are meant to counter-act changes in the concentrations caused by these parameters.

- The current value of each of these measurements is viewable in the editable Dashboard (see Sections 2.4.2 and 2.5.3).
- The preset gain parameters are set at the factory and may vary from analyzer to analyzer. The TPC feature is enabled or disabled by setting the value of the variable TPC Enable in the Setup>Vars menu. (see Section 2.5.5).

6.9.3. CALIBRATION - SLOPE AND OFFSET

Calibration of the analyzer is performed exclusively in the software. During instrument calibration, (see Section 4) the user enters expected values for zero and span via the front panel touchscreen control and commands the instrument to make readings of calibrated sample gases for both levels.

- The readings taken are adjusted, linearized and compared to the expected values.
- With this information, the software computes values for instrument slope and offset and stores these values in memory for use in calculating the concentrations of the sample gas.

The instrument slope and offset values recorded during the last calibration can be viewed in the Dashboard.

GLOSSARY

TERM	DESCRIPTION/DEFINITION
10BaseT	an Ethernet standard that uses twisted (“T”) pairs of copper wires to transmit at 10 megabits per second (Mbps)
100BaseT	same as 10BaseT except ten times faster (100 Mbps)
APICOM	name of a remote control program offered by Teledyne-API to its customers
ASSY	<i>Assembly</i>
CAS	<i>Code-Activated Switch</i>
CD	<i>Corona Discharge</i> , a frequently luminous discharge, at the surface of a conductor or between two conductors of the same transmission line, accompanied by ionization of the surrounding atmosphere and often by a power loss
CE	<i>Converter Efficiency</i> , the percentage of the total amount that is actually converted (e.g., light energy into electricity; NO ₂ into NO, etc.)
CEM	<i>Continuous Emission Monitoring</i>
Chemical elements that may be included in this document:	
CO ₂	carbon dioxide
C ₃ H ₈	propane
CH ₄	methane
H ₂ O	water vapor
HC	general abbreviation for hydrocarbon
HNO ₃	nitric acid
H ₂ S	hydrogen sulfide
NO	nitric oxide
NO ₂	nitrogen dioxide
NO _x	nitrogen oxides, here defined as the sum of NO and NO ₂
NO _y	nitrogen oxides, often called odd nitrogen: the sum of NO _x plus other compounds such as HNO ₃ (definitions vary widely and may include nitrate (NO ₃), PAN, N ₂ O and other compounds as well)
NH ₃	ammonia
O ₂	molecular oxygen
O ₃	ozone
SO ₂	sulfur dioxide
cm ³	metric abbreviation for <i>cubic centimeter</i> (replaces the obsolete abbreviation “cc”)
CPU	<i>Central Processing Unit</i>
DAC	<i>Digital-to-Analog Converter</i>
DAS	<i>Data Acquisition System</i>
DCE	<i>Data Communication Equipment</i>
DFU	<i>Disposable Filter Unit</i>
DHCP	<i>Dynamic Host Configuration Protocol</i> . A protocol used by LAN or Internet servers to automatically set up the interface protocols between themselves and any other addressable device connected to the network
DOM	<i>Disk On Module</i> , a 44-pin IDE flash drive with up to 128MB storage capacity for instrument’s firmware, configuration settings and data
DOS	<i>Disk Operating System</i>
DRAM	<i>Dynamic Random Access Memory</i>
DR-DOS	<i>Digital Research DOS</i>

TERM	DESCRIPTION/DEFINITION
DTE	<i>Data Terminal Equipment</i>
EEPROM	<i>Electrically Erasable Programmable Read-Only Memory</i> also referred to as a FLASH chip or drive
ESD	<i>Electro-Static Discharge</i>
ETEST	<i>Electrical Test</i>
Ethernet	a standardized (IEEE 802.3) computer networking technology for local area networks (LANs), facilitating communication and sharing resources
FEP	<i>Fluorinated Ethylene Propylene</i> polymer, one of the polymers that Du Pont markets as <i>Teflon</i> [®]
Flash	non-volatile, solid-state memory
FPI	<i>Fabry-Perot Interface</i> : a special light filter typically made of a transparent plate with two reflecting surfaces or two parallel, highly reflective mirrors
GFC	<i>Gas Filter Correlation</i>
I ² C bus	a clocked, bi-directional, serial bus for communication between individual analyzer components
IC	<i>Integrated Circuit</i> , a modern, semi-conductor circuit that can contain many basic components such as resistors, transistors, capacitors, etc., in a miniaturized package used in electronic assemblies
IP	<i>Internet Protocol</i>
IZS	<i>Internal Zero Span</i>
LAN	<i>Local Area Network</i>
LCD	<i>Liquid Crystal Display</i>
LED	<i>Light Emitting Diode</i>
LPM	<i>Liters Per Minute</i>
MFC	<i>Mass Flow Controller</i>
M/R	<i>Measure/Reference</i>
NDIR	<i>Non-Dispersive Infrared</i>
MOLAR MASS	<p>the mass, expressed in grams, of 1 mole of a specific substance. Conversely, one mole is the amount of the substance needed for the molar mass to be the same number in grams as the atomic mass of that substance.</p> <p>EXAMPLE: The atomic weight of Carbon is 12 therefore the molar mass of Carbon is 12 grams. Conversely, one mole of carbon equals the amount of carbon atoms that weighs 12 grams.</p> <p>Atomic weights can be found on any Periodic Table of Elements.</p>
NDIR	<i>Non-Dispersive Infrared</i>
NIST-SRM	<i>National Institute of Standards and Technology - Standard Reference Material</i>
PC	<i>Personal Computer</i>
PCA	<i>Printed Circuit Assembly</i> , the PCB with electronic components, ready to use
PC/AT	<i>Personal Computer / Advanced Technology</i>
PCB	<i>Printed Circuit Board</i> , the bare board without electronic component
PFA	<i>Per-Fluoro-Alkoxy</i> , an inert polymer; one of the polymers that <i>Du Pont</i> markets as <i>Teflon</i> [®]
PLC	<i>Programmable Logic Controller</i> , a device that is used to control instruments based on a logic level signal coming from the analyzer
PLD	<i>Programmable Logic Device</i>
PLL	<i>Phase Lock Loop</i>

TERM	DESCRIPTION/DEFINITION
PMT	<i>Photo Multiplier Tube</i> , a vacuum tube of electrodes that multiply electrons collected and charged to create a detectable current signal
P/N (or PN)	<i>Part Number</i>
PSD	<i>Prevention of Significant Deterioration</i>
PTFE	<i>Poly-Tetra-Fluoro-Ethylene</i> , a very inert polymer material used to handle gases that may react on other surfaces; one of the polymers that <i>Du Pont</i> markets as <i>Teflon</i> [®]
PVC	<i>Poly Vinyl Chloride</i> , a polymer used for downstream tubing
Rdg	Reading
RS-232	specification and standard describing a serial communication method between DTE (Data Terminal Equipment) and DCE (Data Circuit-terminating Equipment) devices, using a maximum cable-length of 50 feet
RS-485	specification and standard describing a binary serial communication method among multiple devices at a data rate faster than RS-232 with a much longer distance between the host and the furthest device
SAROAD	<i>Storage and Retrieval of Aerometric Data</i>
SLAMS	<i>State and Local Air Monitoring Network Plan</i>
SLPM	<i>Standard Liters Per Minute</i> of a gas at standard temperature and pressure
STP	<i>Standard Temperature and Pressure</i>
TCP/IP	<i>Transfer Control Protocol / Internet Protocol</i> , the standard communications protocol for Ethernet devices
TEC	<i>Thermal Electric Cooler</i>
TPC	<i>Temperature/Pressure Compensation</i>
USB	<i>Universal Serial Bus</i> : a standard connection method to establish communication between peripheral devices and a host controller, such as a mouse and/or keyboard and a personal computer or laptop
VARS	<i>Variables</i> , the variable settings of the instrument
V-F	<i>Voltage-to-Frequency</i>
Z/S	<i>Zero / Span</i>



APPENDIX A – MODBUS REGISTERS, T201

ADDRESS	DESCRIPTION
Discrete Inputs	
0	status of Manifold temperature warning
1	status of Converter temperature warning
2	status of Auto zero
3	status of box temperature warning
4	status of PMT_TEMP_WARNING
5	status of RCELL_TEMP_WARNING
6	status of sample flow warning
7	status of Ozone flow warning
8	status of reaction cell pressure warning
9	status of HVPS warning
10	status of system reset warning
11	status of system reset warning
12	status of rear board communication warning
13	status of relay board communication warning
14	status of front panel communication warning
15	status of analog calibration warning
16	status of dynamic zero warning
17	status of dynamic span warning
18	concentration invalid
19	zero calibration active
20	span calibration active
21	multi-point calibration active
22	system is OK
23	status of Ozone generator warning
24	TNx concentration alarm limit 1 exceeded
25	TNx concentration alarm limit 2 exceeded
26	NH3 concentration alarm limit 1 exceeded
27	NH3 concentration alarm limit 2 exceeded
28	NOx concentration alarm limit 1 exceeded
29	NOx concentration alarm limit 2 exceeded
30	NO concentration alarm limit 1 exceeded
31	NO concentration alarm limit 2 exceeded
32	NO2 concentration alarm limit 1 exceeded
33	NO2 concentration alarm limit 2 exceeded
34	TN concentration alarm limit 1 exceeded
35	TN concentration alarm limit 2 exceeded
36	Auto-Cal Seq 1 failed
37	Auto-Cal Seq 2 failed
38	Auto-Cal Seq 3 failed
Coils	
0	Control relay 36
1	Control relay 37
2	Control relay 38
3	Control relay 39
20	Trigger zero calibration of NOx range 1
21	Trigger span calibration of NOx range 1
22	Trigger zero calibration of NOx range 2
23	Trigger span calibration of NOx range 2
24	Trigger zero calibration of TNx range 1
25	Trigger span calibration of TNx range 1



ADDRESS	DESCRIPTION
26	Trigger zero calibration of TNx range 2
27	Trigger span calibration of TNx range 2
Input Registers	
0	PMT Detector Reading in mV
2	TNx slope for range 1
4	TNx slope for range 2
6	NOx slope for range 1
8	NOx slope for range 2
10	NO slope for range 1
12	NO slope for range 2
14	TNx Offset for range 1
16	TNx Offset for range 2
18	NOx Offset for range 1
20	NOx Offset for range 2
22	NO Offset for range 1
24	NO Offset for range 2
26	TNx concentration for range 1 during zero/span calibration
28	TNx concentration for range 2 during zero/span calibration
30	NH3 concentration for range 1 during zero/span calibration
32	NH3 concentration for range 2 during zero/span calibration
34	NOx concentration for range 1 during zero/span calibration
36	NOx concentration for range 2 during zero/span calibration
38	NO concentration for range 1 during zero/span calibration
40	NO concentration for range 2 during zero/span calibration
42	NO2 concentration for range 1 during zero/span calibration
44	NO2 concentration for range 2 during zero/span calibration
46	TNx concentration for range 1
48	TNx concentration for range 2
50	NH3 concentration for range 1
52	NH3 concentration for range 2
54	NOx concentration for range 1
56	NOx concentration for range 2
58	NO concentration for range 1
60	NO concentration for range 2
62	NO2 concentration for range 1
64	NO2 concentration for range 2
66	Auto Zero Offset
68	Ozone flow rate in CCM
70	Reaction cell pressure in In.Hg
72	Reaction cell temperature in degree C
74	Manifold temperature in degree C
76	Orifice block temperature in degree C
78	Converter efficiency factor for range 1
80	Converter efficiency factor for range 2
82	Converter temperature in mV
84	PMT temperature in mV
86	Sample flow in CCM
88	Sample pressure in In. Hg
90	Sample flow in CCM
92	High voltage power supply output in Volts
94	Ground reference in mV
96	4096 mV reference
98	Diagnostic test input 11



T201

ADDRESS	DESCRIPTION
100	Diagnostic test input 13
102	Diagnostic temperature input 6 in degree C
104	TNx concentration for range 1 during zero/span calibration
106	TNx concentration for range 2 during zero/span calibration
108	TNx concentration for range 1
110	TNx concentration for range 2
Holding Registers	
0	TNX span target concentration for range 1
2	NOX span target concentration for range 1
4	NO span target concentration for range 1
6	TNX span target concentration for range 2
8	NOX span target concentration for range 2
10	NO span target concentration for range 2

Appendix B - T201 Interconnect

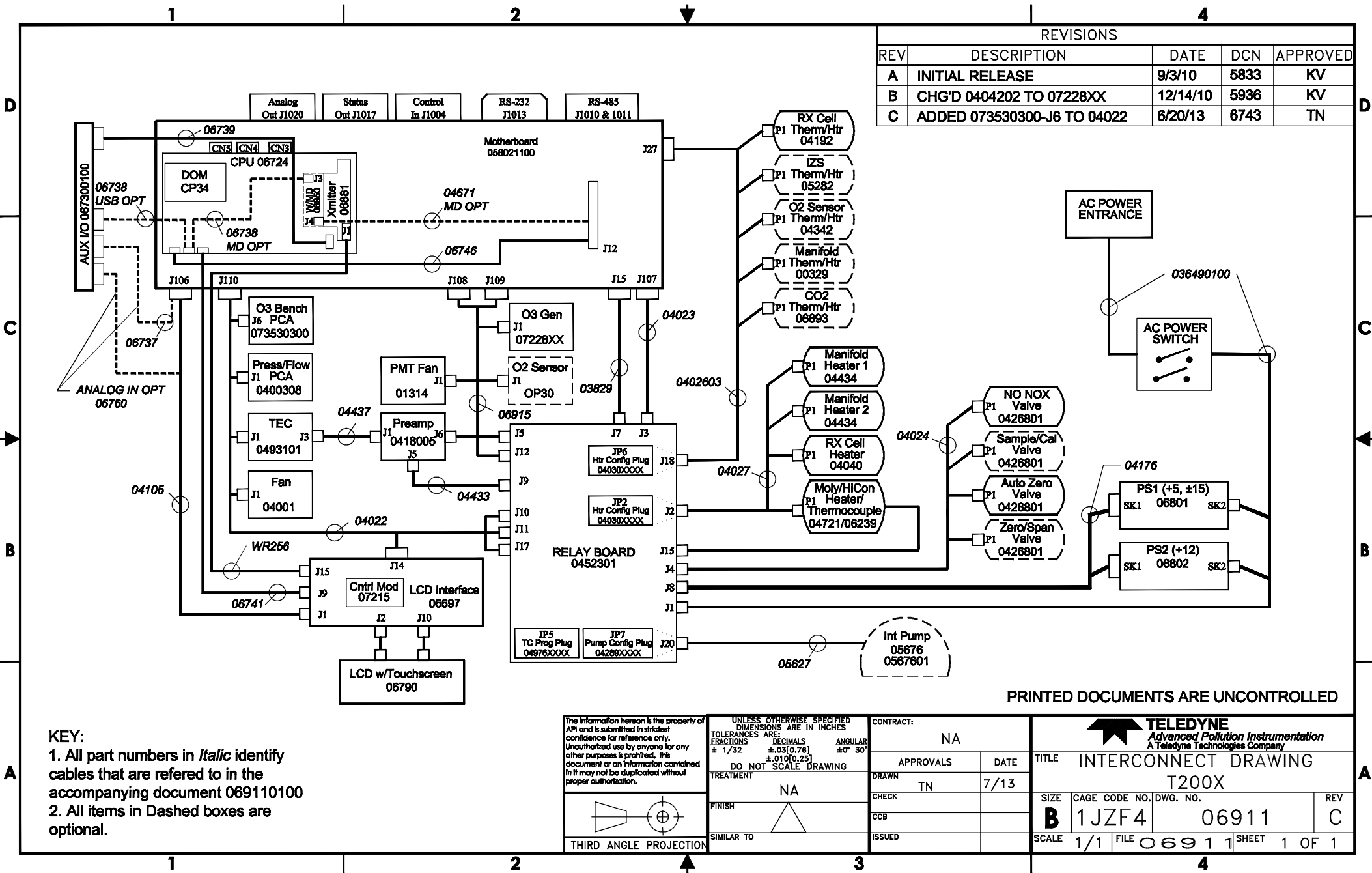

REVISIONS				
REV	DESCRIPTION	DATE	DCN	APPROVED
A	INITIAL RELEASE	9/3/10	5833	KV
B	CHG'D 0404202 TO 07228XX	12/14/10	5936	KV
C	ADDED 073530300-J6 TO 04022	6/20/13	6743	TN

KEY:
 1. All part numbers in *italics* identify cables that are referred to in the accompanying document 069110100
 2. All items in Dashed boxes are optional.

<p>The information herein is the property of API and is submitted in strictest confidence for reference only. Unauthorized use by anyone for any other purposes is prohibited. This document or an information contained in it may not be duplicated without proper authorization.</p> <p>THIRD ANGLE PROJECTION</p>	<p>UNLESS OTHERWISE SPECIFIED DIMENSIONS ARE IN INCHES</p> <p>TOLERANCES ARE: FRACTIONS ± 1/32 DECIMALS ± 0.03 (0.76) ANGULAR ± 0° 30' ± 0.01 (0.25)</p> <p>DO NOT SCALE DRAWING</p> <p>TREATMENT: NA</p> <p>FINISH: </p> <p>SIMILAR TO: </p>	CONTRACT: NA		<p>TELEDYNE Advanced Pollution Instrumentation A Teledyne Technologies Company</p>			
		APPROVALS: _____ DATE: _____		TITLE: INTERCONNECT DRAWING T200X			
		DRAWN: TN	DATE: 7/13	SIZE: B	CAGE CODE NO.: 1JZF4	DWG. NO.: 06911	REV: C
		CHECK: _____	CCB: _____	SCALE: 1/1	FILE: 06911	SHEET: 1 OF 1	ISSUED: _____

PRINTED DOCUMENTS ARE UNCONTROLLED

Appendix B - Model 501 Interconnect

NOTES UNLESS OTHERWISE SPECIFIED:

- PART/ASSEMBLY MATERIALS AND PROCESSES USED DURING ASSEMBLY MUST ADHERE TO TAPI REGULATORY COMPLIANCE SPECIFICATION 083040000.
- ITEMS NOTED IN PARENTHESIS ARE FOR REFERENCE ONLY AND CAN BE CONTROLLED BY OTHER BILLS OF MATERIALS.
- UNLESS OTHERWISE INDICATED, ALL ITEMS IN DASHED BOXES ARE OPTIONS.
- FOR POWER OPTIONS SEE TAPI DOCUMENT 089440000.

REVISIONS				
REV	DESCRIPTION	DATE	DCN	APPROVED
A	INITIAL CREATION	11/19	8252	JTH

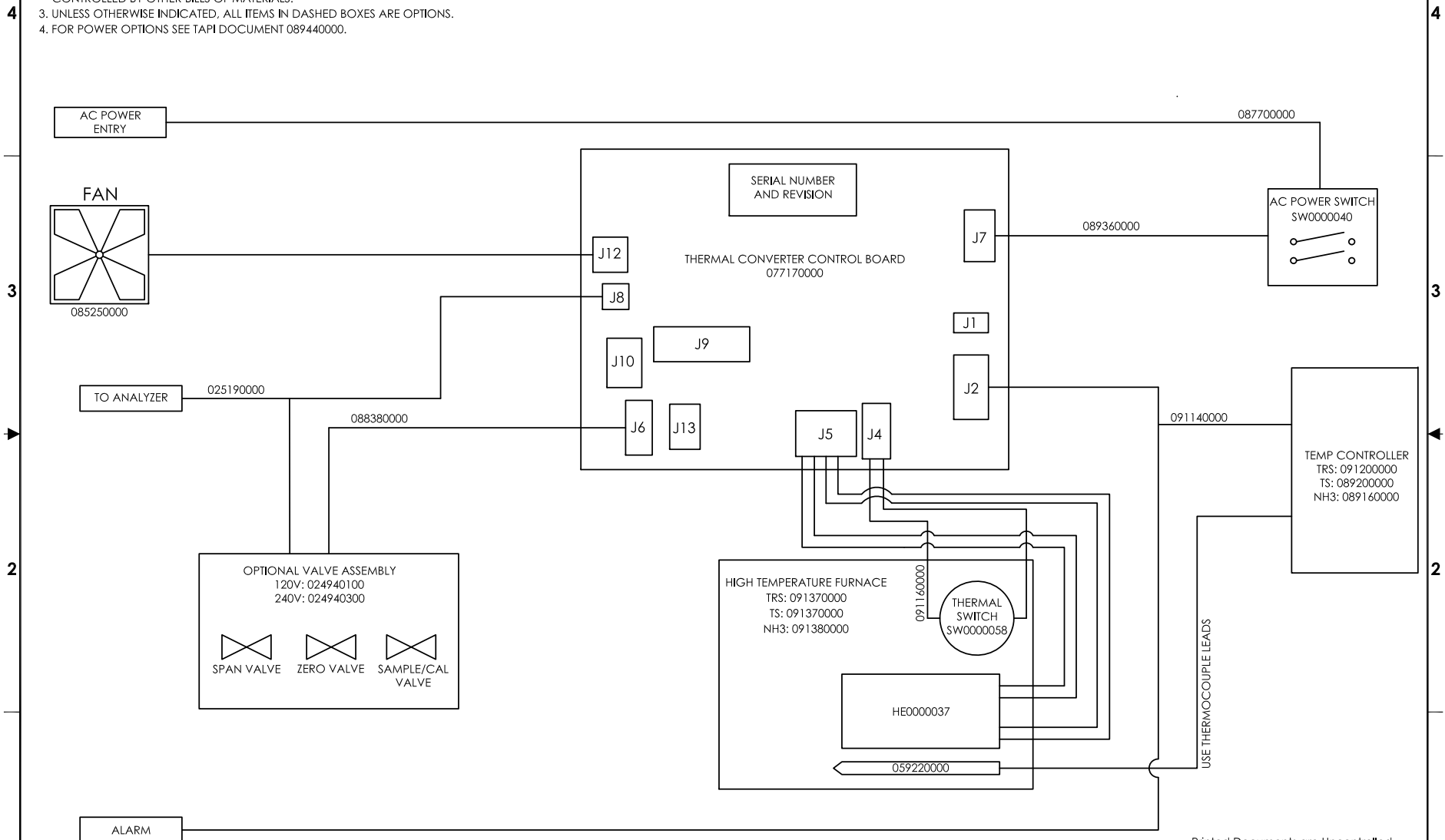

NH3 501 CONVERTER

Printed Documents are Uncontrolled

<p>THIRD ANGLE PROJECTION</p>	<p>The information herein is the property of Teledyne Advanced Pollution Instrumentation and is intended for reference only. Unrestricted use by anyone for any other purposes is prohibited. This document or any information contained in it may not be disclosed without proper authorization.</p> <p>Use and Disclosure of Data: Information contained herein is classified as EAR99 under the U.S. Export Administration regulations. Export, reexport or diversion contrary to U.S. law is prohibited.</p>	<p>UNLESS OTHERWISE SPECIFIED DIMENSIONS ARE IN INCHES</p> <table border="1"> <tr> <th>TOLERANCES ARE:</th> <th>DIGITAL</th> <th>ANGULAR</th> </tr> <tr> <td>FRACTIONS</td> <td>±0.0075</td> <td>±0.5°</td> </tr> <tr> <td>DECIMALS</td> <td>±0.0025</td> <td>±0.25°</td> </tr> </table>		TOLERANCES ARE:	DIGITAL	ANGULAR	FRACTIONS	±0.0075	±0.5°	DECIMALS	±0.0025	±0.25°	<p>CONTRACT: NA</p>		<p>TELEDYNE ADVANCED POLLUTION INSTRUMENTATION Everywhere you look.</p>	
		TOLERANCES ARE:	DIGITAL	ANGULAR												
		FRACTIONS	±0.0075	±0.5°												
		DECIMALS	±0.0025	±0.25°												
<p>DO NOT SCALE DRAWING</p>		<p>APPROVALS</p> <table border="1"> <tr> <th>DATE</th> <th>DATE</th> </tr> <tr> <td>11/19</td> <td></td> </tr> </table>		DATE	DATE	11/19		<p>TITLE: INTERCONNECT, DIAG, 501 CONVERTERS</p>								
DATE	DATE															
11/19																
<p>TREATMENT: NA</p>		<p>DRAWN: JTH</p>		<p>CAGE CODE NO. 09217</p>		<p>REV: A</p>										
<p>FINISH: </p>		<p>CHECK: JTH</p>		<p>SCALE: 1/1</p>		<p>SHEET: 1 OF 2</p>										